

(THIS PAGE INTENTIONALLY LEFT BLANK)

Appendix A: Existing and Proposed Impervious Area Exhibit

(THIS PAGE INTENTIONALLY LEFT BLANK)

Appendix B: Stormwater Quantity Calculations

(THIS PAGE INTENTIONALLY LEFT BLANK)

Peak Flow Hydrologic Analysis

Version: HydroCalc 1.0.2

Input Parameters

Project Name	Link Union Station
Subarea ID	Sub-Area A1 (LID)
Area (ac)	7.38
Flow Path Length (ft)	1000.0
Flow Path Slope (vft/hft)	0.02
85th Percentile Rainfall Depth (in)	1.0
Percent Impervious	1.0
Soil Type	6
Design Storm Frequency	85th percentile storm
Fire Factor	0
LID	True

Output Results

Modeled (85th percentile storm) Rainfall Depth (in)	1.0
Peak Intensity (in/hr)	0.2493
Undeveloped Runoff Coefficient (Cu)	0.1
Developed Runoff Coefficient (Cd)	0.9
Time of Concentration (min)	32.0
Clear Peak Flow Rate (cfs)	1.6561
Burned Peak Flow Rate (cfs)	1.6561
24-Hr Clear Runoff Volume (ac-ft)	0.5489
24-Hr Clear Runoff Volume (cu-ft)	23911.5128

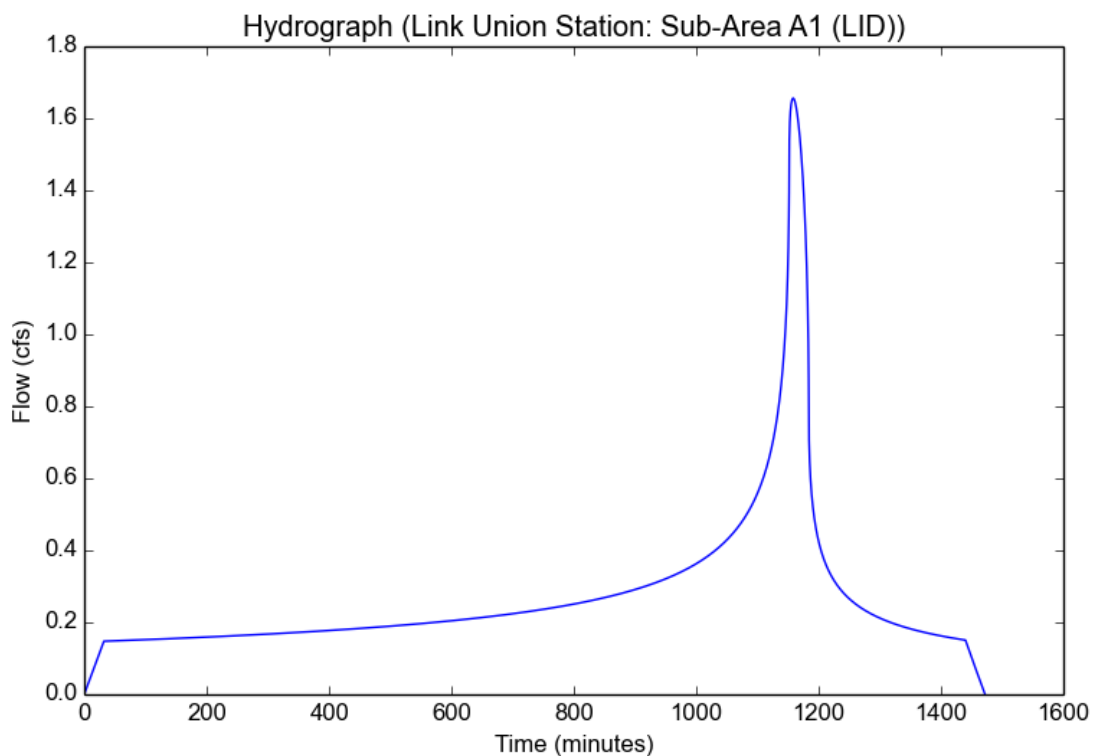

Peak Flow Hydrologic Analysis

Version: HydroCalc 1.0.2

Input Parameters

Project Name	Link Union Station
Subarea ID	Sub-Area A2 (LID)
Area (ac)	5.49
Flow Path Length (ft)	700.0
Flow Path Slope (vft/hft)	0.02
85th Percentile Rainfall Depth (in)	1.0
Percent Impervious	1.0
Soil Type	6
Design Storm Frequency	85th percentile storm
Fire Factor	0
LID	True

Output Results

Modeled (85th percentile storm) Rainfall Depth (in)	1.0
Peak Intensity (in/hr)	0.2749
Undeveloped Runoff Coefficient (Cu)	0.1
Developed Runoff Coefficient (Cd)	0.9
Time of Concentration (min)	26.0
Clear Peak Flow Rate (cfs)	1.3583
Burned Peak Flow Rate (cfs)	1.3583
24-Hr Clear Runoff Volume (ac-ft)	0.4084
24-Hr Clear Runoff Volume (cu-ft)	17787.753

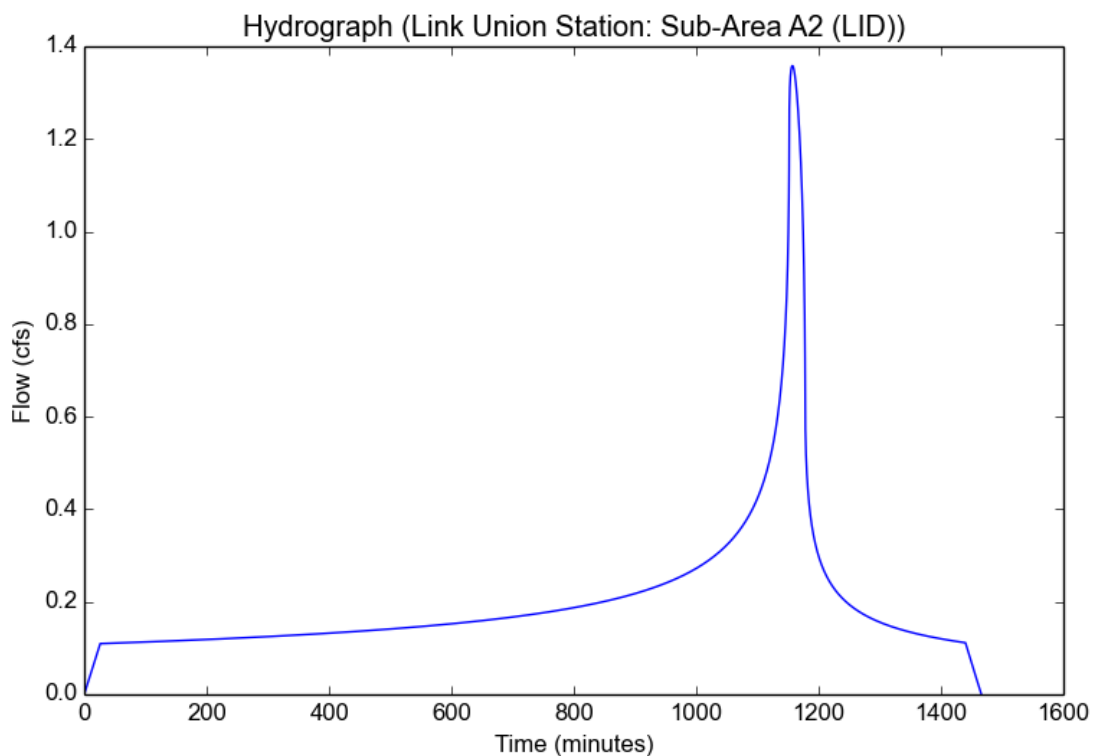

Peak Flow Hydrologic Analysis

Version: HydroCalc 1.0.2

Input Parameters

Project Name	Link Union Station
Subarea ID	Sub-Area A3 (LID)
Area (ac)	6.66
Flow Path Length (ft)	650.0
Flow Path Slope (vft/hft)	0.02
85th Percentile Rainfall Depth (in)	1.0
Percent Impervious	1.0
Soil Type	6
Design Storm Frequency	85th percentile storm
Fire Factor	0
LID	True

Output Results

Modeled (85th percentile storm) Rainfall Depth (in)	1.0
Peak Intensity (in/hr)	0.2854
Undeveloped Runoff Coefficient (Cu)	0.1
Developed Runoff Coefficient (Cd)	0.9
Time of Concentration (min)	24.0
Clear Peak Flow Rate (cfs)	1.7109
Burned Peak Flow Rate (cfs)	1.7109
24-Hr Clear Runoff Volume (ac-ft)	0.4954
24-Hr Clear Runoff Volume (cu-ft)	21578.5579

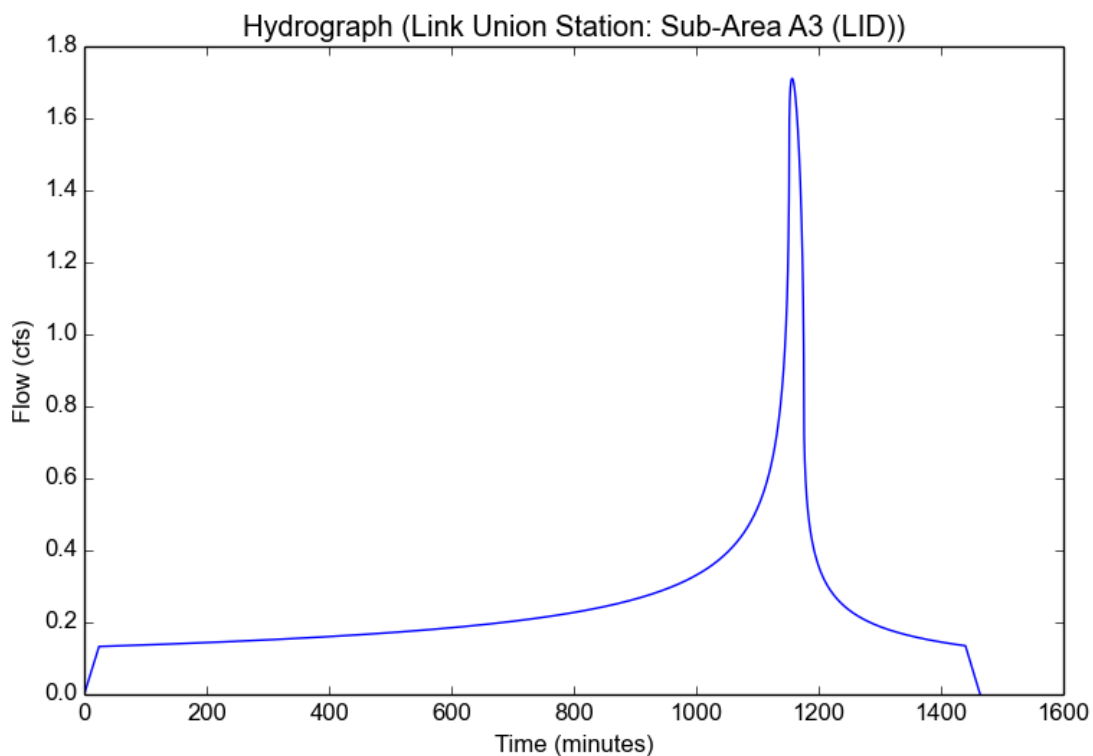

Peak Flow Hydrologic Analysis

Version: HydroCalc 1.0.2

Input Parameters

Project Name	Link Union Station
Subarea ID	Sub-Area A4 (LID)
Area (ac)	0.58
Flow Path Length (ft)	500.0
Flow Path Slope (vft/hft)	0.02
85th Percentile Rainfall Depth (in)	1.0
Percent Impervious	1.0
Soil Type	6
Design Storm Frequency	85th percentile storm
Fire Factor	0
LID	True

Output Results

Modeled (85th percentile storm) Rainfall Depth (in)	1.0
Peak Intensity (in/hr)	0.3039
Undeveloped Runoff Coefficient (Cu)	0.1
Developed Runoff Coefficient (Cd)	0.9
Time of Concentration (min)	21.0
Clear Peak Flow Rate (cfs)	0.1587
Burned Peak Flow Rate (cfs)	0.1587
24-Hr Clear Runoff Volume (ac-ft)	0.0431
24-Hr Clear Runoff Volume (cu-ft)	1879.2105

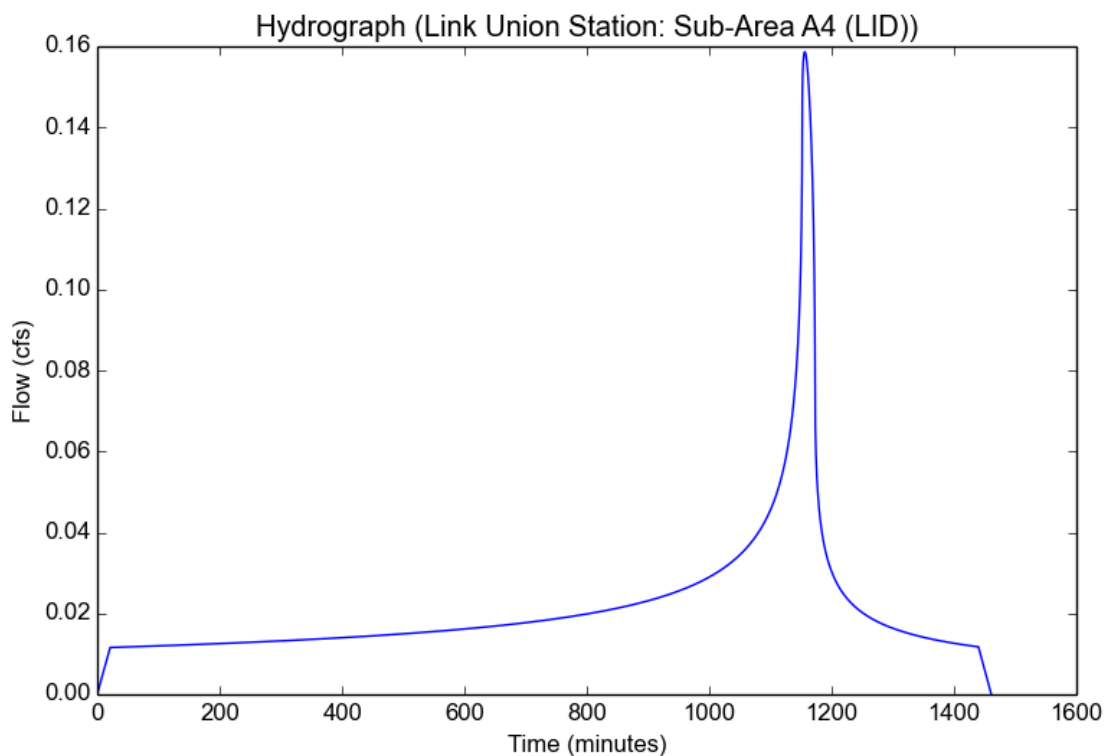

Peak Flow Hydrologic Analysis

Version: HydroCalc 1.0.2

Input Parameters

Project Name	Link Union Station
Subarea ID	Sub-Area A5 (LID)
Area (ac)	2.62
Flow Path Length (ft)	620.0
Flow Path Slope (vft/hft)	0.02
85th Percentile Rainfall Depth (in)	1.0
Percent Impervious	1.0
Soil Type	6
Design Storm Frequency	85th percentile storm
Fire Factor	0
LID	True

Output Results

Modeled (85th percentile storm) Rainfall Depth (in)	1.0
Peak Intensity (in/hr)	0.2854
Undeveloped Runoff Coefficient (Cu)	0.1
Developed Runoff Coefficient (Cd)	0.9
Time of Concentration (min)	24.0
Clear Peak Flow Rate (cfs)	0.6731
Burned Peak Flow Rate (cfs)	0.6731
24-Hr Clear Runoff Volume (ac-ft)	0.1949
24-Hr Clear Runoff Volume (cu-ft)	8488.8621

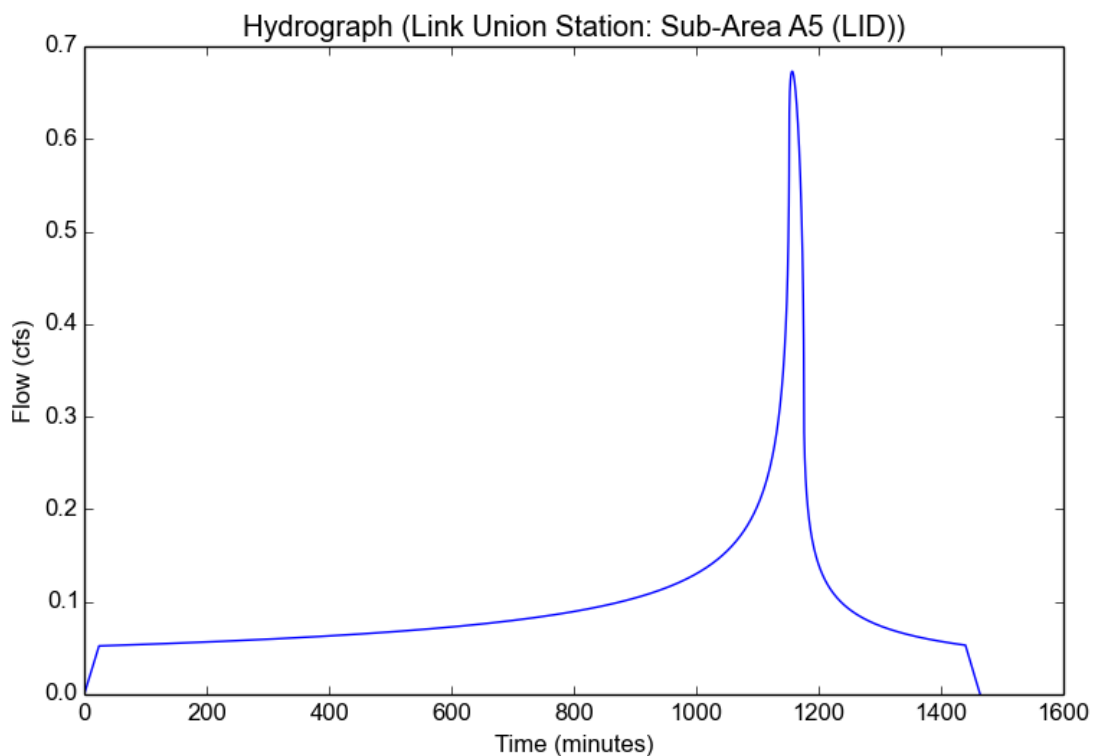

Peak Flow Hydrologic Analysis

Version: HydroCalc 1.0.2

Input Parameters

Project Name	Link Union Station
Subarea ID	Sub-Area A6 (LID)
Area (ac)	0.7
Flow Path Length (ft)	480.0
Flow Path Slope (vft/hft)	0.02
85th Percentile Rainfall Depth (in)	1.0
Percent Impervious	1.0
Soil Type	6
Design Storm Frequency	85th percentile storm
Fire Factor	0
LID	True

Output Results

Modeled (85th percentile storm) Rainfall Depth (in)	1.0
Peak Intensity (in/hr)	0.311
Undeveloped Runoff Coefficient (Cu)	0.1
Developed Runoff Coefficient (Cd)	0.9
Time of Concentration (min)	20.0
Clear Peak Flow Rate (cfs)	0.1959
Burned Peak Flow Rate (cfs)	0.1959
24-Hr Clear Runoff Volume (ac-ft)	0.0521
24-Hr Clear Runoff Volume (cu-ft)	2268.0115

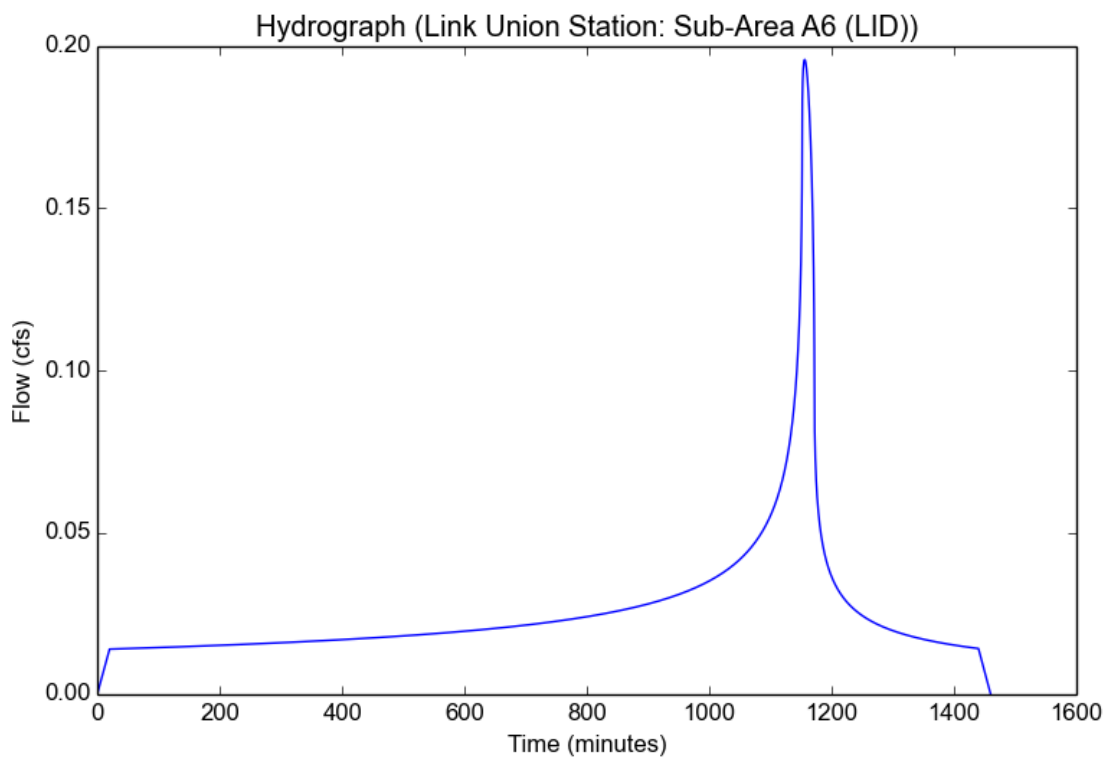

Peak Flow Hydrologic Analysis

Version: HydroCalc 1.0.2

Input Parameters

Project Name	Link Union Station
Subarea ID	Sub-Area A7 (LID)
Area (ac)	0.7
Flow Path Length (ft)	910.0
Flow Path Slope (vft/hft)	0.02
85th Percentile Rainfall Depth (in)	1.0
Percent Impervious	0.91
Soil Type	6
Design Storm Frequency	85th percentile storm
Fire Factor	0
LID	True

Output Results

Modeled (85th percentile storm) Rainfall Depth (in)	1.0
Peak Intensity (in/hr)	0.2493
Undeveloped Runoff Coefficient (Cu)	0.1
Developed Runoff Coefficient (Cd)	0.828
Time of Concentration (min)	32.0
Clear Peak Flow Rate (cfs)	0.1445
Burned Peak Flow Rate (cfs)	0.1445
24-Hr Clear Runoff Volume (ac-ft)	0.0479
24-Hr Clear Runoff Volume (cu-ft)	2086.5873

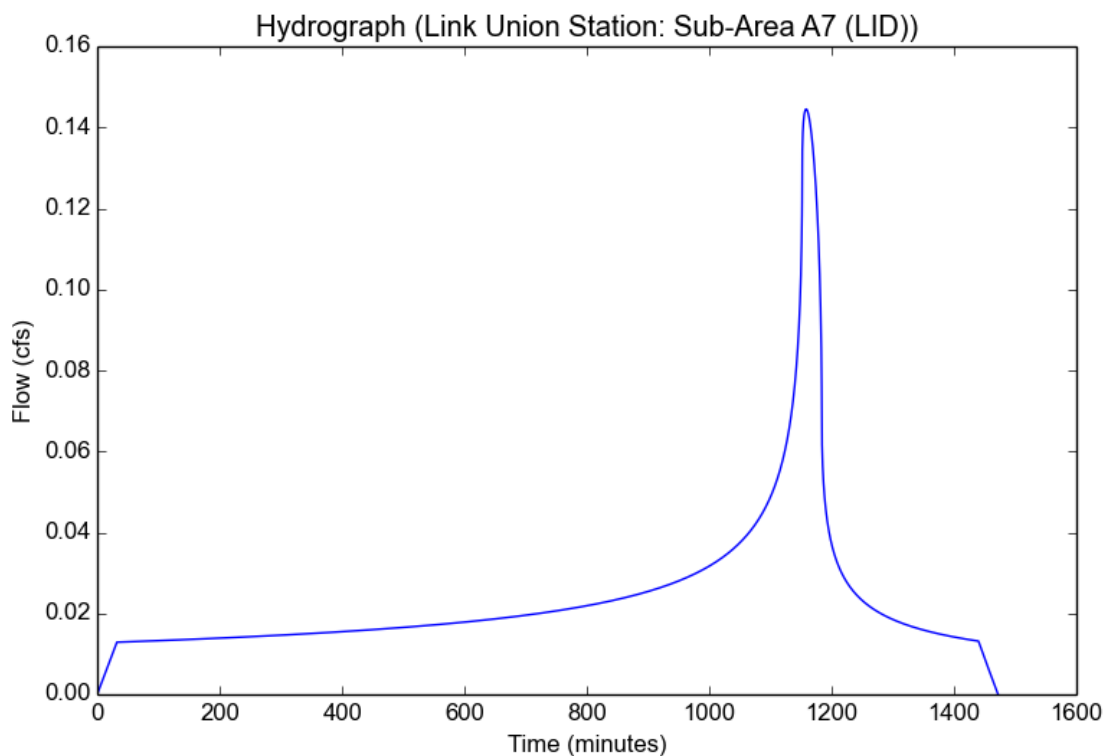

Peak Flow Hydrologic Analysis

Version: HydroCalc 1.0.2

Input Parameters

Project Name	Link Union Station
Subarea ID	Sub-Area A8 (LID)
Area (ac)	0.39
Flow Path Length (ft)	300.0
Flow Path Slope (vft/hft)	0.02
85th Percentile Rainfall Depth (in)	1.0
Percent Impervious	1.0
Soil Type	6
Design Storm Frequency	85th percentile storm
Fire Factor	0
LID	True

Output Results

Modeled (85th percentile storm) Rainfall Depth (in)	1.0
Peak Intensity (in/hr)	0.356
Undeveloped Runoff Coefficient (Cu)	0.1
Developed Runoff Coefficient (Cd)	0.9
Time of Concentration (min)	15.0
Clear Peak Flow Rate (cfs)	0.125
Burned Peak Flow Rate (cfs)	0.125
24-Hr Clear Runoff Volume (ac-ft)	0.029
24-Hr Clear Runoff Volume (cu-ft)	1263.6036

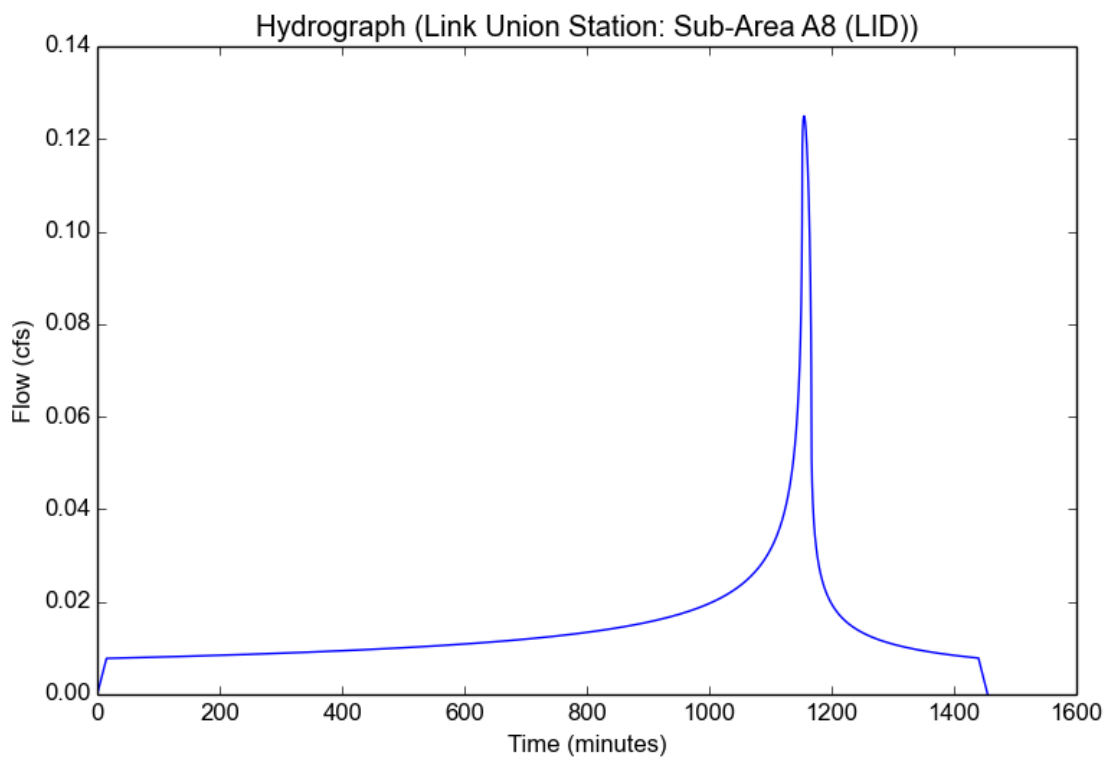

Peak Flow Hydrologic Analysis

Input Parameters

Project Name	LinkUS LID
Subarea ID	Subarea D1
Area (ac)	1.17
Flow Path Length (ft)	390.0
Flow Path Slope (vft/hft)	0.003
85th Percentile Rainfall Depth (in)	1.0
Percent Impervious	0.54
Soil Type	6
Design Storm Frequency	85th percentile storm
Fire Factor	0
LID	True

Output Results

Modeled (85th percentile storm) Rainfall Depth (in)	1.0
Peak Intensity (in/hr)	0.2391
Undeveloped Runoff Coefficient (Cu)	0.1
Developed Runoff Coefficient (Cd)	0.532
Time of Concentration (min)	35.0
Clear Peak Flow Rate (cfs)	0.1488
Burned Peak Flow Rate (cfs)	0.1488
24-Hr Clear Runoff Volume (ac-ft)	0.0514
24-Hr Clear Runoff Volume (cu-ft)	2240.8191

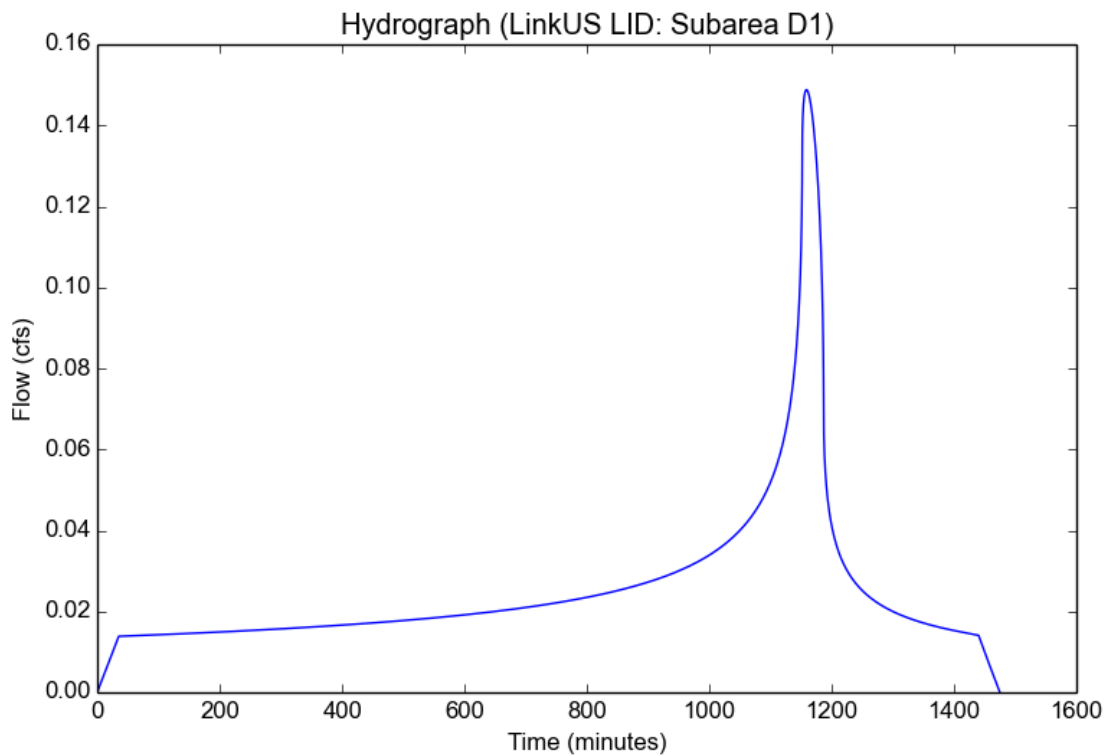

Peak Flow Hydrologic Analysis

Input Parameters

Project Name	LinkUS LID
Subarea ID	Subarea D2
Area (ac)	0.81
Flow Path Length (ft)	125.0
Flow Path Slope (vft/hft)	0.2
85th Percentile Rainfall Depth (in)	1.0
Percent Impervious	0.01
Soil Type	6
Design Storm Frequency	85th percentile storm
Fire Factor	0
LID	True

Output Results

Modeled (85th percentile storm) Rainfall Depth (in)	1.0
Peak Intensity (in/hr)	0.2854
Undeveloped Runoff Coefficient (Cu)	0.1
Developed Runoff Coefficient (Cd)	0.108
Time of Concentration (min)	24.0
Clear Peak Flow Rate (cfs)	0.025
Burned Peak Flow Rate (cfs)	0.025
24-Hr Clear Runoff Volume (ac-ft)	0.0072
24-Hr Clear Runoff Volume (cu-ft)	314.9303

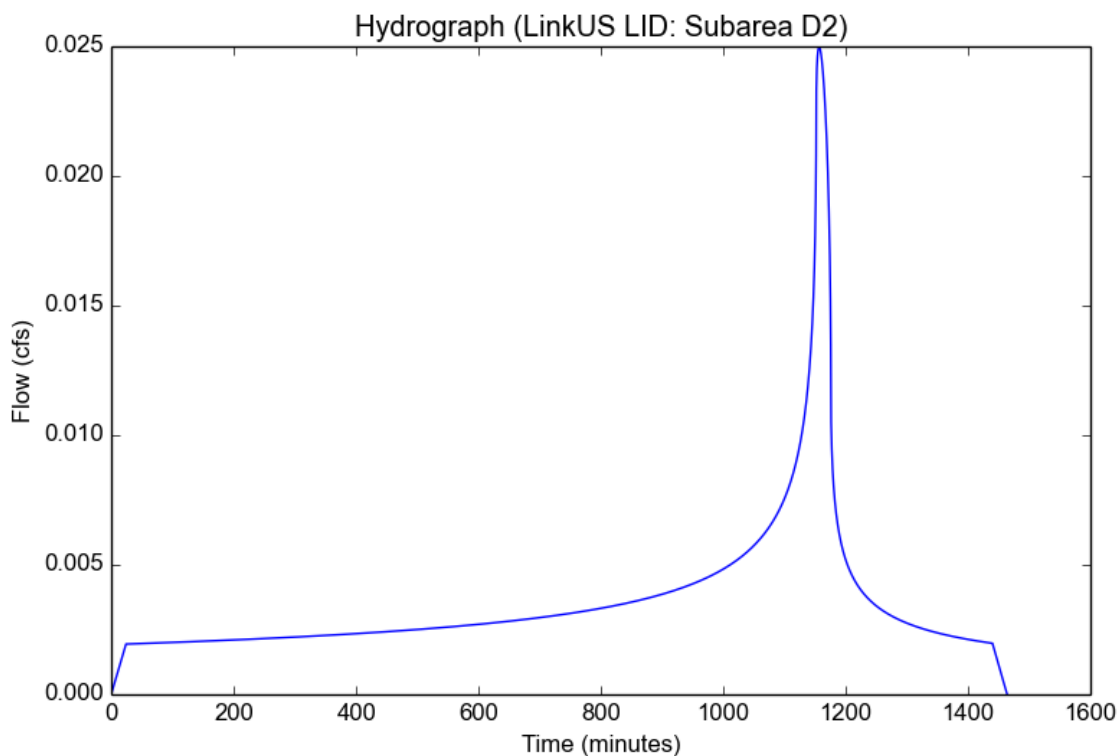

Peak Flow Hydrologic Analysis

Input Parameters

Project Name	LinkUS LID
Subarea ID	Subarea D3
Area (ac)	2.43
Flow Path Length (ft)	388.0
Flow Path Slope (vft/hft)	0.005
85th Percentile Rainfall Depth (in)	1.0
Percent Impervious	0.91
Soil Type	6
Design Storm Frequency	85th percentile storm
Fire Factor	0
LID	True

Output Results

Modeled (85th percentile storm) Rainfall Depth (in)	1.0
Peak Intensity (in/hr)	0.2854
Undeveloped Runoff Coefficient (Cu)	0.1
Developed Runoff Coefficient (Cd)	0.828
Time of Concentration (min)	24.0
Clear Peak Flow Rate (cfs)	0.5743
Burned Peak Flow Rate (cfs)	0.5743
24-Hr Clear Runoff Volume (ac-ft)	0.1663
24-Hr Clear Runoff Volume (cu-ft)	7243.397

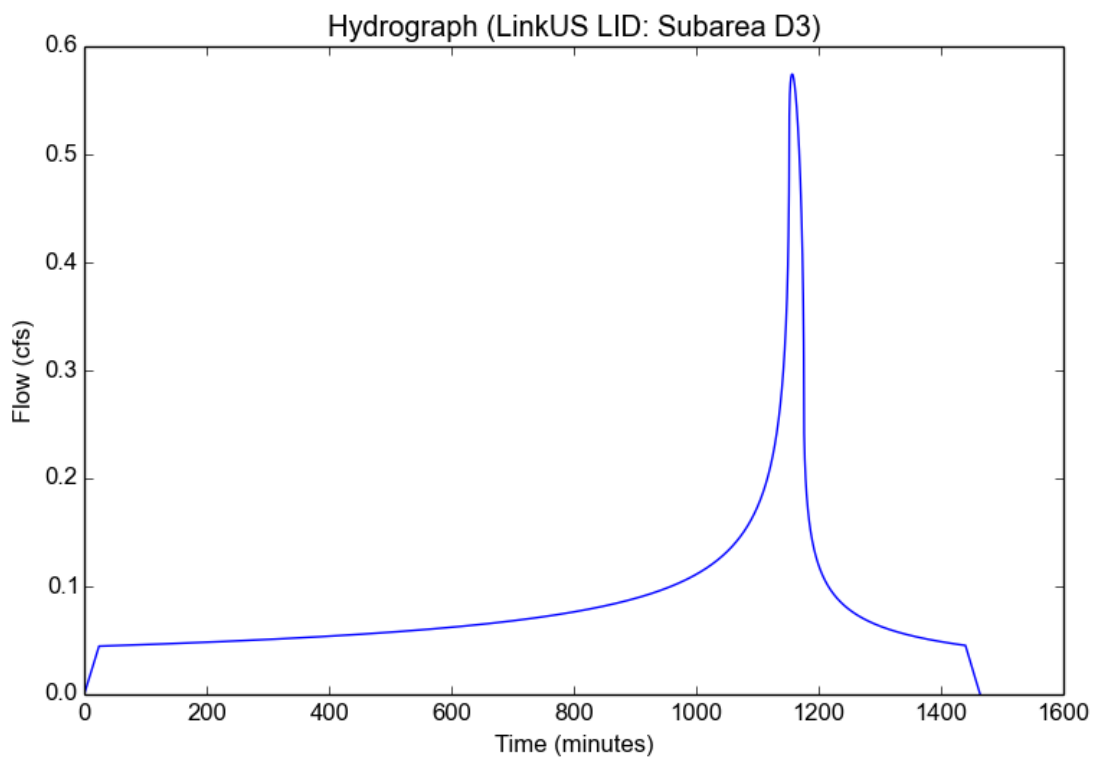

Peak Flow Hydrologic Analysis

Input Parameters

Project Name	LinkUS LID
Subarea ID	Subarea E1
Area (ac)	1.12
Flow Path Length (ft)	295.0
Flow Path Slope (vft/hft)	0.013
85th Percentile Rainfall Depth (in)	1.0
Percent Impervious	0.01
Soil Type	6
Design Storm Frequency	85th percentile storm
Fire Factor	0
LID	True

Output Results

Modeled (85th percentile storm) Rainfall Depth (in)	1.0
Peak Intensity (in/hr)	0.175
Undeveloped Runoff Coefficient (Cu)	0.1
Developed Runoff Coefficient (Cd)	0.108
Time of Concentration (min)	68.0
Clear Peak Flow Rate (cfs)	0.0212
Burned Peak Flow Rate (cfs)	0.0212
24-Hr Clear Runoff Volume (ac-ft)	0.01
24-Hr Clear Runoff Volume (cu-ft)	435.4823

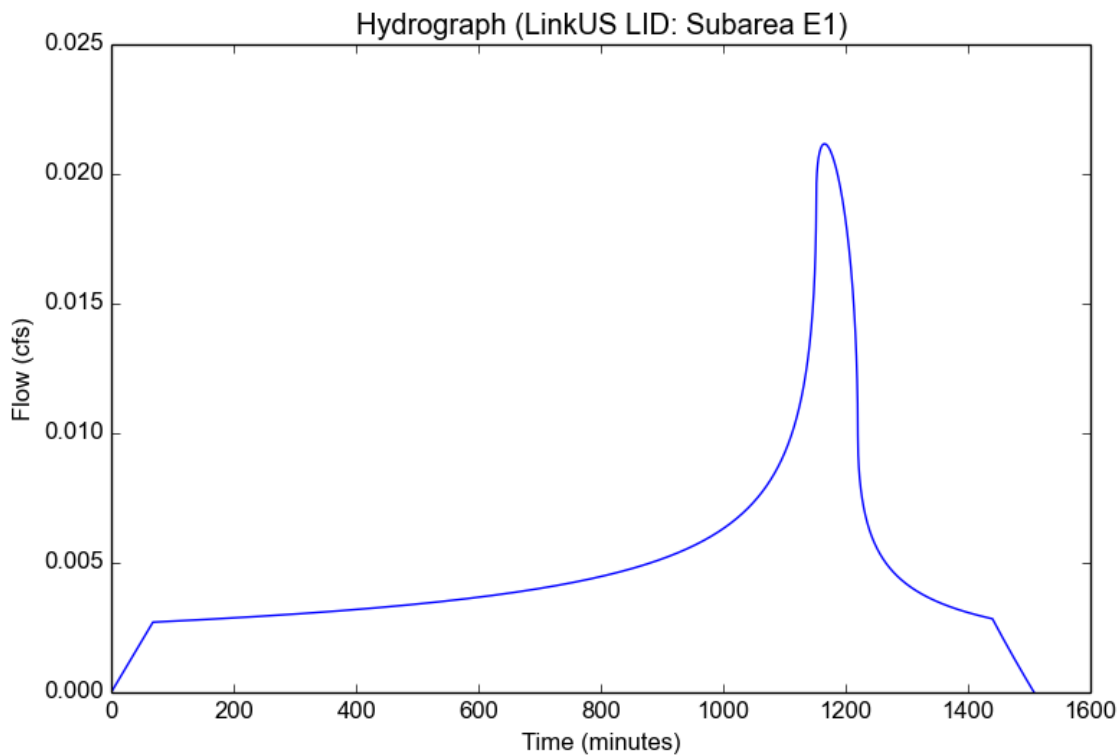

Peak Flow Hydrologic Analysis

Input Parameters

Project Name	LinkUS LID
Subarea ID	Subarea E2
Area (ac)	1.79
Flow Path Length (ft)	439.0
Flow Path Slope (vft/hft)	0.026
85th Percentile Rainfall Depth (in)	1.0
Percent Impervious	0.62
Soil Type	6
Design Storm Frequency	85th percentile storm
Fire Factor	0
LID	True

Output Results

Modeled (85th percentile storm) Rainfall Depth (in)	1.0
Peak Intensity (in/hr)	0.2854
Undeveloped Runoff Coefficient (Cu)	0.1
Developed Runoff Coefficient (Cd)	0.596
Time of Concentration (min)	24.0
Clear Peak Flow Rate (cfs)	0.3045
Burned Peak Flow Rate (cfs)	0.3045
24-Hr Clear Runoff Volume (ac-ft)	0.0882
24-Hr Clear Runoff Volume (cu-ft)	3840.6521

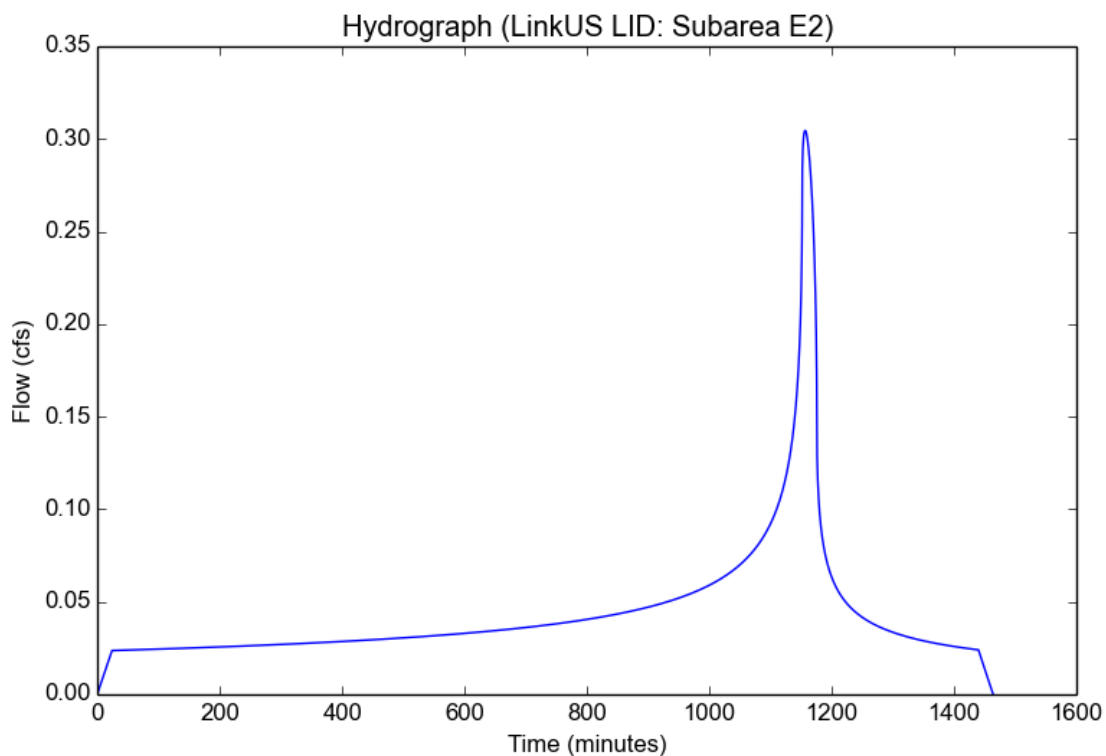

Peak Flow Hydrologic Analysis

Input Parameters

Project Name	LinkUS LID
Subarea ID	Subarea F1
Area (ac)	1.49
Flow Path Length (ft)	140.0
Flow Path Slope (vft/hft)	0.038
85th Percentile Rainfall Depth (in)	1.0
Percent Impervious	0.47
Soil Type	6
Design Storm Frequency	85th percentile storm
Fire Factor	0
LID	True

Output Results

Modeled (85th percentile storm) Rainfall Depth (in)	1.0
Peak Intensity (in/hr)	0.3954
Undeveloped Runoff Coefficient (Cu)	0.1436
Developed Runoff Coefficient (Cd)	0.4991
Time of Concentration (min)	12.0
Clear Peak Flow Rate (cfs)	0.294
Burned Peak Flow Rate (cfs)	0.294
24-Hr Clear Runoff Volume (ac-ft)	0.0587
24-Hr Clear Runoff Volume (cu-ft)	2556.8011

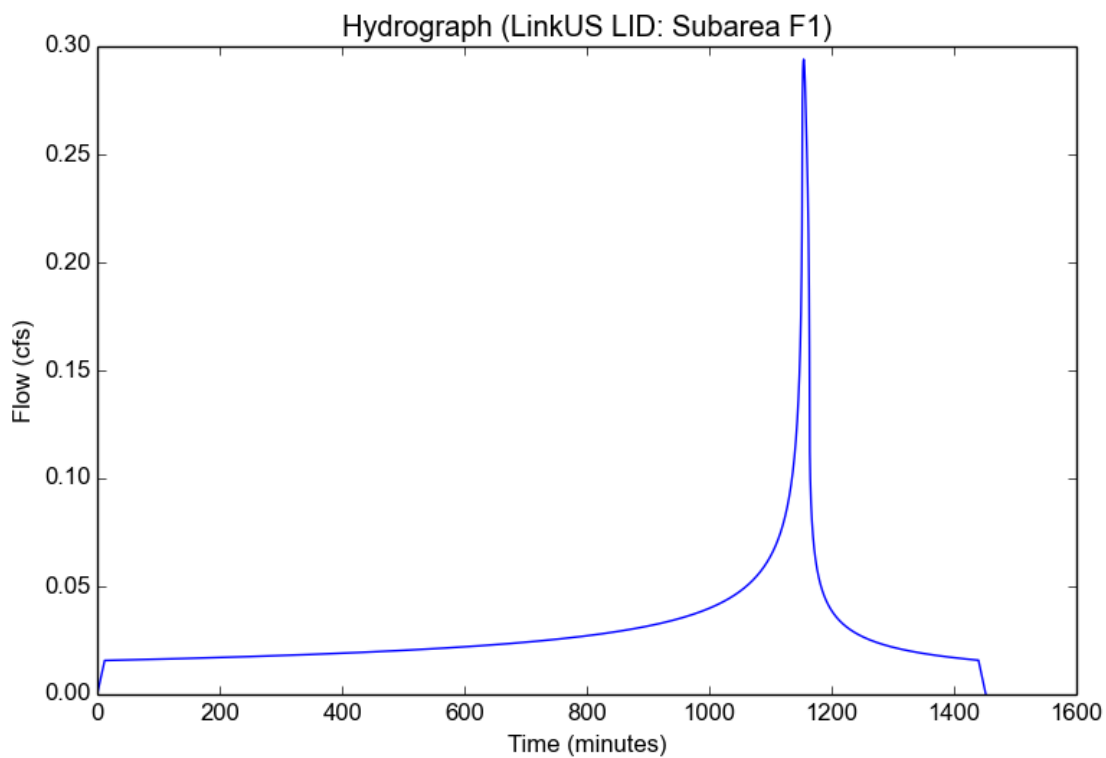

Peak Flow Hydrologic Analysis

Input Parameters

Project Name	LinkUS LID
Subarea ID	Subarea F2
Area (ac)	1.07
Flow Path Length (ft)	214.0
Flow Path Slope (vft/hft)	0.006
85th Percentile Rainfall Depth (in)	1.0
Percent Impervious	0.91
Soil Type	6
Design Storm Frequency	85th percentile storm
Fire Factor	0
LID	True

Output Results

Modeled (85th percentile storm) Rainfall Depth (in)	1.0
Peak Intensity (in/hr)	0.3454
Undeveloped Runoff Coefficient (Cu)	0.1
Developed Runoff Coefficient (Cd)	0.828
Time of Concentration (min)	16.0
Clear Peak Flow Rate (cfs)	0.306
Burned Peak Flow Rate (cfs)	0.306
24-Hr Clear Runoff Volume (ac-ft)	0.0732
24-Hr Clear Runoff Volume (cu-ft)	3189.4663

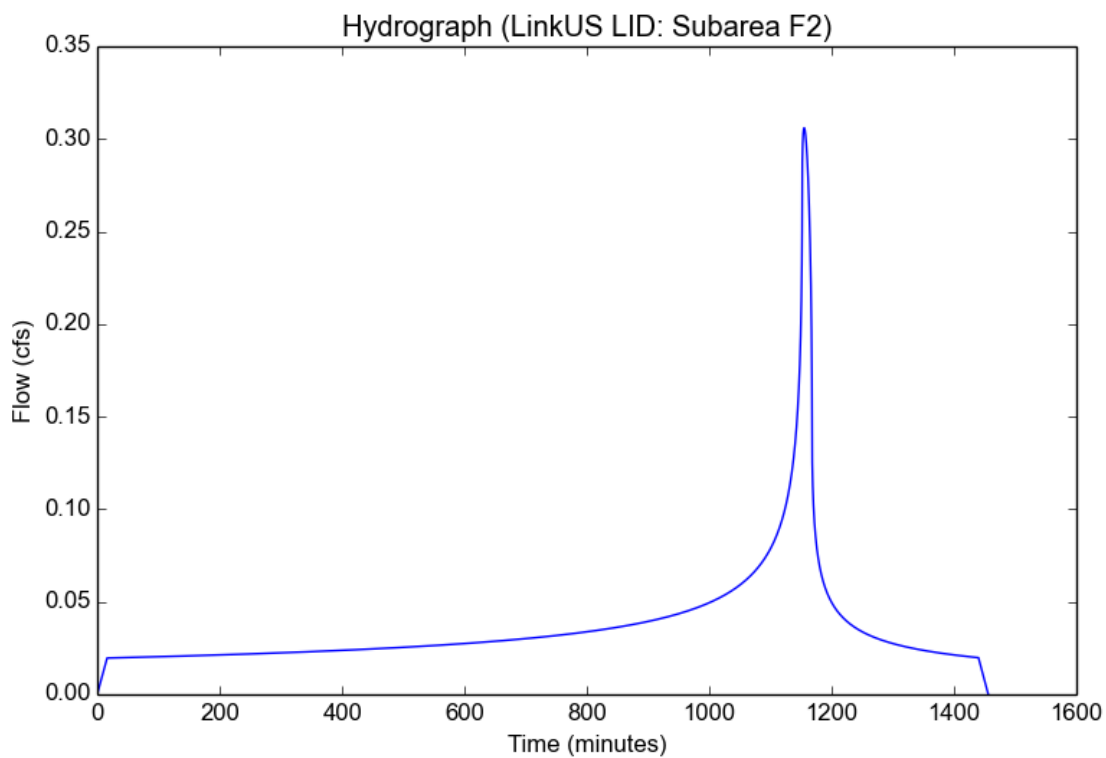

Peak Flow Hydrologic Analysis

Input Parameters

Project Name	LinkUS LID
Subarea ID	Subarea G1
Area (ac)	0.65
Flow Path Length (ft)	111.0
Flow Path Slope (vft/hft)	0.029
85th Percentile Rainfall Depth (in)	1.0
Percent Impervious	0.12
Soil Type	6
Design Storm Frequency	85th percentile storm
Fire Factor	0
LID	True

Output Results

Modeled (85th percentile storm) Rainfall Depth (in)	1.0
Peak Intensity (in/hr)	0.3039
Undeveloped Runoff Coefficient (Cu)	0.1
Developed Runoff Coefficient (Cd)	0.196
Time of Concentration (min)	21.0
Clear Peak Flow Rate (cfs)	0.0387
Burned Peak Flow Rate (cfs)	0.0387
24-Hr Clear Runoff Volume (ac-ft)	0.0105
24-Hr Clear Runoff Volume (cu-ft)	458.6426

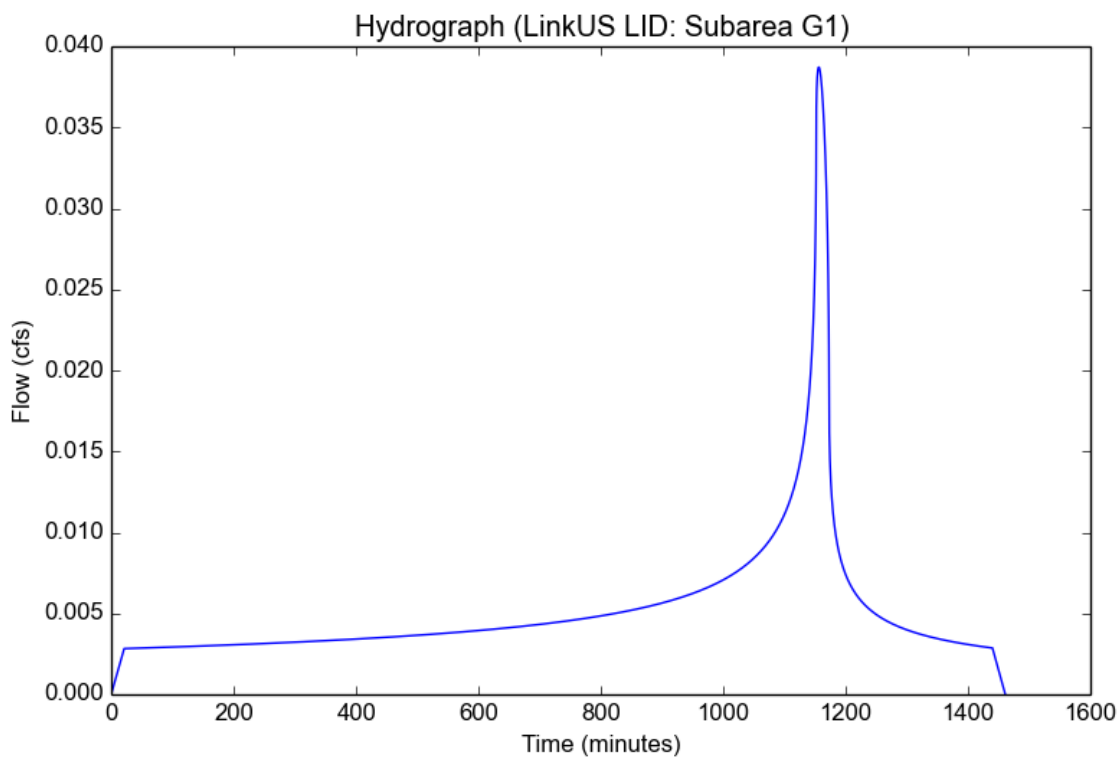

Peak Flow Hydrologic Analysis

Input Parameters

Project Name	LinkUS LID
Subarea ID	Subarea G2
Area (ac)	1.95
Flow Path Length (ft)	140.0
Flow Path Slope (vft/hft)	0.152
85th Percentile Rainfall Depth (in)	1.0
Percent Impervious	0.01
Soil Type	6
Design Storm Frequency	85th percentile storm
Fire Factor	0
LID	True

Output Results

Modeled (85th percentile storm) Rainfall Depth (in)	1.0
Peak Intensity (in/hr)	0.2701
Undeveloped Runoff Coefficient (Cu)	0.1
Developed Runoff Coefficient (Cd)	0.108
Time of Concentration (min)	27.0
Clear Peak Flow Rate (cfs)	0.0569
Burned Peak Flow Rate (cfs)	0.0569
24-Hr Clear Runoff Volume (ac-ft)	0.0174
24-Hr Clear Runoff Volume (cu-ft)	758.167

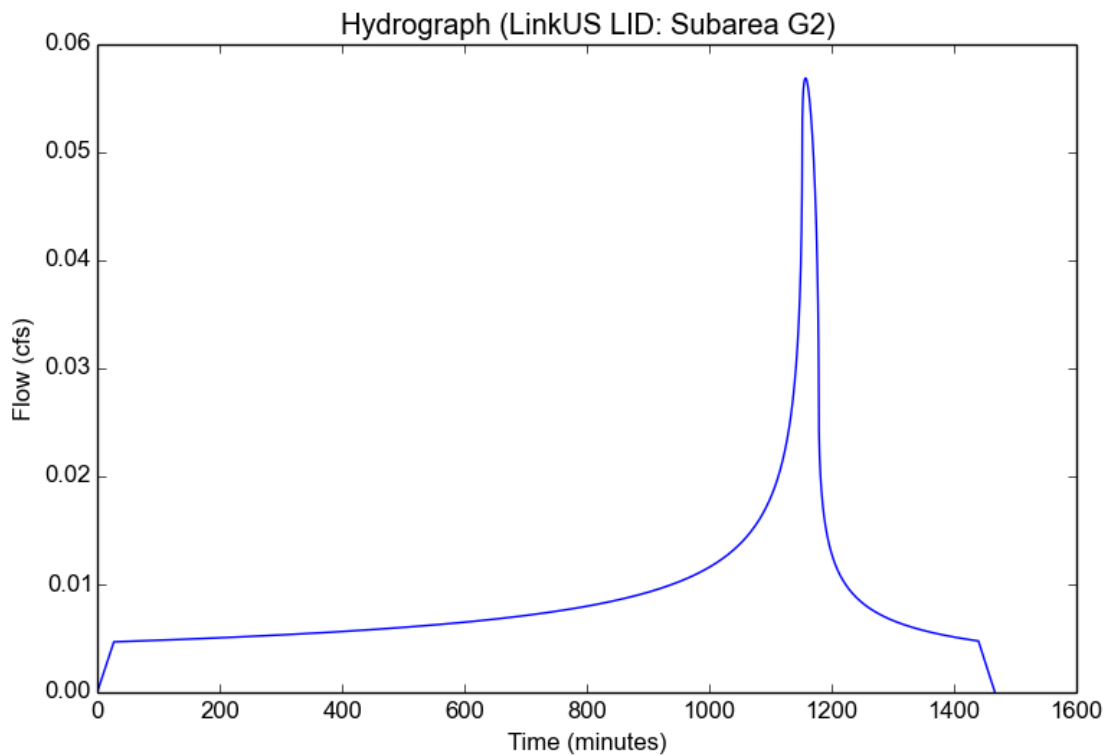

Peak Flow Hydrologic Analysis

Input Parameters

Project Name	LinkUS LID
Subarea ID	Subarea G3
Area (ac)	0.94
Flow Path Length (ft)	383.0
Flow Path Slope (vft/hft)	0.005
85th Percentile Rainfall Depth (in)	1.0
Percent Impervious	0.91
Soil Type	6
Design Storm Frequency	85th percentile storm
Fire Factor	0
LID	True

Output Results

Modeled (85th percentile storm) Rainfall Depth (in)	1.0
Peak Intensity (in/hr)	0.2854
Undeveloped Runoff Coefficient (Cu)	0.1
Developed Runoff Coefficient (Cd)	0.828
Time of Concentration (min)	24.0
Clear Peak Flow Rate (cfs)	0.2222
Burned Peak Flow Rate (cfs)	0.2222
24-Hr Clear Runoff Volume (ac-ft)	0.0643
24-Hr Clear Runoff Volume (cu-ft)	2801.9725

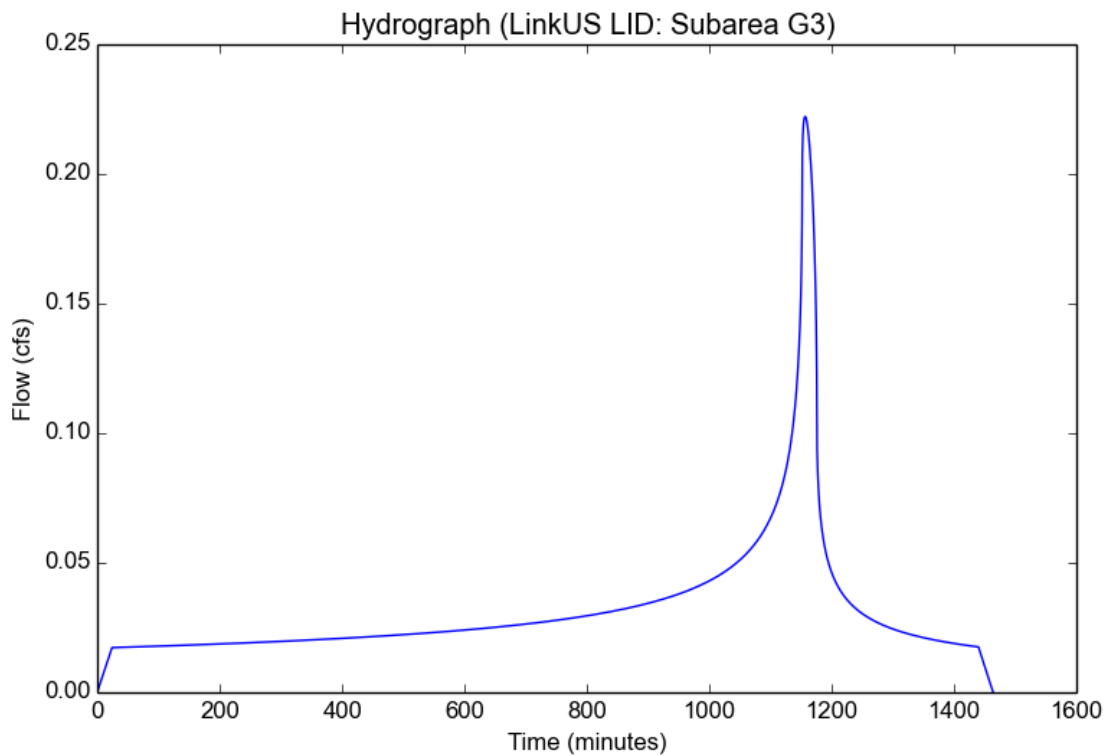

Peak Flow Hydrologic Analysis

Input Parameters

Project Name	LinkUS LID
Subarea ID	Subarea G4
Area (ac)	3.43
Flow Path Length (ft)	1362.0
Flow Path Slope (vft/hft)	0.007
85th Percentile Rainfall Depth (in)	1.0
Percent Impervious	0.15
Soil Type	6
Design Storm Frequency	85th percentile storm
Fire Factor	0
LID	True

Output Results

Modeled (85th percentile storm) Rainfall Depth (in)	1.0
Peak Intensity (in/hr)	0.1319
Undeveloped Runoff Coefficient (Cu)	0.1
Developed Runoff Coefficient (Cd)	0.22
Time of Concentration (min)	124.0
Clear Peak Flow Rate (cfs)	0.0995
Burned Peak Flow Rate (cfs)	0.0995
24-Hr Clear Runoff Volume (ac-ft)	0.0624
24-Hr Clear Runoff Volume (cu-ft)	2717.1276

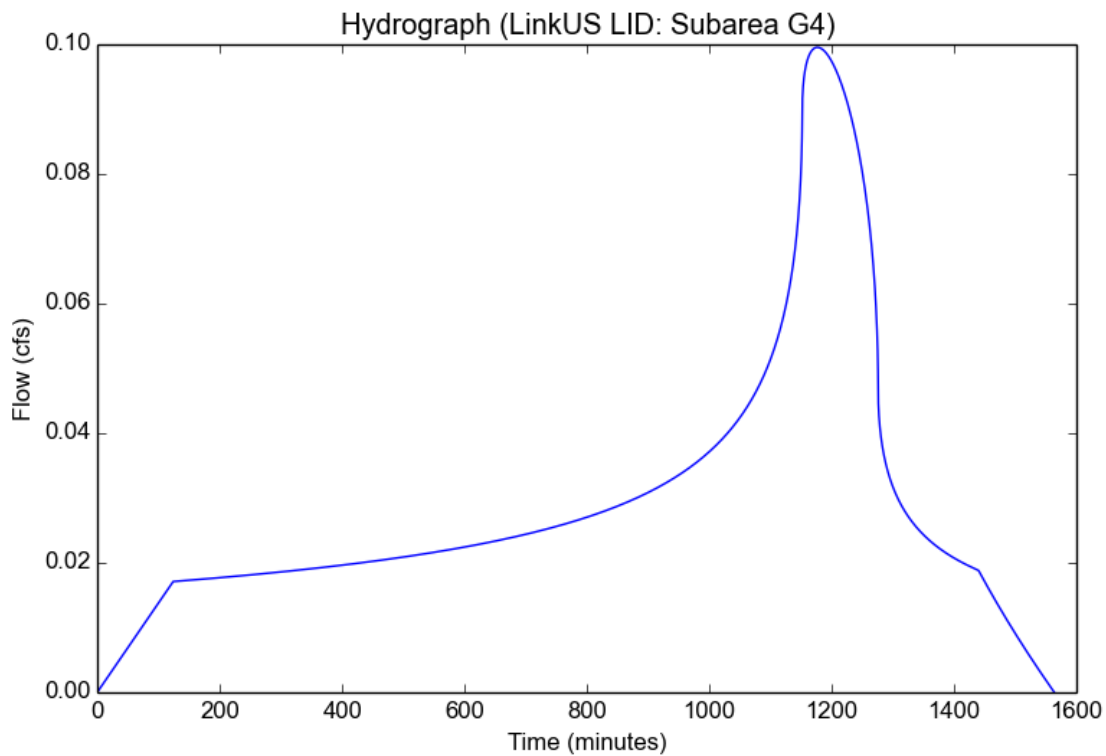

Peak Flow Hydrologic Analysis

Input Parameters

Project Name	LinkUS LID
Subarea ID	Subarea H
Area (ac)	0.97
Flow Path Length (ft)	1045.0
Flow Path Slope (vft/hft)	0.03
85th Percentile Rainfall Depth (in)	1.0
Percent Impervious	0.15
Soil Type	6
Design Storm Frequency	85th percentile storm
Fire Factor	0
LID	True

Output Results

Modeled (85th percentile storm) Rainfall Depth (in)	1.0
Peak Intensity (in/hr)	0.1612
Undeveloped Runoff Coefficient (Cu)	0.1
Developed Runoff Coefficient (Cd)	0.22
Time of Concentration (min)	81.0
Clear Peak Flow Rate (cfs)	0.0344
Burned Peak Flow Rate (cfs)	0.0344
24-Hr Clear Runoff Volume (ac-ft)	0.0176
24-Hr Clear Runoff Volume (cu-ft)	768.3065

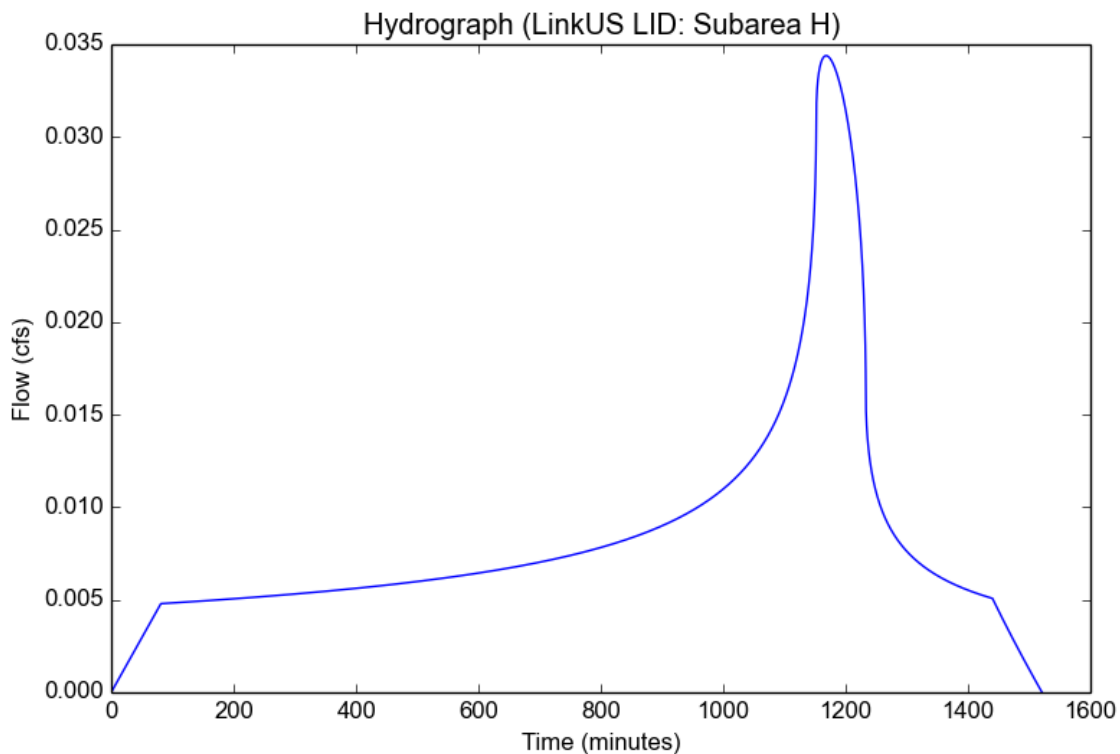

Peak Flow Hydrologic Analysis

Input Parameters

Project Name	LinkUS LID
Subarea ID	Subarea I
Area (ac)	5.01
Flow Path Length (ft)	649.0
Flow Path Slope (vft/hft)	0.0023
85th Percentile Rainfall Depth (in)	1.0
Percent Impervious	0.63
Soil Type	6
Design Storm Frequency	85th percentile storm
Fire Factor	0
LID	True

Output Results

Modeled (85th percentile storm) Rainfall Depth (in)	1.0
Peak Intensity (in/hr)	0.2081
Undeveloped Runoff Coefficient (Cu)	0.1
Developed Runoff Coefficient (Cd)	0.604
Time of Concentration (min)	47.0
Clear Peak Flow Rate (cfs)	0.6298
Burned Peak Flow Rate (cfs)	0.6298
24-Hr Clear Runoff Volume (ac-ft)	0.2501
24-Hr Clear Runoff Volume (cu-ft)	10894.0544

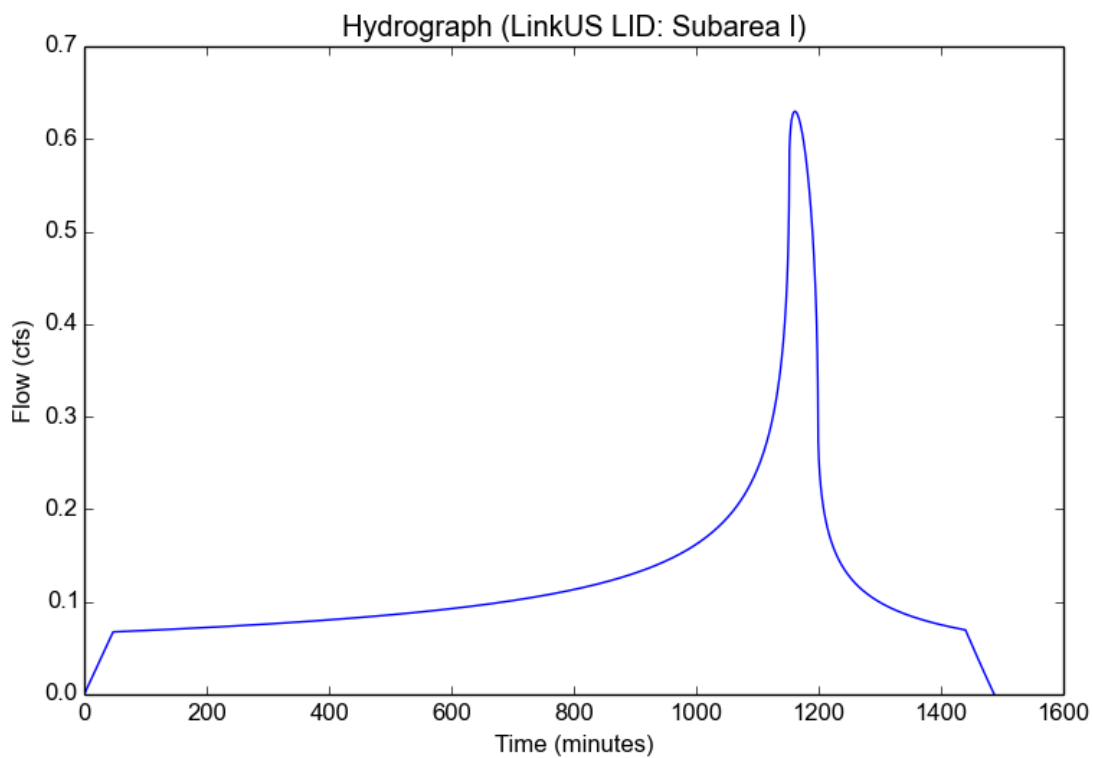

Peak Flow Hydrologic Analysis

Input Parameters

Project Name	LinkUS LID
Subarea ID	Subarea J
Area (ac)	0.86
Flow Path Length (ft)	850.0
Flow Path Slope (vft/hft)	0.0023
85th Percentile Rainfall Depth (in)	1.0
Percent Impervious	0.15
Soil Type	6
Design Storm Frequency	85th percentile storm
Fire Factor	0
LID	True

Output Results

Modeled (85th percentile storm) Rainfall Depth (in)	1.0
Peak Intensity (in/hr)	0.1384
Undeveloped Runoff Coefficient (Cu)	0.1
Developed Runoff Coefficient (Cd)	0.22
Time of Concentration (min)	112.0
Clear Peak Flow Rate (cfs)	0.0262
Burned Peak Flow Rate (cfs)	0.0262
24-Hr Clear Runoff Volume (ac-ft)	0.0156
24-Hr Clear Runoff Volume (cu-ft)	681.2351

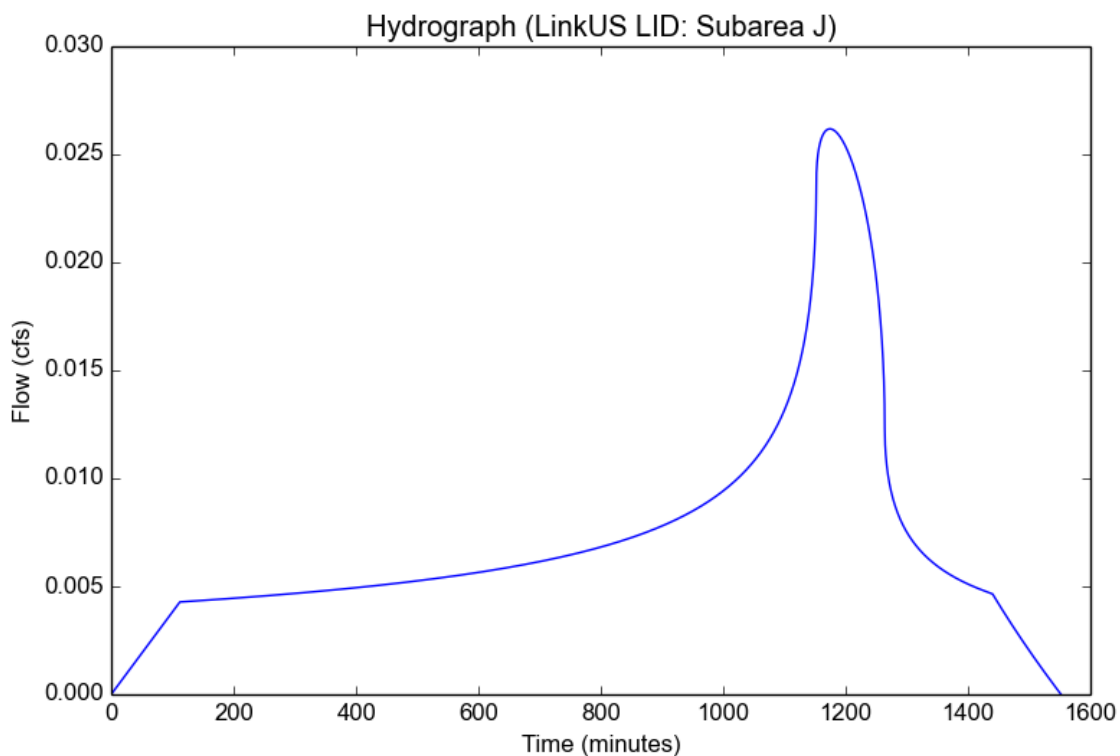

Appendix C: Low Impact Development Exhibits

(THIS PAGE INTENTIONALLY LEFT BLANK)

SEE EXHIBIT 1 OF 7
MATCH LINE



AREA I
63% IMPERVIOUS
A=5.01 ACRE
Qm=0.63 cfs
Vm=10894 ft³

STORMFILTER
VAULT

NO CHANGES TO EXISTING
DRAINAGE PATTERN; MORE
INFORMATION ON
STORMWATER WILL BE
PROVIDED AS THE
PROJECT PROGRESSES

MATCH LINE
SEE EXHIBIT 4 OF 7

- LEGEND:**
- AREA I
 - PROPOSED STORM DRAIN
 - EXISTING STORM DRAIN
 - DRAINAGE SUB-AREA BOUNDARY
 - PROJECT FOOTPRINT
 - STORMFILTER VAULT
 - TRACK UNDERDRAIN

D R A F T



LINK UNION STATION
PRELIMINARY LID EXHIBIT
SHEET 2 OF 7

SCALE: 1"=100'
DATE: 04-13-2018

11/14/2018 5:44:32 PM
 C:\pwworking\sac\06852905\SUSMP2.dwg PlotStamp.tbl
 C:\Users\Nihal.M\p\d06852905\04-13-2018-Exhibit-FW-CLR.plt
 C:\pwworking\sac\06852905\SUSMP2.dwg PlotStamp.tbl

SEE EXHIBIT 3 OF 7
MATCH LINE

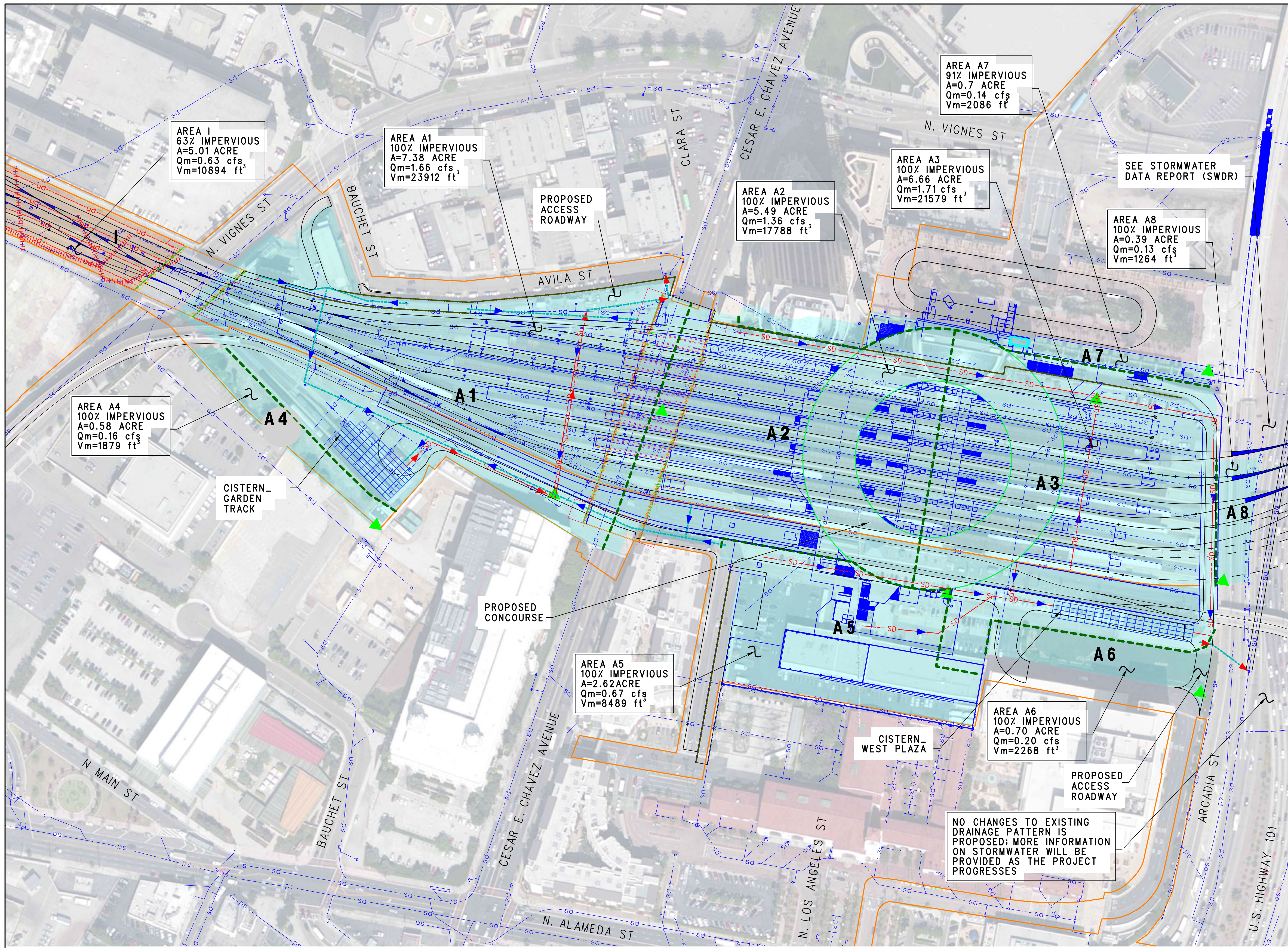
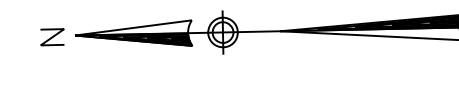

AREA I
63% IMPERVIOUS
A=5.01 ACRE
Qm=0.63 cfs
Vm=10894 ft³

AREA A1
100% IMPERVIOUS
A=7.38 ACRE
Qm=1.66 cfs
Vm=23912 ft³

AREA A2
100% IMPERVIOUS
A=5.49 ACRE
Qm=1.36 cfs
Vm=17788 ft³

AREA A3
100% IMPERVIOUS
A=6.66 ACRE
Qm=1.71 cfs
Vm=21579 ft³

AREA A8
100% IMPERVIOUS
A=0.39 ACRE
Qm=0.13 cfs
Vm=1264 ft³

AREA A4
100% IMPERVIOUS
A=0.58 ACRE
Qm=0.16 cfs
Vm=1879 ft³

AREA A5
100% IMPERVIOUS
A=2.62 ACRE
Qm=0.67 cfs
Vm=8489 ft³

AREA A6
100% IMPERVIOUS
A=0.70 ACRE
Qm=0.20 cfs
Vm=2268 ft³

NO CHANGES TO EXISTING
DRAINAGE PATTERN IS
PROPOSED; MORE INFORMATION
ON STORMWATER WILL BE
PROVIDED AS THE PROJECT
PROGRESSES

SEE STORMWATER
DATA REPORT (SWDR)

LEGEND:

- AREA I
- AREA A
(A1, A2, A3, A4, A5, A6, A7, A8)
- PROPOSED STORM DRAIN
- EXISTING STORM DRAIN
- DRAINAGE SUB-AREA BOUNDARY
- CISTERN
- PROJECT FOOTPRINT
- TRACK UNDERDRAIN

SEE EXHIBIT 2 OF 7
MATCH LINE

MATCH LINE
SEE EXHIBIT 5 OF 7

D R A F T



LINK UNION STATION
PRELIMINARY LID EXHIBIT
SHEET 4 OF 7

SCALE: 1"=100'
DATE: 04-13-2018

11/16/2018 3:57:15 PM
 c:\pwworking\src\d0652905\USUSMP4.dgn
 p:\pwworking\src\d0652905\USUSMP4.dwg
 c:\pwworking\src\d0652905\USUSMP4.dwg
 c:\pwworking\src\d0652905\USUSMP4.dwg

11/14/2018 5:28:59 PM
 c:\pwworking\src\d0652905\USUSWP5.dgn
 p:\pwworking\src\d0652905\USUSWP5.dwg
 c:\pwworking\src\d0652905\USUSWP5.dwg
 c:\pwworking\src\d0652905\USUSWP5.dwg

SEE EXHIBIT 3 OF 7
MATCH LINE

SEE EXHIBIT 4 OF 7
MATCH LINE

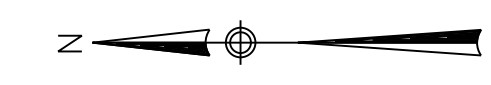
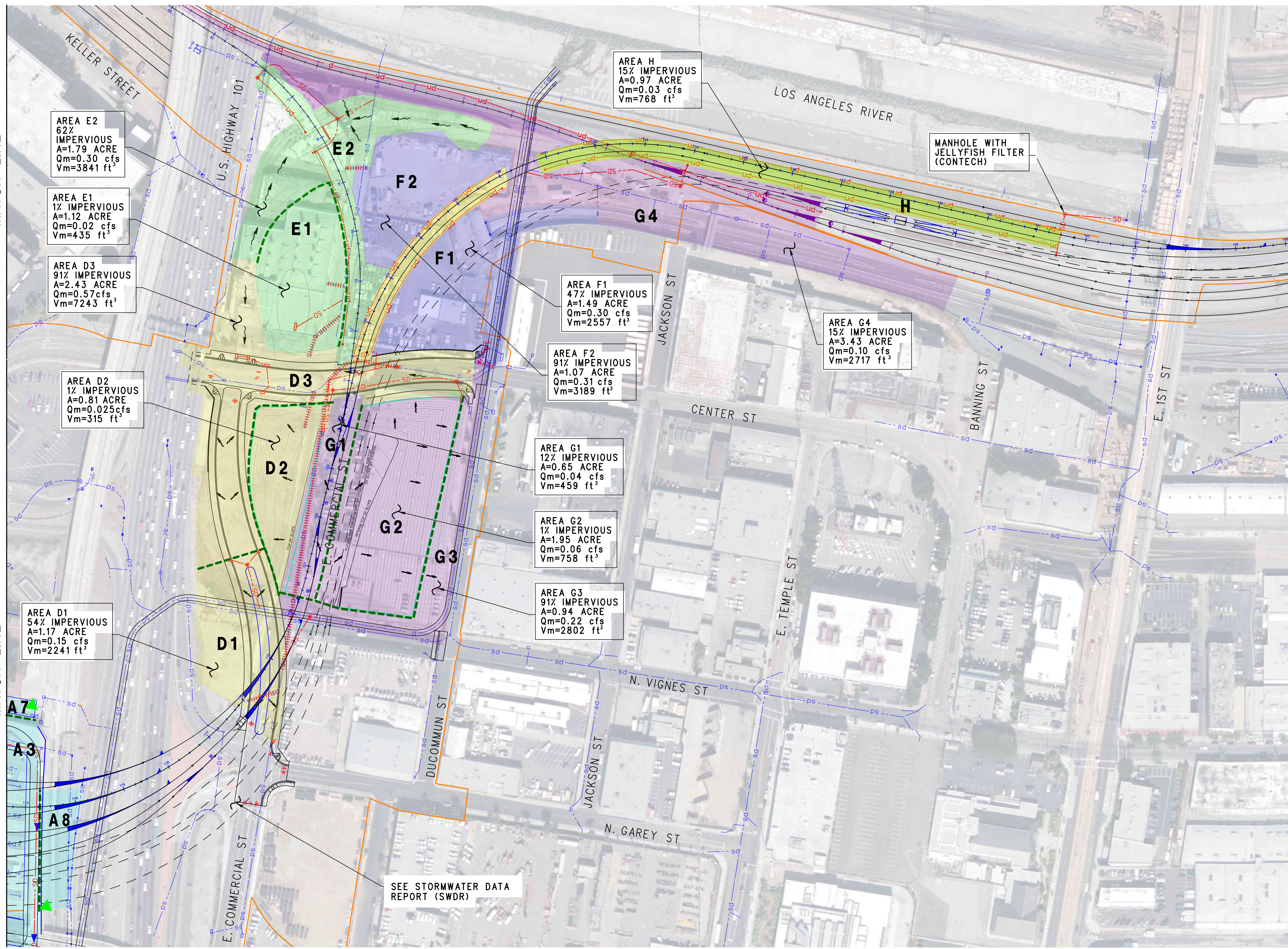

NOTE:
 LOCATIONS OF BIORETENTION WITH UNDERDRAIN NOT SHOWN FOR EACH DRAINAGE AREA

LEGEND:

	AREA A (A3, A7, A8)
	AREA D (D1, D2, D3)
	AREA E (E1, E2)
	AREA F (F1, F2)
	AREA G (G1, G2, G3, G4)
	AREA H
	PROPOSED STORM DRAIN
	EXISTING STORM DRAIN
	DRAINAGE SUB-AREA BOUNDARY
	PROJECT FOOTPRINT
	TRACK UNDERDRAIN

SEE STORMWATER DATA REPORT (SWDR)

D R A F T

		LINK UNION STATION PRELIMINARY LID EXHIBIT SHEET 5 OF 7	SCALE: 1"=100' DATE: 04-13-2018
--	--	---	------------------------------------

11/14/2018 5:59:01 PM
 C:\pwworking\sac\06852905\USM\6.dgn\0000232098\PlotStamp.tbl
 C:\Users\hina\My Documents\0000232098\USM\6.dgn\0000232098\PlotStamp.tbl
 C:\pwworking\sac\06852905\USM\6.dgn\0000232098\PlotStamp.tbl

SEE EXHIBIT 5 OF 7
MATCH LINE

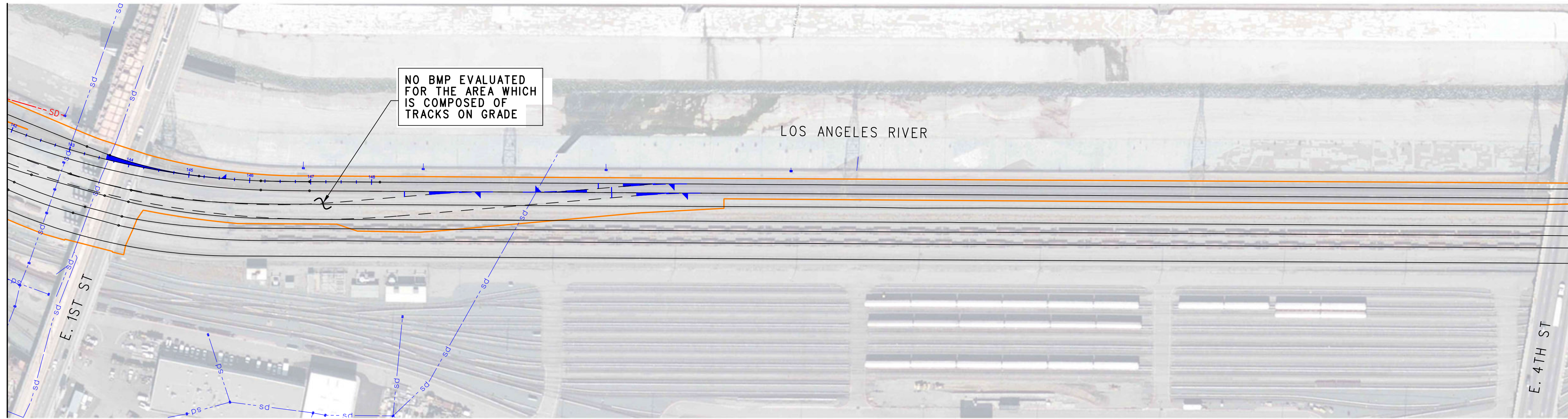

MATCH LINE
SEE BELOW LEFT

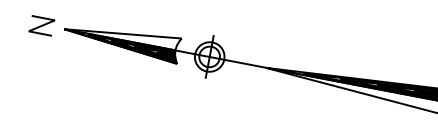

SEE ABOVE RIGHT
MATCH LINE

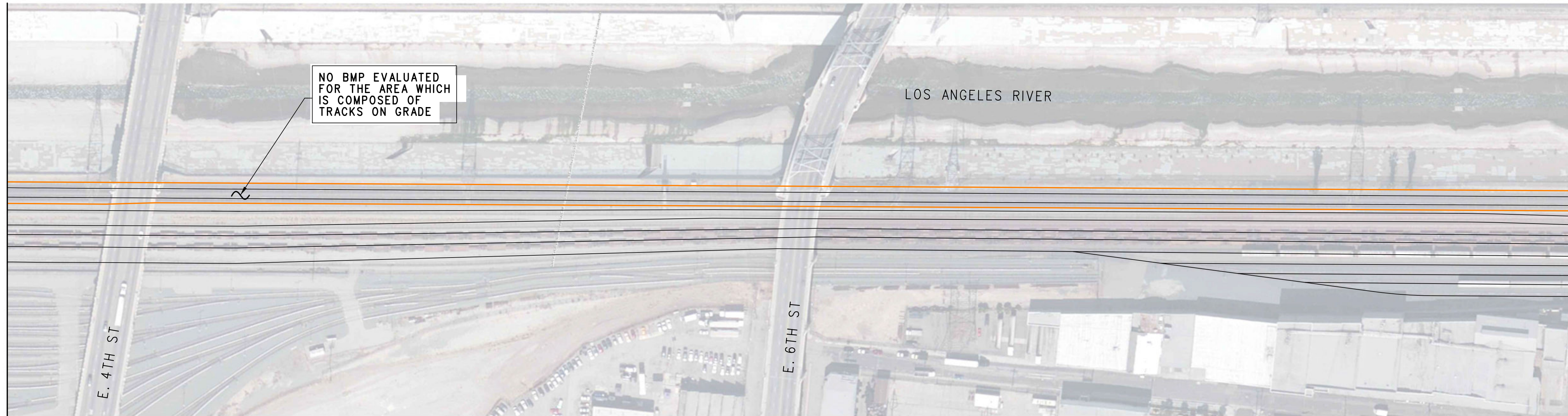

MATCH LINE
SEE EXHIBIT 7 OF 7

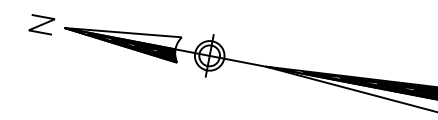

LEGEND:

-  sd EXISTING STORM DRAIN
-  PROJECT FOOTPRINT

D R A F T



LINK UNION STATION
PRELIMINARY LID EXHIBIT
SHEET 6 OF 7

SCALE: 1"=100'
DATE: 04-13-2018

11/14/2018 6:01:52 PM
c:\pwworking\src\d0652905\USUSMP7.dgn
p:\pwworking\src\d0652905\USUSMP7.dgn
c:\pwworking\src\d0652905\USUSMP7.dgn
c:\pwworking\src\d0652905\USUSMP7.dgn

SEE EXHIBIT 6 OF 7
MATCH LINE

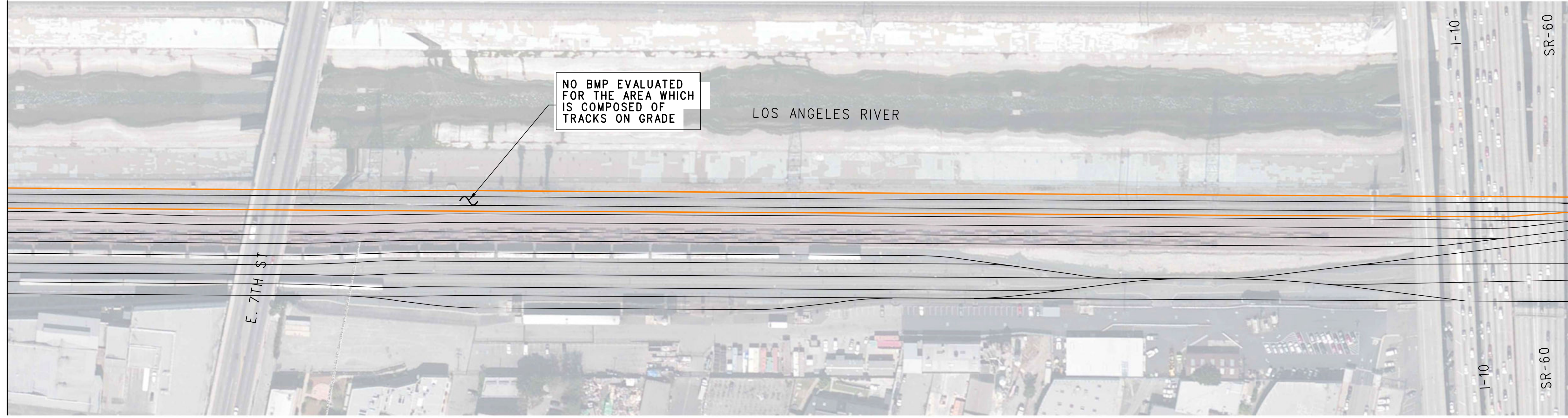

MATCH LINE
SEE BELOW LEFT

SEE ABOVE RIGHT
MATCH LINE

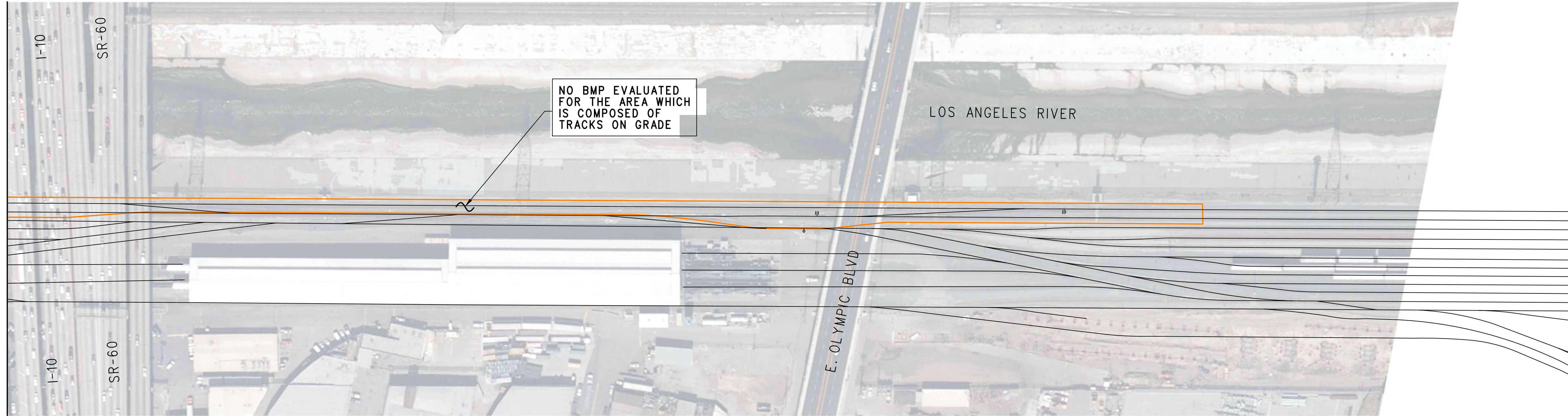

LEGEND:

— PROJECT FOOTPRINT

D R A F T



LINK UNION STATION
PRELIMINARY LID EXHIBIT
SHEET 7 OF 7

SCALE: 1"=100'

DATE: 04-13-2018

Appendix D: Stormwater Process Diagram

(THIS PAGE INTENTIONALLY LEFT BLANK)

Link Union Station Stormwater Process Diagram

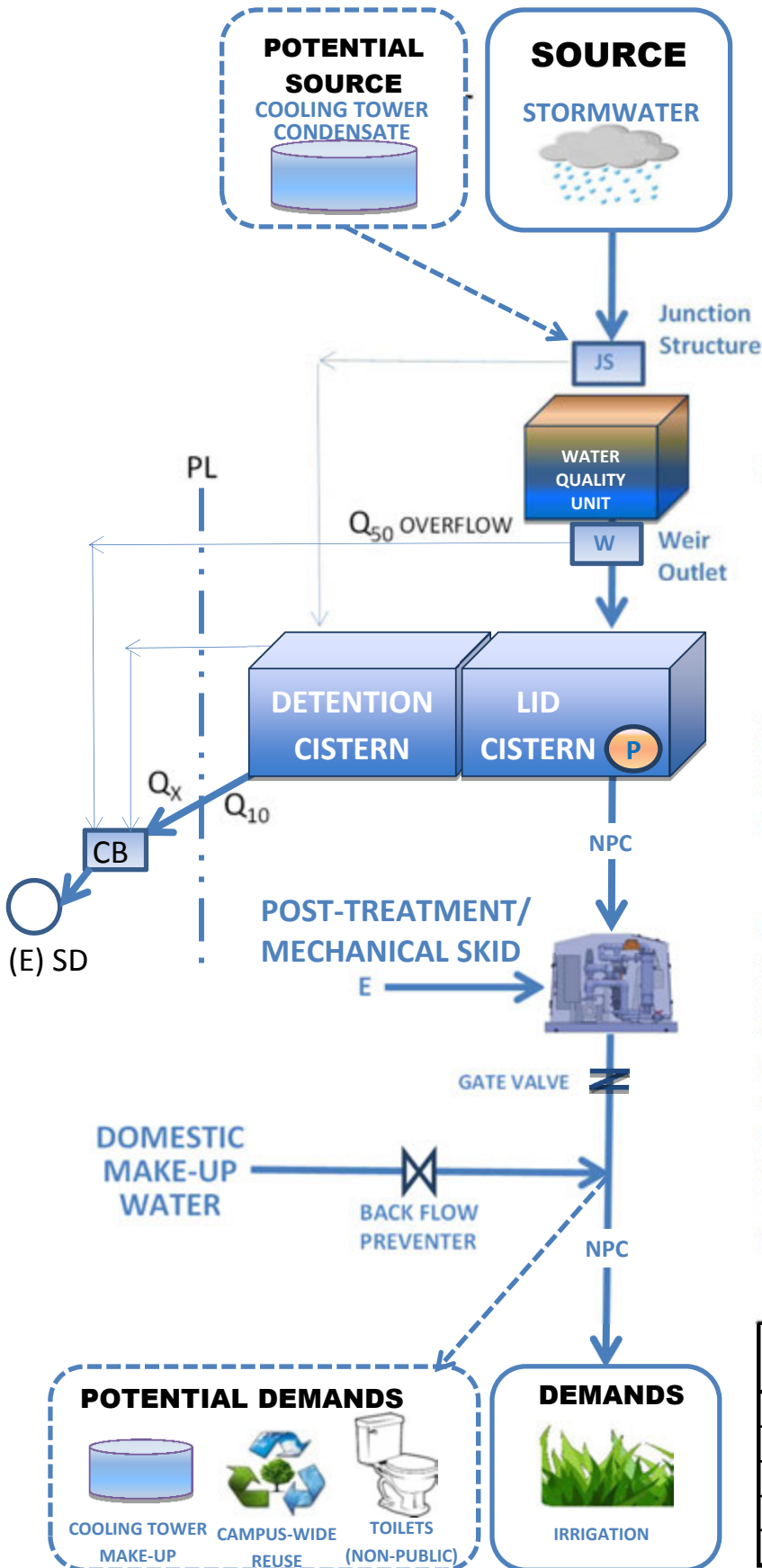

Source	Volume Per Design Storm	
	cu-ft	gal
Stormwater (Q50)	470,779	3,521,425

Condensate is not considered at this time

LID (85th)	Volume		Flow
	cu-ft	gal	cfs
	77,178	577,288	5.88

LID (85th)

10-Year Pre 50-Year Post Delta (50yr - 10yr)	Volume		Flow
	cu-ft	gal	cfs
	242,655	1,815,057	33.98
	470,779	3,521,425	64.77
	228,124	1,706,368	30.79

10-Year Pre
50-Year Post
Delta
(50yr - 10yr)

Notes:

1. Assumes public line is Q10
2. Qx size to be verified after property line
3. Post-treatment includes UV disinfection and microfiltration
4. NPC = Non-Potable Cistern
5. PL = Property Line
6. CB = Catch Basin
7. Detention cistern sizing will be the difference of the total detention and LID sizing

Demands	Volume / Day	
	cu-ft	gal
Irrigation		
Cooling Tower		
Campus-wide reuse		
Toilets (non-Public)		
Total		

(THIS PAGE INTENTIONALLY LEFT BLANK)

Appendix E: Cistern Details

The cistern details are used as a reference for preliminary design purposes only and are subject to change.

(THIS PAGE INTENTIONALLY LEFT BLANK)

STORMCAPTURE[®]

*StormCapture Modular Stormwater Management System
for Infiltration, Detention, Retention and Treatment*



Call us today **(800) 579-8819** or visit our website for detailed product information, drawings and design tools at www.oldcastlestormwater.com

StormCapture[®] Module

Large Storage Capacity

Smaller system footprint for greater design flexibility.

Traffic Loading

Only requires 6" of cover.

Modular Design

Precast concrete modules measure 8' wide by 16' long OD, (7' x 15' ID), with customizable heights.

Custom Sizes

Available in internal heights from 2' to 14' to best-fit site needs.

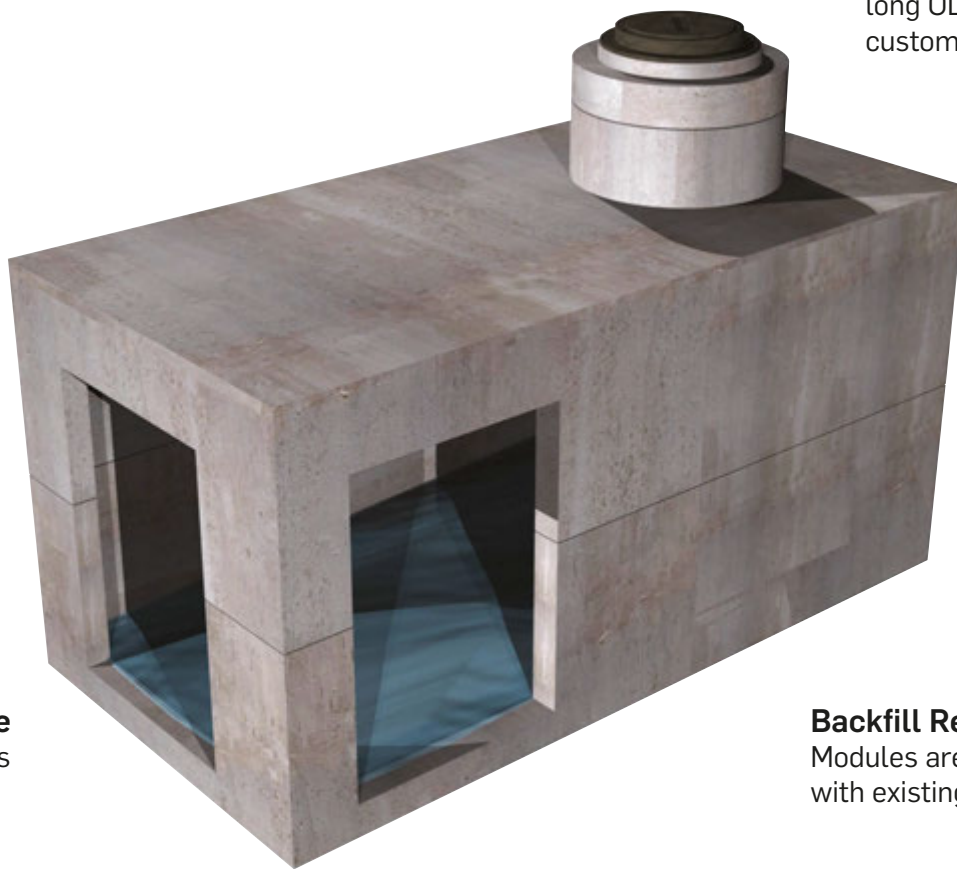

Easy to Install

Fast installation with minimal handling.

Design Assistance

Let our professionals customize for your specific needs.

Backfill Requirements

Modules are typically backfilled with existing site materials.

Treatment Train

Available with pre-treatment, post-treatment, or both.

Construction Site Friendly

Contractor does not have to relinquish any ground on the site once the StormCapture system is installed.



INSTALLED IN JUST ONE DAY

Module Sizes

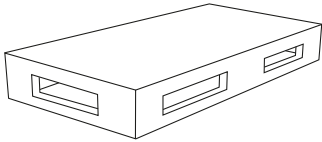

SC1 - Single piece modules can be used for applications from 2' to 7' tall. Appropriate for cisterns, infiltration, detention and retention systems. SC1 modules are typically installed on minimally compacted gravel base, depending on specific project requirements.

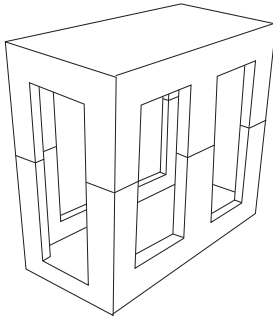

SC2 - Two piece modules can be used for applications from 7' to 14' tall for maximum storage capacity in a condensed footprint. Appropriate for cisterns, infiltration, detention and retention systems. SC2 modules are typically installed on compacted native subgrade.

Module Sizes & Capacities

Modules are 8'x16' outside dimensions. Capacity varies by configuration of openings.

Inside Dimensions (ft)	Capacity Range (ft ³)	Inside Dimensions (ft)	Capacity Range (ft ³)
7x15x2	210-212	7x15x9	945-1,027
7x15x3	315-325	7x15x10	1,050-1,140
7x15x4	420-442	7x15x11	1,155-1,257
7x15x5	525-559	7x15x12	1,260-1,374
7x15x6	630-676	7x15x13*	1,365-1,491
7x15x7	735-793	7x15x14*	1,470-1,608
7x15x8	840-910		

* Special design considerations required and limited availability

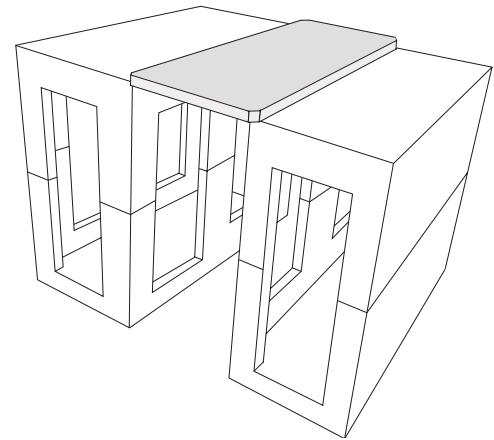

Link Slab - Unique design allows for significant reduction in the quantity of modules and associated costs, while providing maximum storage capacity.

Endless Configurations

Contact us today to start designing your system!

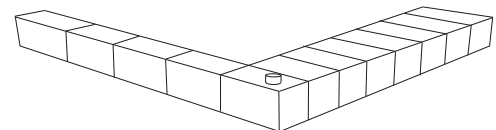
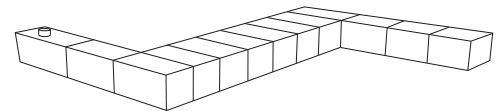
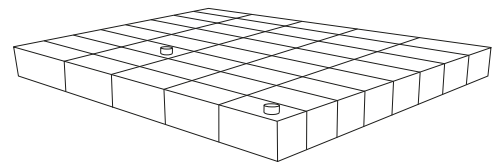

(THIS PAGE INTENTIONALLY LEFT BLANK)

Appendix F: Bioretention Sizing

(THIS PAGE INTENTIONALLY LEFT BLANK)

LINK US BIORETENTION Sizing Area D1

$$A_{min} = V_{Design} / [(T_{fill} \times K_{Sat, Design}) / 12 + d_p]$$

Parameters	Parameters	Notes	
Mitigated Volume (ft ³)	V_m	Per HydroCalc	2,240
Design Volume (ft ³)	$V_{design} = 1.5 V_m$	Biofilterion facilities to be sized to capture and treat 150% of the design capture volume	3,360
Measured Infiltrate Rate (in/hr)	$K_{sat, media}$	Assumed 5 in/hr	5.0
Factor of Safety	FS	FS=2 if soil infiltration test and geotechnical report from professional GE is done, FS= 6 if only a boring was done.	6.0
Design Infiltrate Rate (in/hr)	$K_{sat, design}$		0.8
Time to fill (hrs)	T_{fill}	$T_{fill} = 3$ hrs, unless a hydrologic routing model is used	3.0
Maximum Ponding Depth (ft)	$d_{p,max}$	Maximum = 18 in	1.5
Design Infiltration Area (sf)	A_{min}	$A_{min} = V_{Design} / [(T_{fill} \times K_{Sat, Design}) / 12 + d_p]$	1,967

LINK US BIORETENTION Sizing Area D3

$$A_{min} = V_{Design} / [(T_{fill} \times K_{Sat, Design}) / 12 + d_p]$$

Parameters	Parameters	Notes	
Mitigated Volume (ft ³)	V_m	Per HydroCalc	7,243
Design Volume (ft ³)	$V_{design} = 1.5 V_m$	Biofilterion facilities to be sized to capture and treat 150% of the design capture volume	10,865
Measured Infiltrate Rate (in/hr)	$K_{sat, media}$	Assumed 5 in/hr	5.0
Factor of Safety	FS	FS=2 if soil infiltration test and geotechnical report from professional GE is done, FS=6 if only a boring was done.	6.0
Design Infiltrate Rate (in/hr)	$K_{sat, design}$		0.8
Time to fill (hrs)	T_{fill}	$T_{fill} = 3$ hrs, unless a hydrologic routing model is used	3.0
Maximum Ponding Depth (ft)	$d_{p,max}$	Maximum = 18 in	1.5
Design Infiltration Area (sf)	A_{min}	$A_{min} = V_{Design} / [(T_{fill} \times K_{Sat, Design}) / 12 + d_p]$	6,360

LINK US BIORETENTION Sizing Area E2

$$A_{\min} = V_{\text{Design}} / [(T_{\text{fill}} \times K_{\text{Sat, Design}}) / 12 + d_p]$$

Parameters	Parameters	Notes	
Mitigated Volume (ft ³)	V_m	Per HydroCalc	3,840
Design Volume (ft ³)	$V_{\text{design}} = 1.5 V_m$	Biofilterion facilities to be sized to capture and treat 150% of the design capture volume	5,760
Measured Infiltrate Rate (in/hr)	$K_{\text{sat, media}}$	Assumed 5 in/hr	5.0
Factor of Safety	FS	FS=2 if soil infiltration test and geotechnical report from professional GE is done, FS= 6 if only a boring is done	6.0
Design Infiltrate Rate (in/hr)	$K_{\text{sat, design}}$		0.8
Time to fill (hrs)	T_{fill}	$T_{\text{fill}} = 3$ hrs, unless a hydrologic routing model is used	3.0
Maximum Ponding Depth (ft)	$d_{p, \text{max}}$	Maximum = 18 in	1.5
Design Infiltration Area (sf)	A_{\min}	$A_{\min} = V_{\text{Design}} / [(T_{\text{fill}} \times K_{\text{Sat, Design}}) / 12 + d_p]$	3,372

(THIS PAGE INTENTIONALLY LEFT BLANK)

Appendix G: Contech StormFilter

(THIS PAGE INTENTIONALLY LEFT BLANK)

STORMFILTER DESIGN NOTES

STORMFILTER TREATMENT CAPACITY IS A FUNCTION OF THE CARTRIDGE SELECTION AND THE NUMBER OF CARTRIDGES. THE STANDARD VAULT STYLE IS SHOWN WITH THE MAXIMUM NUMBER OF CARTRIDGES (12). VAULT STYLE OPTIONS INCLUDE OUTLET BAY (7).

STORMFILTER 8X6 PEAK HYDRAULIC CAPACITY IS 1.8 CFS. IF THE SITE CONDITIONS EXCEED 1.8 CFS AN UPSTREAM BYPASS STRUCTURE IS REQUIRED.

CARTRIDGE SELECTION

CARTRIDGE HEIGHT	27"		18"		LOW DROP	
RECOMMENDED HYDRAULIC DROP (H)	3.05'		2.3'		1.8'	
SPECIFIC FLOW RATE (gpm/sf)	2 gpm/ft ²	1 gpm/ft ²	2 gpm/ft ²	1 gpm/ft ²	2 gpm/ft ²	1 gpm/ft ²
CARTRIDGE FLOW RATE (gpm)	22.5	11.25	15	7.5	10	5

SITE SPECIFIC DATA REQUIREMENTS

STRUCTURE ID	*
WATER QUALITY FLOW RATE (cfs)	*
PEAK FLOW RATE (cfs)	*
RETURN PERIOD OF PEAK FLOW (yrs)	*
# OF CARTRIDGES REQUIRED	*
CARTRIDGE FLOW RATE	*
MEDIA TYPE (CSF, PERLITE, ZPG, GAC, PHS)	*

PIPE DATA:	I.E.	MATERIAL	DIAMETER
INLET PIPE #1	*	*	*
INLET PIPE #2	*	*	*
OUTLET PIPE	*	*	*

UPSTREAM RIM ELEVATION	*
DOWNSTREAM RIM ELEVATION	*

ANTI-FLOTATION BALLAST	WIDTH	HEIGHT
	*	*

NOTES/SPECIAL REQUIREMENTS:

* PER ENGINEER OF RECORD

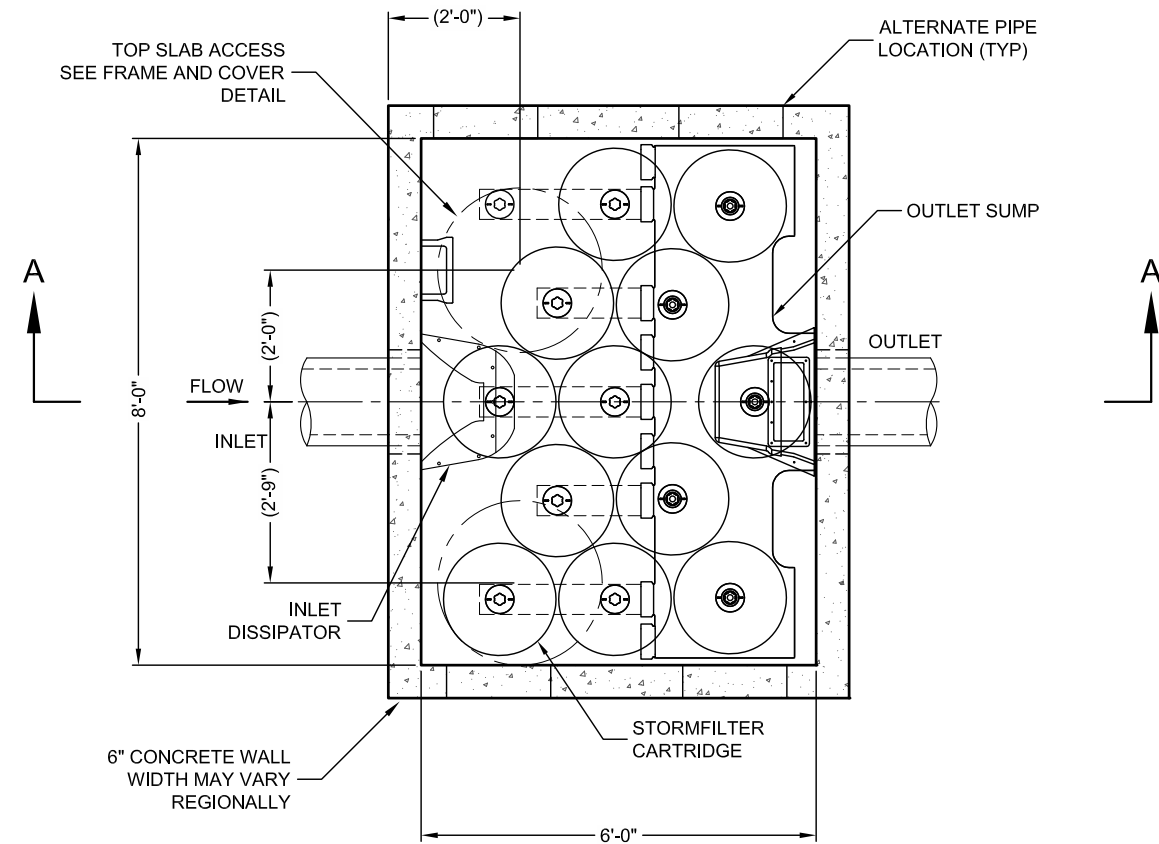

SECTION B-B
VAULT STYLE: OUTLET SUMP (NIB)

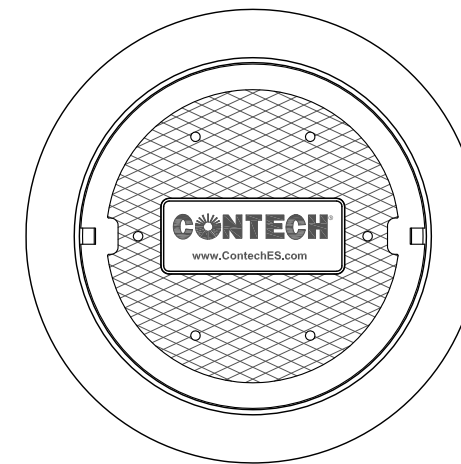

FRAME AND COVER
(DIAMETER VARIES)
N.T.S.

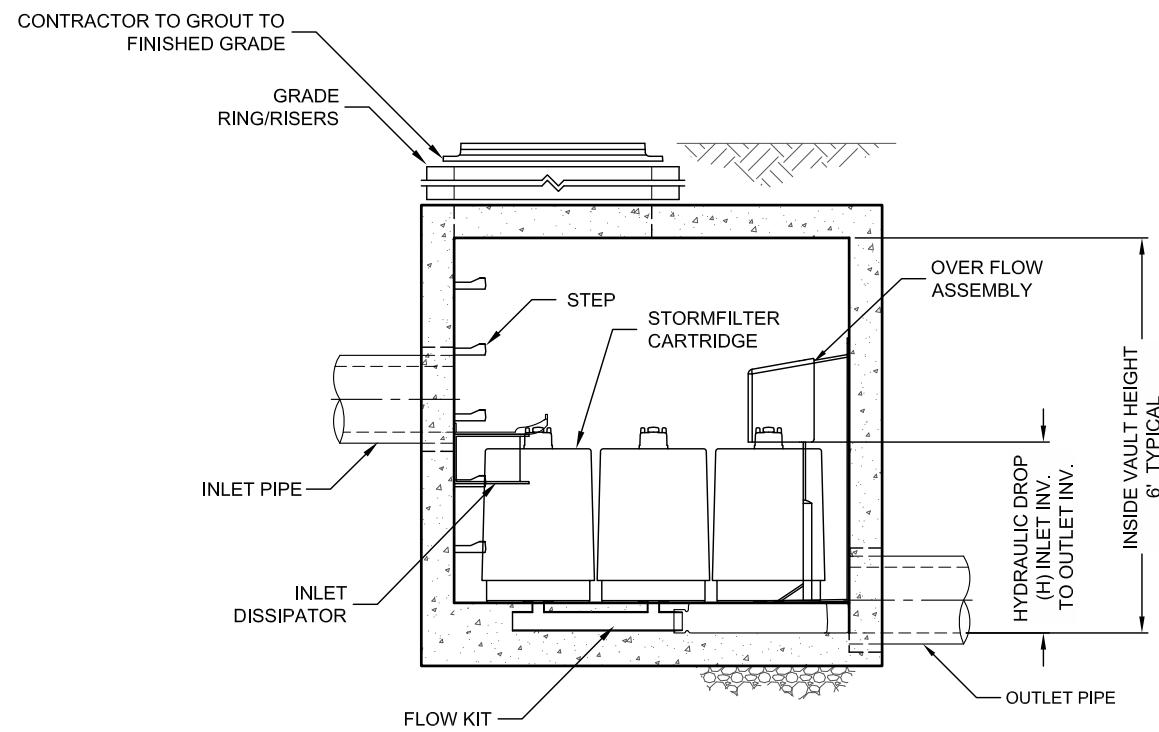

SECTION A-A

GENERAL NOTES

- CONTECH TO PROVIDE ALL MATERIALS UNLESS NOTED OTHERWISE.
- DIMENSIONS MARKED WITH () ARE REFERENCE DIMENSIONS. ACTUAL DIMENSIONS MAY VARY.
- FOR SITE SPECIFIC DRAWINGS WITH DETAILED VAULT DIMENSIONS AND WEIGHTS, PLEASE CONTACT YOUR CONTECH REPRESENTATIVE. www.ContechES.com
- STORMFILTER WATER QUALITY STRUCTURE SHALL BE IN ACCORDANCE WITH ALL DESIGN DATA AND INFORMATION CONTAINED IN THIS DRAWING.
- STRUCTURE SHALL MEET AASHTO HS20 AND CASTINGS SHALL MEET AASHTO M306 LOAD RATING, ASSUMING GROUNDWATER ELEVATION AT, OR BELOW, THE OUTLET PIPE INVERT ELEVATION. ENGINEER OF RECORD TO CONFIRM ACTUAL GROUNDWATER ELEVATION
- FILTER CARTRIDGES SHALL BE MEDIA-FILLED, PASSIVE, SIPHON ACTUATED, RADIAL FLOW, AND SELF CLEANING. RADIAL MEDIA DEPTH SHALL BE 7-INCHES. FILTER MEDIA CONTACT TIME SHALL BE AT LEAST 39 SECONDS.
- SPECIFIC FLOW RATE IS EQUAL TO THE FILTER TREATMENT CAPACITY (gpm) DIVIDED BY THE FILTER CONTACT SURFACE AREA (sq ft).

INSTALLATION NOTES

- ANY SUB-BASE, BACKFILL DEPTH, AND/OR ANTI-FLOTATION PROVISIONS ARE SITE-SPECIFIC DESIGN CONSIDERATIONS AND SHALL BE SPECIFIED BY ENGINEER OF RECORD.
- CONTRACTOR TO PROVIDE EQUIPMENT WITH SUFFICIENT LIFTING AND REACH CAPACITY TO LIFT AND SET THE STORMFILTER VAULT (LIFTING CLUTCHES PROVIDED).
- CONTRACTOR TO INSTALL JOINT SEALANT BETWEEN ALL VAULT SECTIONS AND ASSEMBLE VAULT.
- CONTRACTOR TO PROVIDE, INSTALL, AND GROUT PIPES. MATCH OUTLET PIPE INVERT WITH OUTLET BAY FLOOR.
- CONTRACTOR TO TAKE APPROPRIATE MEASURES TO PROTECT CARTRIDGES FROM CONSTRUCTION-RELATED EROSION RUNOFF.

CONTECH
ENGINEERED SOLUTIONS LLC

www.ContechES.com
9025 Centre Pointe Dr., Suite 400, West Chester, OH 45069
800-338-1122 513-645-7000 513-645-7993 FAX

SF806
STORMFILTER
STANDARD DETAIL

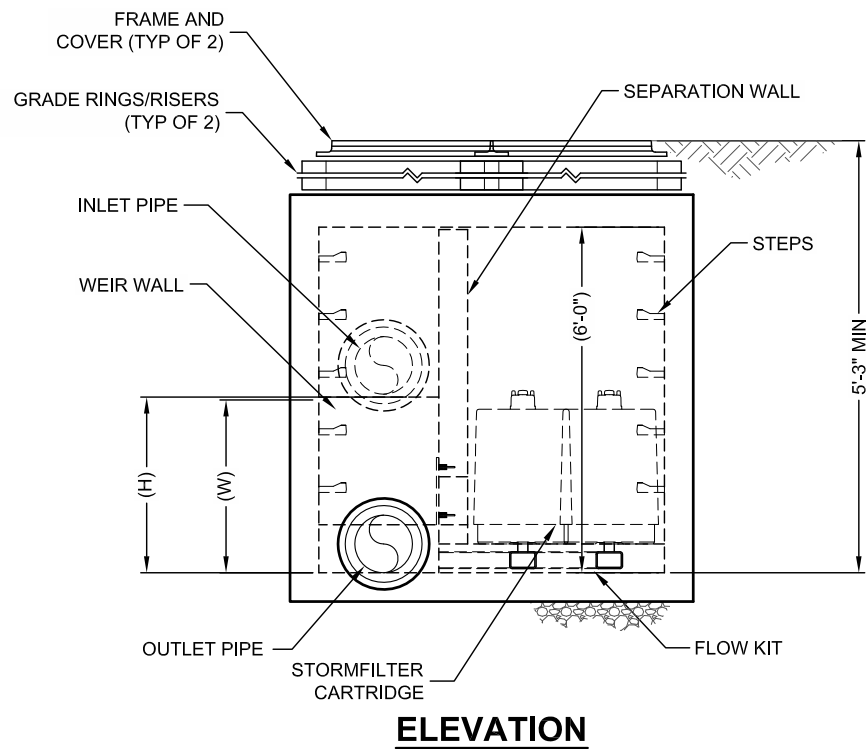
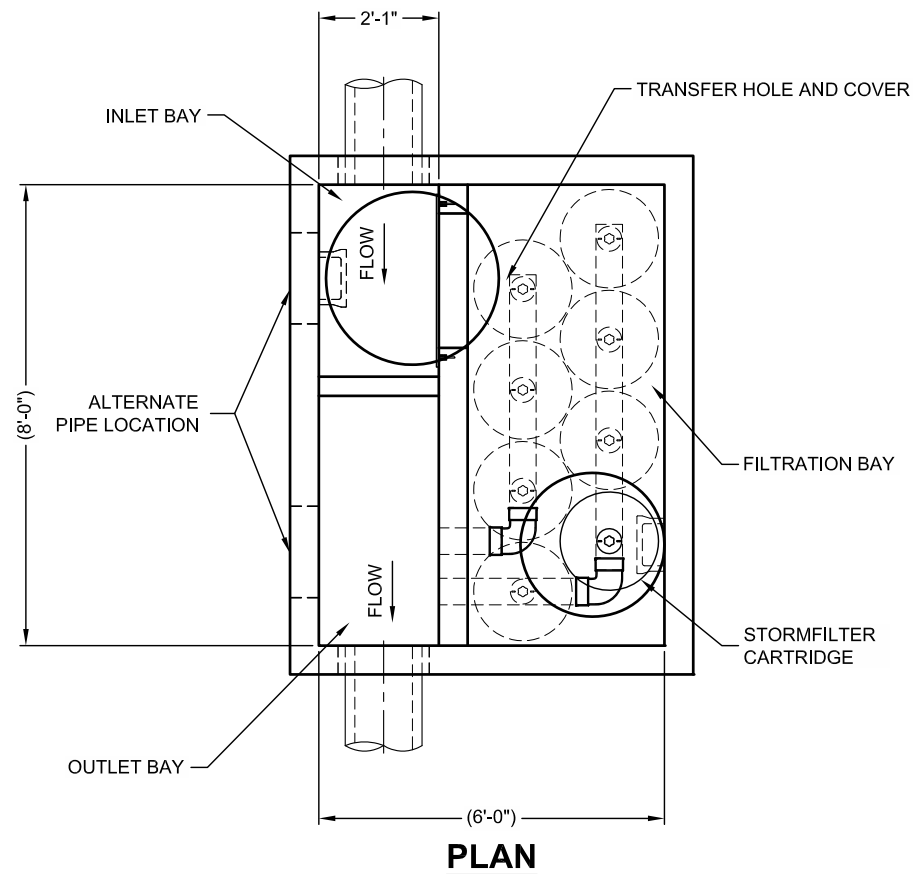

STORMFILTER DESIGN TABLE

- THE 8' x 6' PEAK DIVERSION STORMFILTER TREATMENT CAPACITY VARIES BY CARTRIDGE COUNT AND LOCALLY APPROVED SURFACE AREA SPECIFIC FLOW RATE. PEAK CONVEYANCE CAPACITY TO BE DETERMINED BY ENGINEER OF RECORD.
- THE PEAK DIVERSION STORMFILTER IS AVAILABLE IN A LEFT INLET (AS SHOWN) OR RIGHT INLET CONFIGURATION.
- ALL PARTS AND INTERNAL ASSEMBLY PROVIDED BY CONTECH UNLESS OTHERWISE NOTED.

CARTRIDGE HEIGHT	27"		18"		LOW DROP	
SYSTEM HYDRAULIC DROP (H - REQ'D. MIN.)	3.05'		2.3'		1.8'	
HEIGHT OF WEIR (W)	3.00'		2.25'		1.75'	
TREATMENT BY MEDIA SURFACE AREA	2 gpm/ft ²	1 gpm/ft ²	2 gpm/ft ²	1 gpm/ft ²	2 gpm/ft ²	1 gpm/ft ²
CARTRIDGE FLOW RATE (gpm)	22.5	11.25	15	7.5	10	5

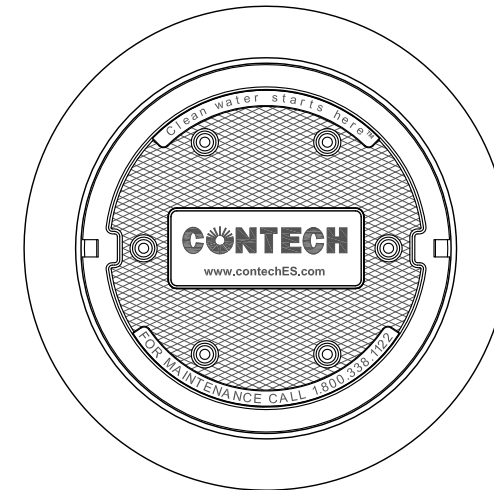

FRAME AND COVER
(DIAMETER VARIES)
N.T.S.

SITE SPECIFIC DATA REQUIREMENTS

STRUCTURE ID	*		
WATER QUALITY FLOW RATE (cfs)	*		
PEAK FLOW RATE (cfs)	*		
RETURN PERIOD OF PEAK FLOW (yrs)	*		
# OF CARTRIDGES REQUIRED	*		
CARTRIDGE FLOW RATE	*		
MEDIA TYPE (CSF, PERLITE, ZPG)	*		
PIPE DATA:	I.E.	MATERIAL	DIAMETER
INLET PIPE	*	*	*
OUTLET PIPE	*	*	*
INLET BAY RIM ELEVATION	*		
FILTER BAY RIM ELEVATION	*		
ANTI-FLOTATION BALLAST	WIDTH	HEIGHT	
	*	*	
NOTES/SPECIAL REQUIREMENTS:			

PERFORMANCE SPECIFICATION

FILTER CARTRIDGES SHALL BE MEDIA-FILLED, PASSIVE, SIPHON ACTUATED, RADIAL FLOW, AND SELF CLEANING. **RADIAL MEDIA DEPTH SHALL BE 7-INCHES**. FILTER MEDIA CONTACT TIME SHALL BE AT LEAST **37 SECONDS**. SPECIFIC FLOW RATE SHALL BE **2 GPM/SF (MAXIMUM)**. SPECIFIC FLOW RATE IS THE MEASURE OF THE FLOW (GPM) DIVIDED BY THE MEDIA SURFACE CONTACT AREA (SF). MEDIA VOLUMETRIC FLOW RATE SHALL BE **6 GPM/CF OF MEDIA (MAXIMUM)**.

GENERAL NOTES

1. CONTECH TO PROVIDE ALL MATERIALS UNLESS NOTED OTHERWISE.
2. DIMENSIONS MARKED WITH () ARE REFERENCE DIMENSIONS. ACTUAL DIMENSIONS MAY VARY.
3. FOR FABRICATION DRAWINGS WITH DETAILED STRUCTURE DIMENSIONS AND WEIGHTS, PLEASE CONTACT YOUR CONTECH REPRESENTATIVE. www.ContechES.com
4. STORMFILTER WATER QUALITY STRUCTURE SHALL BE IN ACCORDANCE WITH ALL DESIGN DATA AND INFORMATION CONTAINED IN THIS DRAWING. CONTRACTOR TO CONFIRM STRUCTURE MEETS REQUIREMENTS OF PROJECT.
5. STRUCTURE SHALL MEET AASHTO HS20 LOAD RATING, ASSUMING EARTH COVER OF 0' - 5' AND GROUNDWATER ELEVATION AT, OR BELOW, THE OUTLET PIPE INVERT ELEVATION. ENGINEER OF RECORD TO CONFIRM ACTUAL GROUNDWATER ELEVATION. CASTINGS SHALL MEET AASHTO M306 AND BE CAST WITH THE CONTECH LOGO.

INSTALLATION NOTES

- A. ANY SUB-BASE, BACKFILL DEPTH, AND/OR ANTI-FLOTATION PROVISIONS ARE SITE-SPECIFIC DESIGN CONSIDERATIONS AND SHALL BE SPECIFIED BY ENGINEER OF RECORD.
- B. CONTRACTOR TO PROVIDE EQUIPMENT WITH SUFFICIENT LIFTING AND REACH CAPACITY TO LIFT AND SET THE STORMFILTER STRUCTURE (LIFTING CLUTCHES PROVIDED).
- C. CONTRACTOR TO INSTALL JOINT SEALANT BETWEEN ALL SECTIONS AND ASSEMBLE STRUCTURE.
- D. CONTRACTOR TO PROVIDE, INSTALL, AND GROUT PIPES. MATCH OUTLET PIPE INVERT WITH OUTLET BAY FLOOR.
- E. CONTRACTOR TO TAKE APPROPRIATE MEASURES TO PROTECT CARTRIDGES FROM CONSTRUCTION-RELATED EROSION RUNOFF.
- F. CONTRACTOR TO REMOVE THE TRANSFER HOLE COVER WHEN THE SYSTEM IS BROUGHT ONLINE.



THIS PRODUCT MAY BE PROTECTED BY ONE OR MORE OF THE FOLLOWING: U.S. PATENT NO. 8,322,228; 8,344,410; 8,714,107; 8,848,767; 8,822,839; 8,848,040; 8,848,041; 8,848,042; 8,848,043; 8,848,044; 8,848,045; 8,848,046; 8,848,047; 8,848,048; 8,848,049; 8,848,050; 8,848,051; 8,848,052; 8,848,053; 8,848,054; 8,848,055; 8,848,056; 8,848,057; 8,848,058; 8,848,059; 8,848,060; 8,848,061; 8,848,062; 8,848,063; 8,848,064; 8,848,065; 8,848,066; 8,848,067; 8,848,068; 8,848,069; 8,848,070; 8,848,071; 8,848,072; 8,848,073; 8,848,074; 8,848,075; 8,848,076; 8,848,077; 8,848,078; 8,848,079; 8,848,080; 8,848,081; 8,848,082; 8,848,083; 8,848,084; 8,848,085; 8,848,086; 8,848,087; 8,848,088; 8,848,089; 8,848,090; 8,848,091; 8,848,092; 8,848,093; 8,848,094; 8,848,095; 8,848,096; 8,848,097; 8,848,098; 8,848,099; 8,848,100; 8,848,101; 8,848,102; 8,848,103; 8,848,104; 8,848,105; 8,848,106; 8,848,107; 8,848,108; 8,848,109; 8,848,110; 8,848,111; 8,848,112; 8,848,113; 8,848,114; 8,848,115; 8,848,116; 8,848,117; 8,848,118; 8,848,119; 8,848,120; 8,848,121; 8,848,122; 8,848,123; 8,848,124; 8,848,125; 8,848,126; 8,848,127; 8,848,128; 8,848,129; 8,848,130; 8,848,131; 8,848,132; 8,848,133; 8,848,134; 8,848,135; 8,848,136; 8,848,137; 8,848,138; 8,848,139; 8,848,140; 8,848,141; 8,848,142; 8,848,143; 8,848,144; 8,848,145; 8,848,146; 8,848,147; 8,848,148; 8,848,149; 8,848,150; 8,848,151; 8,848,152; 8,848,153; 8,848,154; 8,848,155; 8,848,156; 8,848,157; 8,848,158; 8,848,159; 8,848,160; 8,848,161; 8,848,162; 8,848,163; 8,848,164; 8,848,165; 8,848,166; 8,848,167; 8,848,168; 8,848,169; 8,848,170; 8,848,171; 8,848,172; 8,848,173; 8,848,174; 8,848,175; 8,848,176; 8,848,177; 8,848,178; 8,848,179; 8,848,180; 8,848,181; 8,848,182; 8,848,183; 8,848,184; 8,848,185; 8,848,186; 8,848,187; 8,848,188; 8,848,189; 8,848,190; 8,848,191; 8,848,192; 8,848,193; 8,848,194; 8,848,195; 8,848,196; 8,848,197; 8,848,198; 8,848,199; 8,848,200; 8,848,201; 8,848,202; 8,848,203; 8,848,204; 8,848,205; 8,848,206; 8,848,207; 8,848,208; 8,848,209; 8,848,210; 8,848,211; 8,848,212; 8,848,213; 8,848,214; 8,848,215; 8,848,216; 8,848,217; 8,848,218; 8,848,219; 8,848,220; 8,848,221; 8,848,222; 8,848,223; 8,848,224; 8,848,225; 8,848,226; 8,848,227; 8,848,228; 8,848,229; 8,848,230; 8,848,231; 8,848,232; 8,848,233; 8,848,234; 8,848,235; 8,848,236; 8,848,237; 8,848,238; 8,848,239; 8,848,240; 8,848,241; 8,848,242; 8,848,243; 8,848,244; 8,848,245; 8,848,246; 8,848,247; 8,848,248; 8,848,249; 8,848,250; 8,848,251; 8,848,252; 8,848,253; 8,848,254; 8,848,255; 8,848,256; 8,848,257; 8,848,258; 8,848,259; 8,848,260; 8,848,261; 8,848,262; 8,848,263; 8,848,264; 8,848,265; 8,848,266; 8,848,267; 8,848,268; 8,848,269; 8,848,270; 8,848,271; 8,848,272; 8,848,273; 8,848,274; 8,848,275; 8,848,276; 8,848,277; 8,848,278; 8,848,279; 8,848,280; 8,848,281; 8,848,282; 8,848,283; 8,848,284; 8,848,285; 8,848,286; 8,848,287; 8,848,288; 8,848,289; 8,848,290; 8,848,291; 8,848,292; 8,848,293; 8,848,294; 8,848,295; 8,848,296; 8,848,297; 8,848,298; 8,848,299; 8,848,300; 8,848,301; 8,848,302; 8,848,303; 8,848,304; 8,848,305; 8,848,306; 8,848,307; 8,848,308; 8,848,309; 8,848,310; 8,848,311; 8,848,312; 8,848,313; 8,848,314; 8,848,315; 8,848,316; 8,848,317; 8,848,318; 8,848,319; 8,848,320; 8,848,321; 8,848,322; 8,848,323; 8,848,324; 8,848,325; 8,848,326; 8,848,327; 8,848,328; 8,848,329; 8,848,330; 8,848,331; 8,848,332; 8,848,333; 8,848,334; 8,848,335; 8,848,336; 8,848,337; 8,848,338; 8,848,339; 8,848,340; 8,848,341; 8,848,342; 8,848,343; 8,848,344; 8,848,345; 8,848,346; 8,848,347; 8,848,348; 8,848,349; 8,848,350; 8,848,351; 8,848,352; 8,848,353; 8,848,354; 8,848,355; 8,848,356; 8,848,357; 8,848,358; 8,848,359; 8,848,360; 8,848,361; 8,848,362; 8,848,363; 8,848,364; 8,848,365; 8,848,366; 8,848,367; 8,848,368; 8,848,369; 8,848,370; 8,848,371; 8,848,372; 8,848,373; 8,848,374; 8,848,375; 8,848,376; 8,848,377; 8,848,378; 8,848,379; 8,848,380; 8,848,381; 8,848,382; 8,848,383; 8,848,384; 8,848,385; 8,848,386; 8,848,387; 8,848,388; 8,848,389; 8,848,390; 8,848,391; 8,848,392; 8,848,393; 8,848,394; 8,848,395; 8,848,396; 8,848,397; 8,848,398; 8,848,399; 8,848,400; 8,848,401; 8,848,402; 8,848,403; 8,848,404; 8,848,405; 8,848,406; 8,848,407; 8,848,408; 8,848,409; 8,848,410; 8,848,411; 8,848,412; 8,848,413; 8,848,414; 8,848,415; 8,848,416; 8,848,417; 8,848,418; 8,848,419; 8,848,420; 8,848,421; 8,848,422; 8,848,423; 8,848,424; 8,848,425; 8,848,426; 8,848,427; 8,848,428; 8,848,429; 8,848,430; 8,848,431; 8,848,432; 8,848,433; 8,848,434; 8,848,435; 8,848,436; 8,848,437; 8,848,438; 8,848,439; 8,848,440; 8,848,441; 8,848,442; 8,848,443; 8,848,444; 8,848,445; 8,848,446; 8,848,447; 8,848,448; 8,848,449; 8,848,450; 8,848,451; 8,848,452; 8,848,453; 8,848,454; 8,848,455; 8,848,456; 8,848,457; 8,848,458; 8,848,459; 8,848,460; 8,848,461; 8,848,462; 8,848,463; 8,848,464; 8,848,465; 8,848,466; 8,848,467; 8,848,468; 8,848,469; 8,848,470; 8,848,471; 8,848,472; 8,848,473; 8,848,474; 8,848,475; 8,848,476; 8,848,477; 8,848,478; 8,848,479; 8,848,480; 8,848,481; 8,848,482; 8,848,483; 8,848,484; 8,848,485; 8,848,486; 8,848,487; 8,848,488; 8,848,489; 8,848,490; 8,848,491; 8,848,492; 8,848,493; 8,848,494; 8,848,495; 8,848,496; 8,848,497; 8,848,498; 8,848,499; 8,848,500; 8,848,501; 8,848,502; 8,848,503; 8,848,504; 8,848,505; 8,848,506; 8,848,507; 8,848,508; 8,848,509; 8,848,510; 8,848,511; 8,848,512; 8,848,513; 8,848,514; 8,848,515; 8,848,516; 8,848,517; 8,848,518; 8,848,519; 8,848,520; 8,848,521; 8,848,522; 8,848,523; 8,848,524; 8,848,525; 8,848,526; 8,848,527; 8,848,528; 8,848,529; 8,848,530; 8,848,531; 8,848,532; 8,848,533; 8,848,534; 8,848,535; 8,848,536; 8,848,537; 8,848,538; 8,848,539; 8,848,540; 8,848,541; 8,848,542; 8,848,543; 8,848,544; 8,848,545; 8,848,546; 8,848,547; 8,848,548; 8,848,549; 8,848,550; 8,848,551; 8,848,552; 8,848,553; 8,848,554; 8,848,555; 8,848,556; 8,848,557; 8,848,558; 8,848,559; 8,848,560; 8,848,561; 8,848,562; 8,848,563; 8,848,564; 8,848,565; 8,848,566; 8,848,567; 8,848,568; 8,848,569; 8,848,570; 8,848,571; 8,848,572; 8,848,573; 8,848,574; 8,848,575; 8,848,576; 8,848,577; 8,848,578; 8,848,579; 8,848,580; 8,848,581; 8,848,582; 8,848,583; 8,848,584; 8,848,585; 8,848,586; 8,848,587; 8,848,588; 8,848,589; 8,848,590; 8,848,591; 8,848,592; 8,848,593; 8,848,594; 8,848,595; 8,848,596; 8,848,597; 8,848,598; 8,848,599; 8,848,600; 8,848,601; 8,848,602; 8,848,603; 8,848,604; 8,848,605; 8,848,606; 8,848,607; 8,848,608; 8,848,609; 8,848,610; 8,848,611; 8,848,612; 8,848,613; 8,848,614; 8,848,615; 8,848,616; 8,848,617; 8,848,618; 8,848,619; 8,848,620; 8,848,621; 8,848,622; 8,848,623; 8,848,624; 8,848,625; 8,848,626; 8,848,627; 8,848,628; 8,848,629; 8,848,630; 8,848,631; 8,848,632; 8,848,633; 8,848,634; 8,848,635; 8,848,636; 8,848,637; 8,848,638; 8,848,639; 8,848,640; 8,848,641; 8,848,642; 8,848,643; 8,848,644; 8,848,645; 8,848,646; 8,848,647; 8,848,648; 8,848,649; 8,848,650; 8,848,651; 8,848,652; 8,848,653; 8,848,654; 8,848,655; 8,848,656; 8,848,657; 8,848,658; 8,848,659; 8,848,660; 8,848,661; 8,848,662; 8,848,663; 8,848,664; 8,848,665; 8,848,666; 8,848,667; 8,848,668; 8,848,669; 8,848,670; 8,848,671; 8,848,672; 8,848,673; 8,848,674; 8,848,675; 8,848,676; 8,848,677; 8,848,678; 8,848,679; 8,848,680; 8,848,681; 8,848,682; 8,848,683; 8,848,684; 8,848,685; 8,848,686; 8,848,687; 8,848,688; 8,848,689; 8,848,690; 8,848,691; 8,848,692; 8,848,693; 8,848,694; 8,848,695; 8,848,696; 8,848,697; 8,848,698; 8,848,699; 8,848,700; 8,848,701; 8,848,702; 8,848,703; 8,848,704; 8,848,705; 8,848,706; 8,848,707; 8,848,708; 8,848,709; 8,848,710; 8,848,711; 8,848,712; 8,848,713; 8,848,714; 8,848,715; 8,848,716; 8,848,717; 8,848,718; 8,848,719; 8,848,720; 8,848,721; 8,848,722; 8,848,723; 8,848,724; 8,848,725; 8,848,726; 8,848,727; 8,848,728; 8,848,729; 8,848,730; 8,848,731; 8,848,732; 8,848,733; 8,848,734; 8,848,735; 8,848,736; 8,848,737; 8,848,738; 8,848,739; 8,848,740; 8,848,741; 8,848,742; 8,848,743; 8,848,744; 8,848,745; 8,848,746; 8,848,747; 8,848,748; 8,848,749; 8,848,750; 8,848,751; 8,848,752; 8,848,753; 8,848,754; 8,848,755; 8,848,756; 8,848,757; 8,848,758; 8,848,759; 8,848,760; 8,848,761; 8,848,762; 8,848,763; 8,848,764; 8,848,765; 8,848,766; 8,848,767; 8,848,768; 8,848,769; 8,848,770; 8,848,771; 8,848,772; 8,848,773; 8,848,774; 8,848,775; 8,848,776; 8,848,777; 8,848,778; 8,848,779; 8,848,780; 8,848,781; 8,848,782; 8,848,783; 8,848,784; 8,848,785; 8,848,786; 8,848,787; 8,848,788; 8,848,789; 8,848,790; 8,848,791; 8,848,792; 8,848,793; 8,848,794; 8,848,795; 8,848,796; 8,848,797; 8,848,798; 8,848,799; 8,848,800; 8,848,801; 8,848,802; 8,848,803; 8,848,804; 8,848,805; 8,848,806; 8,848,807; 8,848,808; 8,848,809; 8,848,810; 8,848,811; 8,848,812; 8,848,813; 8,848,814; 8,848,815; 8,848,816; 8,848,817; 8,848,818; 8,848,819; 8,848,820; 8,848,821; 8,848,822; 8,848,823; 8,848,824; 8,848,825; 8,848,826; 8,848,827; 8,848,828; 8,848,829; 8,848,830; 8,848,831; 8,848,832; 8,848,833; 8,848,834; 8,848,835; 8,848,836; 8,848,837; 8,848,838; 8,848,839; 8,848,840; 8,848,841; 8,848,842; 8,848,843; 8,848,844; 8,848,845; 8,848,846; 8,848,847; 8,848,848; 8,848,849; 8,848,850; 8,848,851; 8,848,852; 8,848,853; 8,848,854; 8,848,855; 8,848,856; 8,848,857; 8,848,858; 8,848,859; 8,848,860; 8,848,861; 8,848,862; 8,848,863; 8,848,864; 8,848,865; 8,848,866; 8,848,867; 8,848,868; 8,848,869; 8,848,870; 8,848,871; 8,848,872; 8,848,873; 8,848,874; 8,848,875; 8,848,876; 8,848,877; 8,848,878; 8,848,879; 8,848,880; 8,848,881; 8,848,882; 8,848,883; 8,848,884; 8,848,885; 8,848,886; 8,848,887; 8,848,888; 8,848,889; 8,848,890; 8,848,891; 8,848,892; 8,848,893; 8,848,894; 8,848,895; 8,848,896; 8,848,897; 8,848,898; 8,848,899; 8,848,900; 8,848,901; 8,848,902; 8,848,903; 8,848,904; 8,848,905; 8,848,906; 8,848,907; 8,848,908; 8,848,909; 8,848,910; 8,848,911; 8,848,912; 8,848,913; 8,848,914; 8,848,915; 8,848,916; 8,848,917; 8,848,918; 8,848,919; 8,848,920; 8,848,921; 8,848,922; 8,848,923; 8,848,924; 8,848,925; 8,848,926; 8,848,927; 8,848,928; 8,848,929; 8,848,930; 8,848,931; 8,848,932; 8,848,933; 8,848,934; 8,848,935; 8,848,936; 8,8



CONTECH[®]
ENGINEERED SOLUTIONS

The Stormwater Management StormFilter[®]

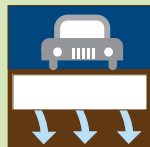
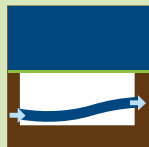

Solutions
Guide

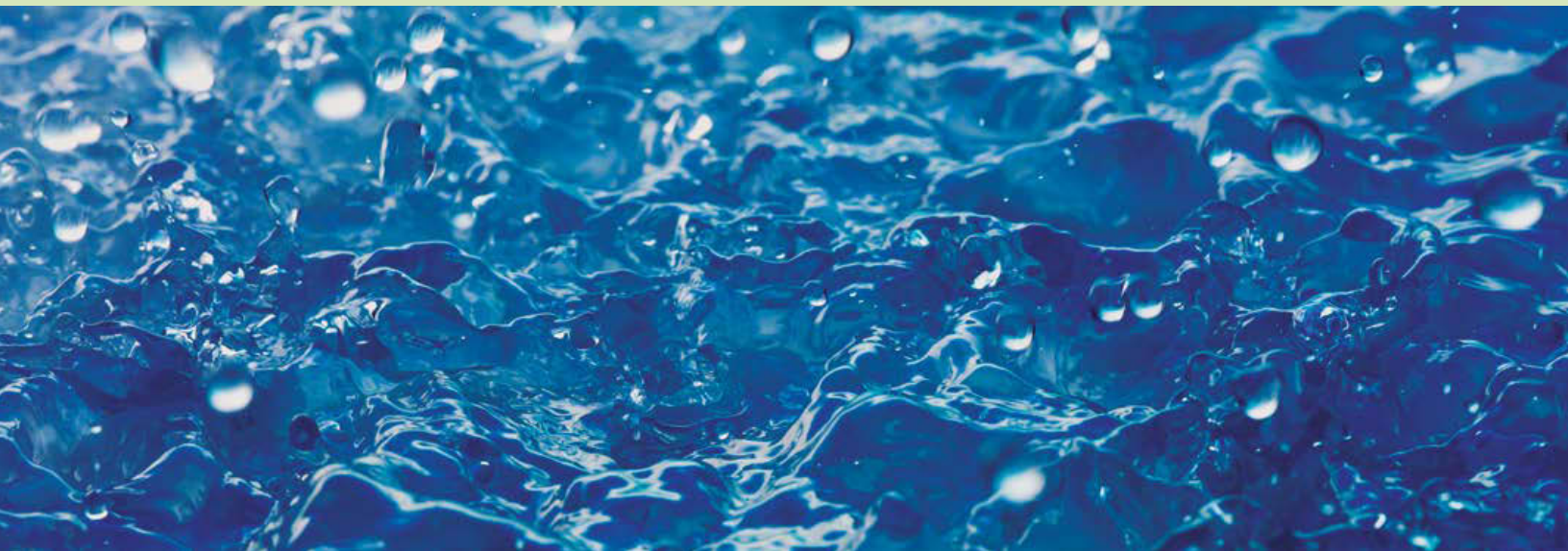

Stormwater Filtration



Selecting the right stormwater solution just got easier...

It's simple to choose the right low impact development (LID) solution to achieve your runoff reduction goals with the Contech UrbanGreen® Staircase. First, select the runoff reduction practices that are most appropriate for your site, paying particular attention to pretreatment needs. If the entire design storm cannot be retained, select a treatment best management practice (BMP) for the balance. Finally, select a detention system to address any outstanding downstream erosion.

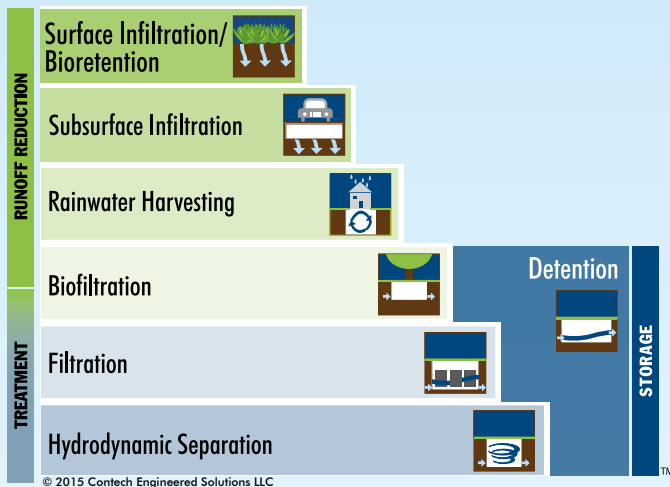

Highly Effective Pollutant Removal

Stormwater quality standards are becoming increasingly complex, especially with the advent of total maximum daily load (TMDL) requirements. Meeting pollutant reduction goals typically requires a technology that is highly effective at removing solids and associated pollutants from stormwater. In some cases, the technology must also be capable of removing dissolved pollutants such as metals and phosphorus. Using a variety of media, filtration systems can meet that need.

For almost two decades the Stormwater Management StormFilter® has helped you meet the most stringent stormwater requirements. The system has been continually tested and refined to ensure maximum reliability and performance.

Learn more about filtration at www.ContechES.com/stormfilter



The Stormwater Management StormFilter helps you meet the most stringent stormwater requirements ❖❖❖

Choosing the Right System

The Fundamentals of Filtration

The performance and longevity of media filtration systems is governed by a number of variables that must be carefully considered when evaluating systems, including media type, media gradation, hydraulic loading rate. Understanding these variables requires careful testing and development of performance and longevity data to support proper filter design.

Media Surface Area

Filtration flow rates are typically expressed as a surface area specific operating rate such as gallons per minute per square foot (gpm/ft²) of surface area. Lower specific operating rates translate to better performance and longer maintenance cycles. Specific operating rates higher than 2 gpm/ft² of media surface area negatively impact performance and longevity.

Surface vs. Radial Cartridge Filtration

When assessing filtration systems, it is important to consider whether filtration occurs primarily at the media surface or throughout a bed of media like in radial-cartridge filters. All else equal, radial-cartridge filters are longer lasting, since pollutants are captured and stored throughout the bed, as opposed to predominantly on the media surface. Radial cartridge filters capture more mass of pollutants per unit area of filter surface. Surface filters, such as membranes, are prone to rapid failure due to clogging, as pollutants occlude the media surface which requires frequent backwashing.

Media Hydraulic Conductivity and Flow Control

Filtration media is able to pass more flow per unit of media when it is new versus when it has been in operation for a while. With time, pollutants accumulate in the media bed and reduce its hydraulic capacity. It is critical that filtration devices are designed with excess hydraulic capacity to account for this loss. Also, finer media gradations remove finer particles, but have lower hydraulic capacity and occlude more rapidly. High performance and superior longevity can be achieved by controlling the flow through a more coarse media bed.

Performance: Laboratory Testing

Laboratory testing provides a means to generate hydraulic and basic performance data, but should be complimented with long-term field data. Laboratory performance trials should be executed with a fine sediment gradation such as Sil-Co-Sil 106 which has a median particle size of 22 microns. Testing with coarser gradations is not likely to be representative of field conditions.

Performance: Field Testing

Long-term field evaluations should be conducted on all filtration devices. Field studies should comply with the Technology Acceptance Reciprocity Partnership (TARP), Environmental Technology Verification (ETV) or the Technology Assessment Protocol – Ecology (TAPE) protocols. Testing should be overseen by a reputable third-party to be considered valid.

Longevity

It is essential that loading trials be conducted to evaluate the longevity of a media filter. These trials must be executed with “real” stormwater solids and not silica particles. Reliance on silica particles to assess longevity grossly overstates the loading capacity of the media and the results of such trials should not be relied on. Knowing how much mass a media filter can capture before failure allows it to be sized for a desired maintenance interval by estimating the pollutant load that will be delivered to the filter.



The Stormwater Management StormFilter®

A best management practice (BMP) designed to meet stringent regulatory requirements; the Stormwater Management StormFilter removes the most challenging target pollutants – including fine solids, soluble heavy metals, oil, and total nutrients – using a variety of media. For more than two decades, StormFilter has helped clients meet their regulatory needs and through product enhancements the design continues to be refined for ease of use.

Here's Why StormFilter is the Best Filter Available:

Superior Hydraulics

- External bypass – Protects treatment chamber from high flows and ensures captured pollutants are not lost during low frequency, high intensity storm events
- Multiple cartridge heights – Minimize head loss to fit within the hydraulic grade line and shrink system size, reducing install costs
- Over 30 StormFilter configurations in use across the country

Reliable Longevity

- Unique surface-cleaning mechanism – Prevents surface blinding, ensures use of all media, and prolongs cartridge life
- One to two-year maintenance cycles - Fewer maintenance events compared to similar products reduces costs over the lifetime of the system
- 15-years of maintenance experience – Predictable long-term performance comes standard

Proven Performance

- Only proven filter on the market - Performance verified by the WA Ecology and NJ DEP, and system approved for use with numerous local agencies
 - Qualifies for LEED® Sustainable Site Credit 6.2 – Stormwater Quality Control
- Achieve water quality goals with confidence – Easy approval speeds permitting
- 8th Generation Product – Design refined and perfected over two decades of research and experience
- Full-scale testing at more than 10 sites around the United States

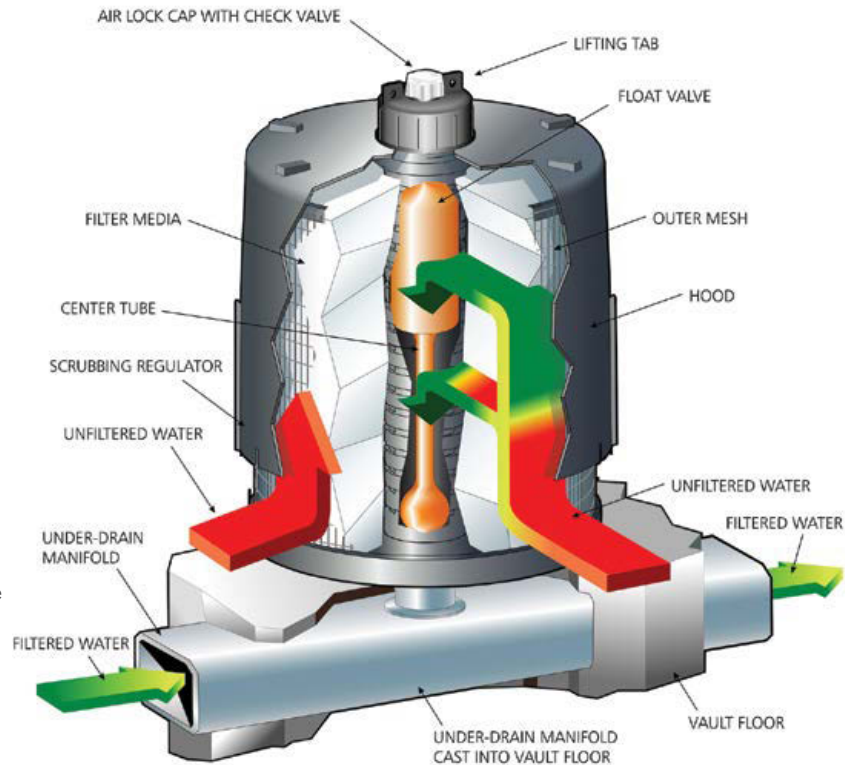

Underground System Maximizes Land Use and Development Profitability

- Save land space, allow denser development and reduce sprawl
- Add parking, increase building size, develop outparcels by eliminating aboveground systems
- Compact design reduces construction and installation costs by limiting excavation

Patented Siphon-Actuated Filtration

During a storm, runoff passes through the filtration media and starts filling the cartridge center tube. Air below the hood is purged through a one-way check valve as the water rises. When water reaches the top of the float, buoyant forces pull the float free and allow filtered water to drain.

After the storm, the water level in the structure starts falling. A hanging water column remains under the cartridge hood until the water level reaches the scrubbing regulators at the bottom of the hood. Air then rushes through the regulators releasing water and creating air bubbles that agitate the surface of the filter media, causing accumulated sediment to drop to the vault floor. This patented surface-cleaning mechanism helps restore the filter's permeability between storm events.

See the StormFilter in action at www.ContechES.com/stormfilter



Unique surface-cleaning mechanism prevents surface blinding, ensures use of all media, and prolongs cartridge life



For even more information, check out the StormFilter Animation available at www.conteches.com/videos

Configurations and Applications

The StormFilter technology can be configured to meet your unique site requirements. Here are a few of the most common configurations, however many other configurations are available. Please contact your Contech Project Consultant to evaluate the best options for your site or find out more in the [StormFilter Configuration Guide available on www.ContechES.com/stormfilter](http://www.ContechES.com/stormfilter).

Upstream Treatment Configurations

The following suite of StormFilter configurations are easily incorporated on sites where LID site design is recommended. These low-cost, low-drop, point-of-entry systems also work well when you have a compact drainage area.



CatchBasin StormFilter

- Combines a catch basin, a high flow bypass device, and a StormFilter cartridge in one shallow structure
- Treats sheet flow
- Uses drop from the inlet grate to the conveyance pipe to drive the passive filtration cartridge
- No confined space required for maintenance

CatchBasin StormFilter



Curb Inlet

- Accommodates curb inlet openings from 3 to 10 feet long
- Uses drop from the curb inlet to the conveyance pipe to drive the passive filtration cartridges

Curb Inlet



Linear Grate

- Can be designed to meet volume based sizing requirements
- Can be installed in place of and similar to a typical catch basin
- No confined space entry required for maintenance
- Accommodates up to 29 StormFilter cartridges

Linear Grate

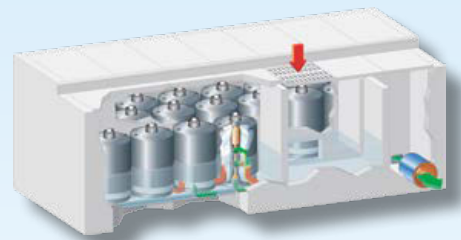

Infiltration/Retrofit Configuration

Infiltration

- Provides treatment and infiltration in one structure
- Available for new construction and retrofit applications
- Easy installation



Infiltration

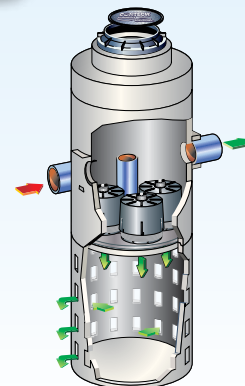

Roof Runoff Treatment Configuration



DownSpout

- Easily integrated into existing gutter systems to treat pollution from rooftop runoff
- Fits most downspout configurations and sizes; single or dual-cartridge models available
- Treats up to 14,000 square feet of rooftop area per dual-cartridge system

DownSpout StormFilter



Downstream Treatment Configurations

Conventional stormwater treatment involves collecting, conveying and treating stormwater runoff with an end of pipe treatment system before discharging off-site. StormFilter configurations suitable for these applications are listed below and can be engineered to treat a wide range of flows.

Vault / Manhole

- Treats small to medium sized sites
- Simple installation - arrives on-site fully assembled
- May require off-line bypass structure

Vault

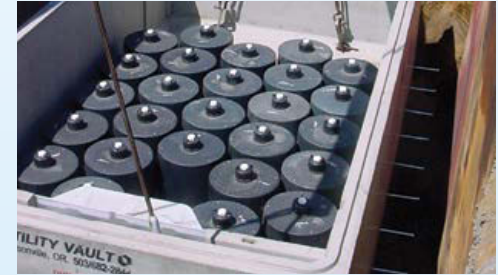

High Flow

- Treats flows from large sites
- Consists of large, precast components designed for easy assembly on-site
- Several configurations available, including: CON/SPAN®, Panel Vault, Box Culvert, or Cast-In-Place

High Flow



Volume

- Meets volume-based stormwater treatment regulations
- Captures and treats specific water quality volume (WQv)
- Provides treatment and controls the discharge rate
- Can be designed to capture all, or a portion, of the WQv

Manhole



Peak Diversion

- Provides off-line bypass and treatment in one structure
- Eliminates material and installation cost of additional structures to bypass peak flows
- Reduces the overall footprint of the treatment system, avoiding utility and right-of-way conflicts
- Internal weir allows high peak flows with low hydraulic head losses
- Accommodates large inlet and outlet pipes (up to 36") for high flow applications

Peak Diversion

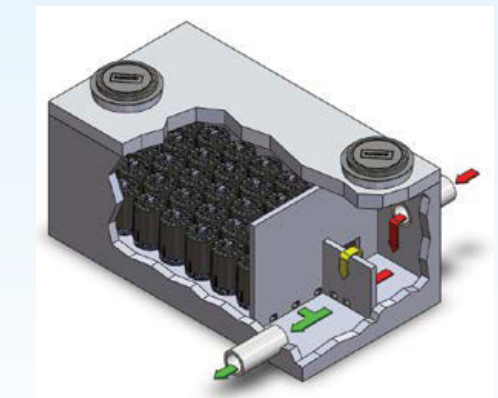

Media Options

Our filtration products can be customized using different filter media to target site-specific pollutants. A combination of media is often recommended to maximize pollutant removal effectiveness.



PhosphoSorb® is a lightweight media built from a Perlite-base that removes total phosphorus (TP) by adsorbing dissolved-P and filtering particulate-P simultaneously.



Perlite is naturally occurring puffed volcanic ash. Effective for removing TSS, oil and grease.



CSF® Leaf Media and **MetalRx™** are created from deciduous leaves processed into granular, organic media. CSF is most effective for removing soluble metals, TSS, oil and grease, and buffering acid rain. MetalRx, a finer gradation, is used for higher levels of metal removal.



Zeolite is a naturally occurring mineral used to remove soluble metals, ammonium and some organics.



GAC (Granular Activated Carbon) has a micro-porous structure with an extensive surface area to provide high levels of adsorption. It is primarily used to remove oil and grease and organics such as PAHs and phthalates.

	PhosphoSorb	Perlite	CSF	MetalRx	Zeolite	GAC
Sediments	•	•	•			
Oil and Grease	•	•	•	•		
Soluble Metals	•		•	•	•	
Organics			•	•		•
Nutrients	•	•	•	•	•	
Total Phosphorus	•					

Note: Indicated media are most effective for associated pollutant type. Other media may treat pollutants, but to a lesser degree.

ZPG™ media, a proprietary blend of zeolite, perlite, and GAC, is also available and provides an alternative where leaf media cannot be used.

Focus on Phosphorous

Stormwater runoff with elevated phosphorus concentration can significantly impair water quality. More stringent stormwater regulations calling for higher levels of phosphorus removal are currently being implemented. To meet these requirements, more than just the physical separation of particulate P is needed. That's where the PhosphoSorb media can help.

A cost-effective, lightweight, adsorptive filtration media, PhosphoSorb offers the effective adsorption capacity of dissolved phosphorus and retention capacity of particulate phosphorus. Initial field results suggest removal of greater than 65% of the total phosphorus load can be expected when influent concentrations exceed 0.1 mg/l, and the media can remain in operation for more than 1 year without requiring maintenance due to media occlusion.

Dissolved Phosphorus

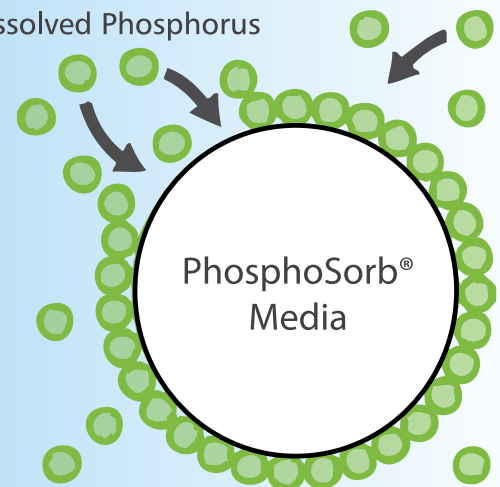

Cartridge Options

With multiple cartridge heights available, you have a choice when fitting a StormFilter system onto your site.

The 27" cartridge provides 50% more treatment per square foot of system than the 18" cartridge. So, you are meeting the same treatment standards with fewer cartridges, which means a smaller system.

If you are limited by hydraulic constraints, choose our low drop cartridge, which provide filtration treatment with only 1.8 feet of headloss.

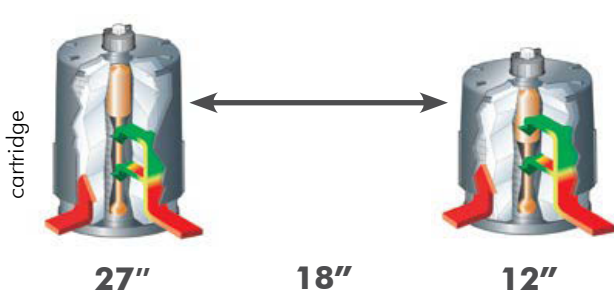

Cartridge Flow Rates

Cartridge Type	Hydraulic Drop	Treatment Capacity (gpm)	
		1 gpm/ft ²	2 gpm/ft ²
StormFilter 27"	3.05 feet	11.25	22.5
StormFilter 18"	2.3 feet	7.5	15
StormFilter Low Drop	1.8 feet	5	10
MFS 22"	2.3 feet	9	18
MFS 12"	1.4 feet	5	10

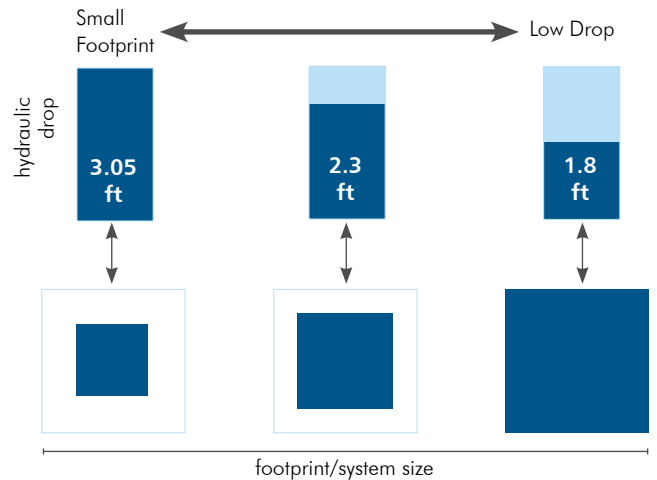

Multiple cartridge heights are available to meet your hydraulics needs ❖❖❖

StormFilter Accessories

Drain-Down

- Provides complete dewatering of the StormFilter vault by gradually removing residual water in the sump after the storm event
- Aids in vector control by eliminating mosquito-breeding habitat
- Eliminates putrefaction and leaching of collected pollutants
- Lowers maintenance cost by reducing decanting and disposal volume

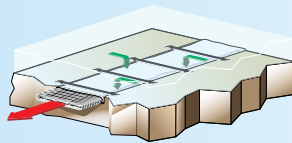

Sorbent Hood Cover

- Absorbs free surface oil and grease on contact
- Will not release captured oil, even when saturated
- Made from recycled synthetic fiber

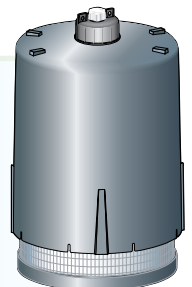

Cartridge Lifting Hook

- Specially designed to help you easily lift cartridges during maintenance



Maintenance

Longevity is a function of applying existing filtration physics to the maximum extent possible in order to decrease maintenance frequency without sacrificing performance. Maintenance is an integral part of ensuring long term effectiveness of a filter system. The quality of treatment can only be guaranteed by a well maintained structure, whether it is proprietary or nonproprietary. The notion that some BMPs, including low impact development (LID) structures, have no maintenance cost burden is a misconception.

Longer Maintenance Intervals Reduce Life Cycle Costs

Maintenance intervals can be a large unseen cost for developers and owners. Including a maintenance interval in the product specification will ensure that no one is surprised with high long term costs.

The Stormwater Management StormFilter can be designed with up to a 2 year maintenance interval, proven by over a decade of installations, which can greatly reduce costs. Our filter cartridges are made with 60% of recyclable material.

Ease of Maintenance Matters

The StormFilter has been optimized over time to make maintenance easy. Cartridges feature a 1/4 turn connector, so they can be quickly removed and installed. A removable hood allows for effortless access to spent media, especially compared to sealed systems that require cutting the cartridge hood. Finally, all StormFilter structures can be accessed without restriction for inspection, media replacement, and washing of structure.

Experience Counts

Contech has over 120,000 StormFilter cartridges in use throughout the country. We have a plant dedicated to the production of filtration cartridges based in Portland, OR, that supports maintenance events with exchange of full cartridge and maintenance contracts. All cartridge components go through a QA/QC review at the refilling point to ensure that the correct media gradation is supplied and that it is packed properly which provides reliable operation and performance.

Not All Stormwater Filtration Systems are the Same

When you choose the Stormwater Management StormFilter, you are choosing the industry leading technology. Our experienced design engineers can help you design the system that will work for your site and your budget.

Maintenance Required If:



Greater than 4" of sediment is on the structure floor



Greater than 1/4" of sediment is on the top of the cartridges



Greater than 4" of standing water in vault for more than 24 hours after a storm

Annual StormFilter vault inspection is recommended and it doesn't require confined space entry ❖❖❖



Pollutants must be removed to restore the StormFilter to its full efficiency and effectiveness.

Spent filter media can be dumped directly onto the structure floor, so the emptied lightweight cartridges can be easily removed, thus eliminating the need for handling heavy units.



Easy to access treatment system can make a difference in maintenance expenses.



StormFilter structures can be accessed without confined space for inspection.

The quality of treatment can only be guaranteed by a well maintained structure





LEARN MORE

- Access project profiles, photos, videos and more online at www.ContechES.com/stormfilter

CONNECT WITH US

- Call us at 800-338-1122
- Contact your local rep at www.ContechES.com/localresources

START A PROJECT

- Submit your system requirements on our product Design Worksheet www.ContechES.com/start-a-project

USE OUR ONLINE TOOLS

- Low Impact Development Site Planner www.ContechES.com/LIDsiteplanner



COMPLETE SITE SOLUTIONS

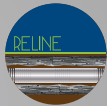
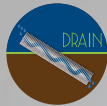

TREATMENT SOLUTIONS

Helping to satisfy stormwater management requirements on land development projects

- Stormwater Treatment
- Detention/Infiltration
- Rainwater Harvesting
- Biofiltration/Bioretenation

PIPE SOLUTIONS

Meeting project needs for durability, hydraulics, corrosion resistance, and stiffness

- Corrugated Metal Pipe (CMP)
- Steel Reinforced Polyethylene (SRPE)
- High Density Polyethylene (HDPE)
- Polyvinyl Chloride (PVC)

STRUCTURES SOLUTIONS

Providing innovative options and support for crossings, culverts, and bridges

- Plate, Precast & Truss bridges
- Hard Armor
- Retaining Walls
- Tunnel Liner Plate



©2017 Contech Engineered Solutions LLC, a QUIKRETE Company
800-338-1122
www.ContechES.com

All Rights Reserved. Printed in the USA.

Contech Engineered Solutions LLC provides site solutions for the civil engineering industry. Contech's portfolio includes bridges, drainage, sanitary sewer, stormwater and earth stabilization products. For information on other Contech division offerings, visit ContechES.com or call 800.338.1122

The product(s) described may be protected by one or more of the following US patents: 5,707,527; 5,788,848; 5,985,157; 6,027,639; 6,350,374; 6,406,218; 6,641,720; 6,511,595; 6,649,048; 6,991,114; 6,998,038; 7,186,058; 7,296,692; 7,297,266 related foreign patents or other patents pending.

The Stormwater Management StormFilter, MFS and CDS are trademarks, registered trademarks, or licensed trademarks of Contech Engineered Solutions LLC. LEED is a registered trademark of the U.S. Green Building Council.

Get Social With Us!



NOTHING IN THIS CATALOG SHOULD BE CONSTRUED AS A WARRANTY. APPLICATIONS SUGGESTED HEREIN ARE DESCRIBED ONLY TO HELP READERS MAKE THEIR OWN EVALUATIONS AND DECISIONS, AND ARE NEITHER GUARANTEES NOR WARRANTIES OF SUITABILITY FOR ANY APPLICATION. CONTECH MAKES NO WARRANTY WHATSOEVER, EXPRESS OR IMPLIED, RELATED TO THE APPLICATIONS, MATERIALS, COATINGS, OR PRODUCTS DISCUSSED HEREIN. ALL IMPLIED WARRANTIES OF MERCHANTABILITY AND ALL IMPLIED WARRANTIES OF FITNESS FOR ANY PARTICULAR PURPOSE ARE DISCLAIMED BY CONTECH. SEE CONTECH'S CONDITIONS OF SALE (AVAILABLE AT WWW.CONTECHES.COM/COS) FOR MORE INFORMATION.

StormFilter Configuration Guide



The Stormwater Management StormFilter®

The Stormwater Management StormFilter (StormFilter) is a passive, flow-through, stormwater filtration system. The system is comprised of one or more structures that house rechargeable, media-filled cartridges which trap particulates and adsorb materials such as dissolved metals, hydrocarbons, and nutrients in polluted runoff.

The StormFilter system comes in a variety of configurations and sizes to meet any site need. A variety of filter media is available and can be customized for each site to remove the desired pollutants.

Basic Design

The StormFilter is sized to treat the peak flow of a water quality design storm. The peak flow or WQv is determined from calculations based on the contributing watershed hydrology and from a design storm magnitude set by the local stormwater management agency. The StormFilter system is modular and each unit is designed with the number of cartridges required to meet the peak design flow rate, WQv or cap.

The flow rate through each filter cartridge is set to meet the jurisdictional performance requirements, allowing control over the amount of contact time between the influent and the filter media. The maximum flow rate through each cartridge can be adjusted, between 0.26 gpm/ft² and 2 gpm/ft² of surface area, using a calibrated restrictor disc at the base of each filter cartridge. Adjustments to the cartridge flow rate will affect the number of cartridges required to treat the peak flow or WQv.

Please contact your local Contech representative for site-specific design assistance.

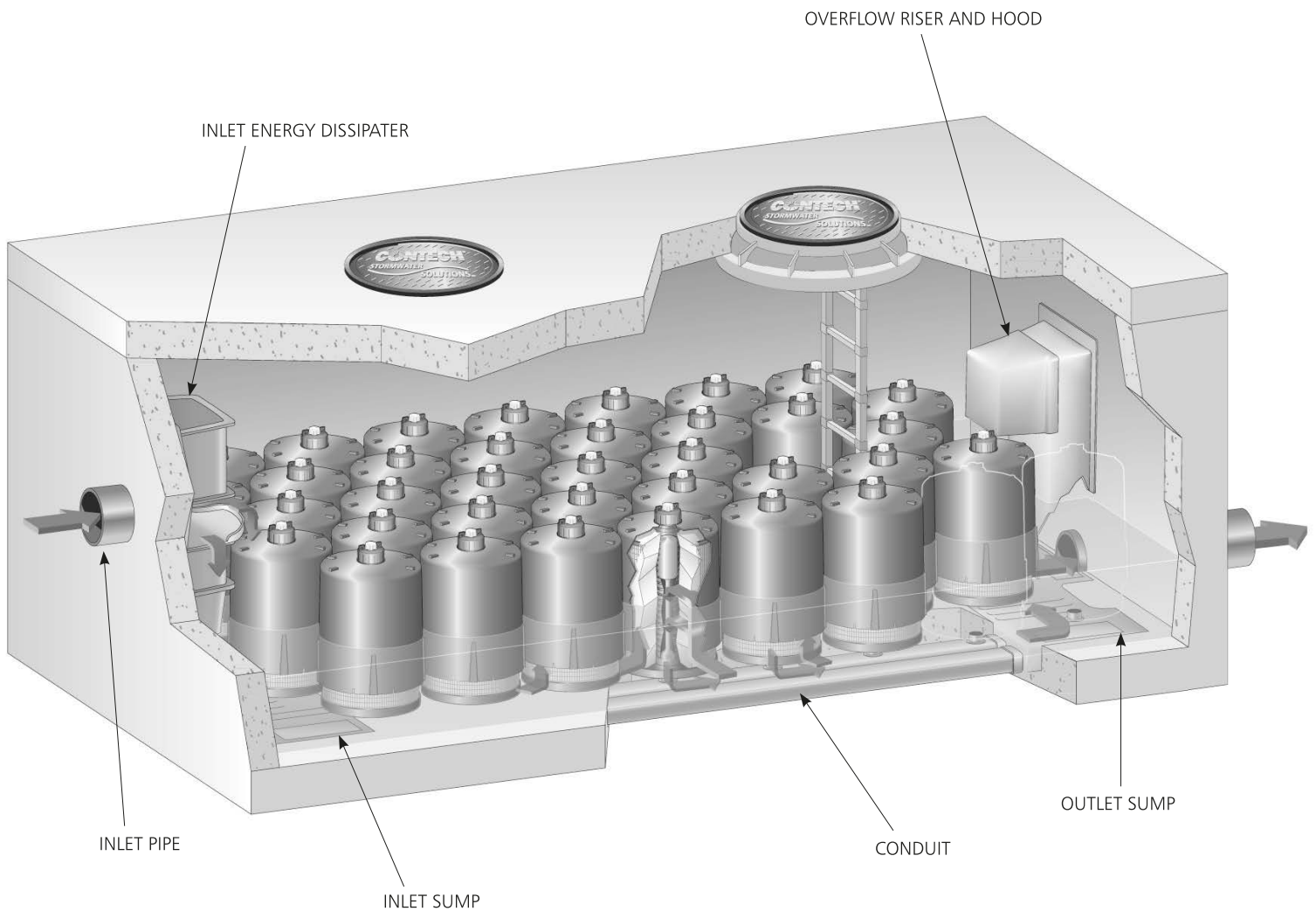

Basic Operation

Priming System Function

The system is designed to siphon stormwater runoff through the StormFilter cartridge. Stormwater enters a StormFilter cartridge, percolates horizontally through the cartridge's filter media and collects in the center tube where the float valve is in a closed (downward) position.

As water passes through the filter media and into the cartridge's center tube, the air in the cartridge is displaced by the water and purged from beneath the filter hood through the one-way check valve located in the cap. Once the center tube is filled with water, there is enough buoyant force to open the float valve and allow the treated water in the center tube to flow into the under-drain manifold. This causes the check valve to close, initiating a siphon that draws polluted water throughout the full surface area and volume of the filter. Thus, the entire filter cartridge is used to filter water throughout the duration of the storm, regardless of the water surface elevation in the unit. This siphon continues until the water surface elevation drops to the elevation of the hood's scrubbing regulators, and the float returns to a closed position. Utilizing the hydraulic potential in the cartridge, the scrubbing regulators cause the filter surface to be clean of attached sediments thus extending the filter's operational life.

Flow and Valve Control

The filtration rate through a typical StormFilter cartridge can be adjusted so that it has a maximum flow rate of 2 gpm/ft² at

the design driving head. The flow rate is individually controlled for each cartridge by a restrictor disc located at the connection point between the cartridge and the under-drain manifold. Consisting of a simple orifice disc of a specific diameter, the flow rate through the cartridges can be adjusted to a level that coincides with your treatment requirements by using a disc with the appropriate orifice diameter.

A reduction in flow rate affects the performance of the StormFilter system with regards to both sediment and soluble pollutants. For solids, Stokes' Law predicts the movement of sediment in a fluid and it has been proven that a reduction in the flow velocity through the system will facilitate increased settling and capture of sediments. In addition, some media types have the ability to remove soluble pollutants through chemical processes, like ion exchange. A reduction in the flow velocity through the StormFilter cartridge will increase the contact time between the stormwater and the media, thereby increasing the removal efficiency by increasing the time for a chemical process to take place.

Media type can be changed, but flow rate adjustment requires engineering consultation to ensure hydraulic demands are satisfied.

Through routine maintenance, a media filtration system can adjust the media type to target or update the system to treating specific pollutants, new TMDLs, or changing pollutants of concern. The media change out can provide a long-term solution to changing regulatory requirements.

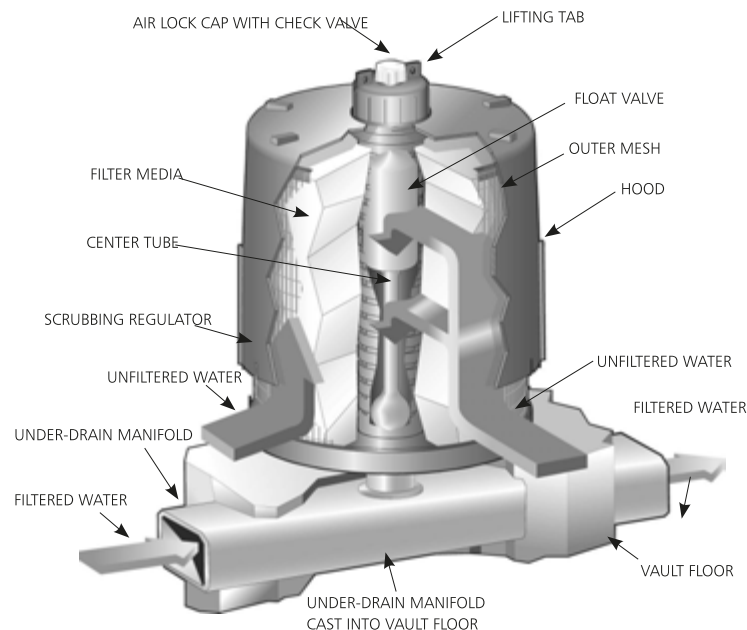

StormFilter Configurations

The StormFilter technology can be configured to meet your unique site requirements.

Downstream Treatment Configurations

Conventional stormwater treatment involves collecting, conveying and treating stormwater runoff with an end of pipe treatment system before discharging off-site. StormFilter configurations suitable for these applications are listed below and can be engineered to treat a wide range of flows.

Vault/Manhole

The Vault/Manhole consists of one or more precast concrete structures ranging from 48" manholes to 8' x 24' vaults. The largest unit treats water quality design flows up to 3.75 cfs, and can be placed in series or in parallel to treat higher flows if needed.

A Vault/Manhole configuration can be installed online or offline from storm system, where the unit has internal overflow bypass. These systems can also be installed offline, where high flows are bypassed around the treatment system and there is no internal overflow. However, if detention, pretreatment, or bypassing is required, it can be installed offline of the storm system.

Basic Operation

Vault/Manhole systems are housed in either a vault or manhole. Stormwater first enters the structure through the inlet pipe where it is directed through the energy dissipator. This gently spreads the flow to minimize re-suspension of previously captured pollutants.

Once in the filtration area, the stormwater begins to pond and percolate horizontally through the media contained in the filter cartridges. After passing through the media, treated water that has collected in the cartridge center tube is directed into the outlet sump by an under-drain manifold. The treated water in the outlet sump is then discharged through the outlet pipe.

Precast StormFilter systems have an internal bypass capability from 1.0 cfs to 2.0 cfs, depending upon the size of the system. If peak flows to the system exceed 2.0 cfs, an offline high flow bypass is needed.

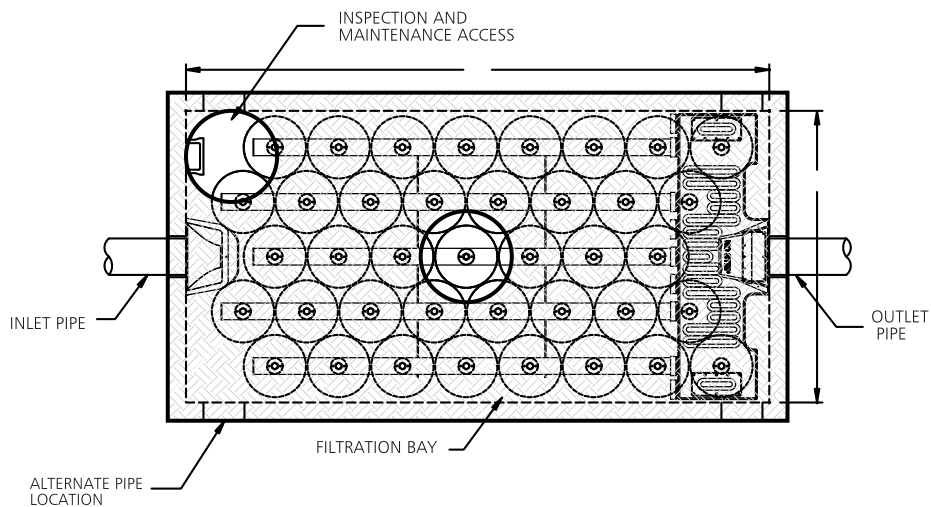
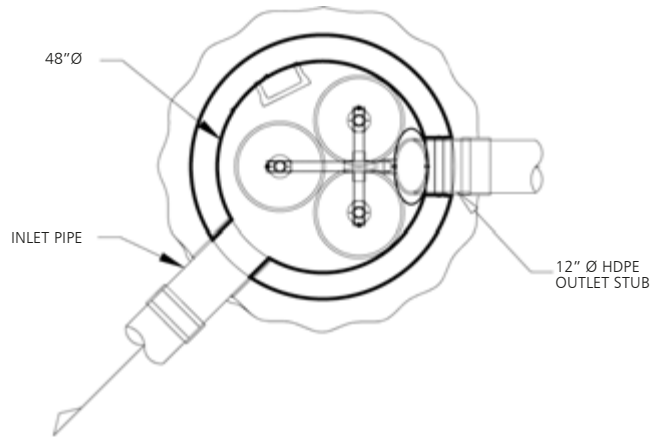

Vault/Manhole StormFilter

High Flow StormFilter

High Flow StormFilter systems can be designed within a variety of structures to meet local requirements and streamline installation. These systems are designed for large sites and large flows. Too big for standard precast structures, they are usually built from precast components that are assembled on site. The High Flow StormFilter is available in several configurations: CON/SPAN®, Panel Vaults, Box Culverts, or Cast-In-Place.

Basic Operation

The High Flow StormFilter design has the same basic configuration and components as the Precast StormFilter but operates on a larger scale.

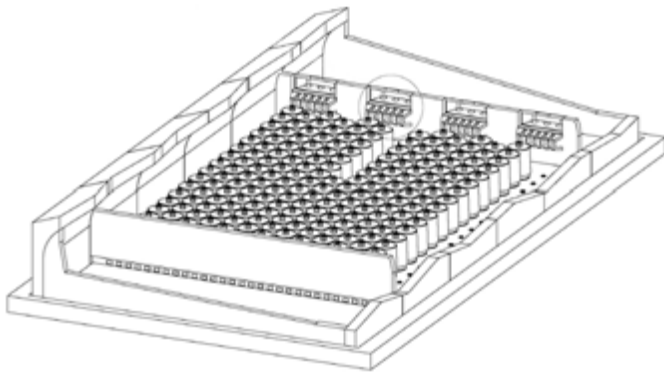

High Flow StormFilter

Peak Diversion StormFilter

The Peak Diversion StormFilter includes a treatment chamber and offline by-pass capability in one precast vault. Sizes range from 8'x11" to 8'x24" in most areas. Larger units can treat up to 2.5 cfs depending on cartridge height and the approved flow rate of regulatory jurisdiction. The integrated off-line bypass eliminates upstream flow splitters, downstream junction structures, and additional piping to save space and reduce the overall foot print. This lowers materials and installation cost while reducing potential conflicts with right of way (ROW) boundaries and utilities.

Basic Operation

Stormwater enters the structure through one or two inlet pipes into the inlet bay and low flows are directed to the filtration bay through a transfer opening. Once in the filtration area, the stormwater begins to pond and percolate horizontally through the media contained in the filter cartridges. After passing through the media, treated water that has collected in the cartridge center tube is directed into the outlet bay by an under-drain manifold. The treated water in the outlet sump is then discharged through the outlet pipe.

During large storm events greater than the treatment capacity, peak flows are diverted across the overflow weir directly to the outlet. Even during high flows the cartridges are still operating and water is entering the filtration bay from the inlet bay. This continuous flow into the filter bay helps ensure pollutants can not be washed out during high flow events.

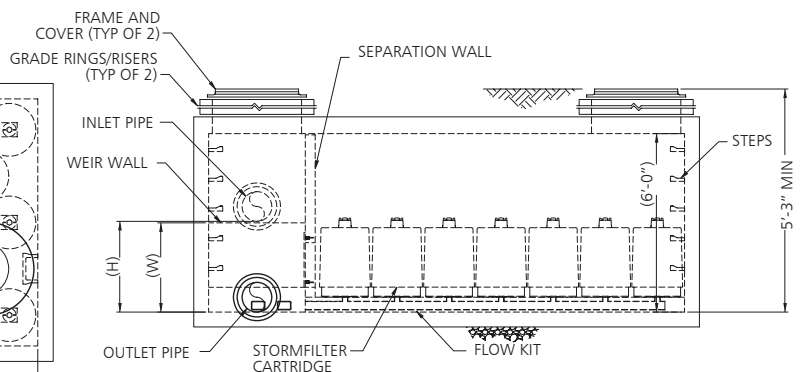
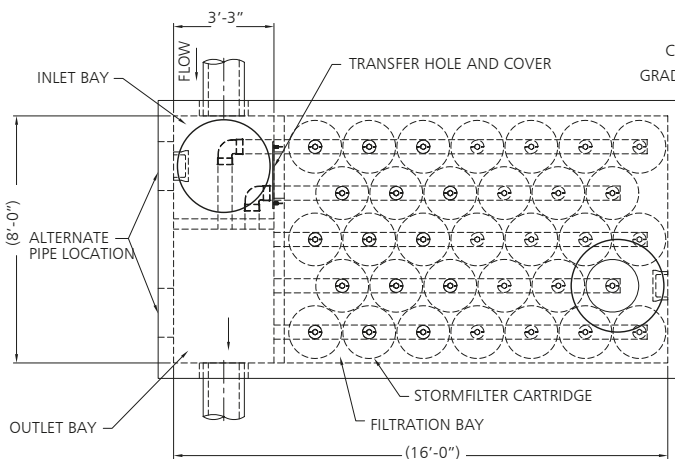

Peak Diversion StormFilter

Volume StormFilter

The Volume StormFilter is designed to meet volume-based regulations where a specific water quality volume (WQv) must be captured and treated. In addition to the treatment, the structure can be sized to capture all or a portion of the WQv.

Restrictor discs inside each cartridge can be used to control the discharge rate from the system. The size of the disc is calibrated to provide the design filtration rate at a live storage depth. Because of these discs (and the airlock cap with a one way vent) water can be impounded above the cartridges in the treatment bay.

Structures range in size from a 48" manhole to CON/SPAN sections with a 24' x 10' cross section built to length. In many cases smaller structures are combined with outboard storage, such as pipe, to provide the WQv storage.

The Volume StormFilter can be designed with or without an internal bypass. If peak flows to the system exceed the internal bypass, or external bypass. If peak flows to the system exceed the internal bypass, or external bypass is required, a high flow bypass is needed. The system can also be installed online or offline and uses a traffic-bearing lid.

Basic Operation

The Volume StormFilter is typically configured in one of two ways.

A three bay system that incorporates internal storage for the WQv and includes: the storage bay, the filtration bay, and the outlet bay. Water first enters the storage bay (a portion of which includes dead storage) which facilitates pretreatment (gravity separation) and storage of the WQv. The stormwater is then directed into the filtration bay for full treatment and additional storage. The storage bay can be designed with a baffle to trap floatables, oils, and surface scum. Cartridges in the filtration bay treat the stormwater and control the discharge rate. Once in the filtration bay, the stormwater percolates horizontally through the media contained in the filter cartridges. After passing through the cartridge, treated water is directed to the outlet bay by an under-drain manifold where it is discharged through an outlet pipe.

A two bay, precast vault bases system similar to the Vault StormFilter where pretreatment and live storage are provided upstream.

Providing WQv storage in an outboard storage facility such as storage pipe provides the versatility to meet most footprint and elevation requirements.

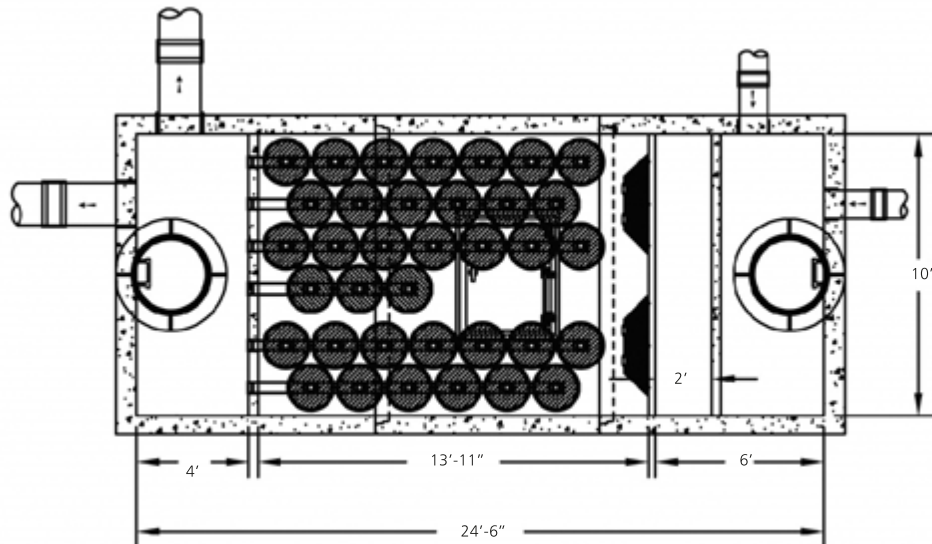

Volume StormFilter

Upstream Treatment Configurations

Low Impact Design (LID) involves managing runoff close to the source using small, decentralized system. The following suite of StormFilter configurations are easily incorporated on sites where LID site design is recommended. These low-cost, lowdrop, point-of-entry systems also work well when you have a compact drainage area.

CatchBasin StormFilter

The CatchBasin StormFilter (CBSF) consists of a multi-chamber steel, concrete, or plastic catch basin unit that contains up to four StormFilter cartridges. The steel CBSF is offered both as a standard and as a deep unit.

The CBSF is installed flush with the finished grade and is applicable for small drainage areas from roadways and parking lots, and retrofit applications. It can also be fitted with an inlet pipe for roof leaders or similar applications.

The CBSF unit treats water quality design flows up to 0.20 cfs, coupled with an internal weir overflow capacity of 1.0 cfs for the standard steel and concrete units and 1.8 cfs for the deep steel units. Non-traffic rated plastic CBSF units have an internal weir overflow capacity of 0.5 cfs.

Basic Operation

The CBSF acts as the primary receiver of runoff, similar to a standard, grated catch basin. The steel and concrete CBSF units each have an H-20 rated, traffic-bearing lid that allows the filter to be installed in parking lots and take up no land area. Plastic CBSF units can be used in landscaped areas and for other non-traffic bearing applications.

The CBSF consists of a sumped inlet chamber and cartridge chamber(s). Runoff enters the sumped inlet chamber either by sheet flow from a paved surface or from an inlet pipe discharging directly to the unit. The inlet chamber's internal baffle traps debris and floating oil, and houses an overflow weir. Heavier solids settle into the deep sump, while lighter solids and soluble pollutants are directed under the baffle and into the cartridge chamber through a port between the baffle and the overflow weir. Once in the cartridge chamber, polluted water ponds and percolates horizontally through the media in the filter cartridges. Treated water collects in the cartridge's center tube from where it is directed by an under-drain manifold to the outlet pipe on the downstream side of the overflow weir and discharged.

When flows into the CBSF exceed the water quality design value, excess water spills over the overflow weir, bypassing the cartridge bay, and discharges to the outlet pipe.

The CBSF is particularly useful where small flows are being treated or for sites that are flat and have little available hydraulic head to spare. The unit is ideal for applications in which standard catch basins are to be used. Both water quality and catchment issues can be resolved with the use of the CBSF.

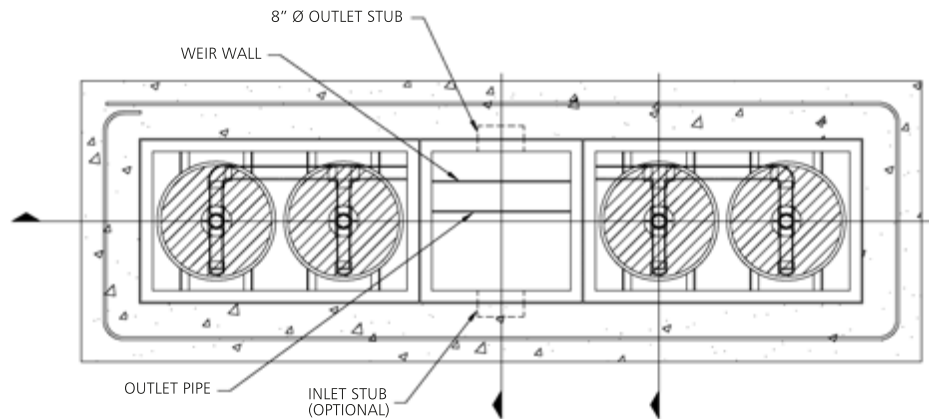

CatchBasin StormFilter

Curb Inlet StormFilter

The Curb Inlet StormFilter consists of a precast concrete vault ranging from 6'x8' to 8'x16' in size. These units can treat water quality design flows up to 1.2 cfs. The system is installed online and includes an internal offline overflow bypass around the filtration chamber. The internal bypass capability is based on depth of the structure. The standard bypass capacity is 15 cfs but is larger for deeper units. A traffic-bearing lid is placed underneath the median or sidewalk adjacent to the roadway.

Basic Operation

The Curb Inlet StormFilter is composed of three bays: the inlet bay, the filtration bay, and the outlet bay. Stormwater enters the inlet bay through the curb inlet opening. The design flow is directed through a transfer opening to the filtration bay for full treatment.

Once in the filtration bay, the stormwater percolates horizontally through the media in the filter cartridges to the center tube. Treated water in the cartridge center tube is directed into the outlet bay by an under-drain manifold and discharged through the outlet pipe. Outlet pipes can be placed parallel, perpendicular, or up to 45° to the roadway. Overflow is directed over a weir wall between the inlet bay and the outlet bay, bypassing the filtration bay leaving accumulated pollutants undisturbed.

Curb Inlet Openings

Every Curb Inlet StormFilter is designed to meet local regulations governing the geometry of the curb inlet. This can be accomplished in two ways. One way is with an integrated face plate – the vault lid includes the face plate which is tied into the curb. Another way is with a cast-in-place face plate – the entire face plate is constructed by the contractor pouring the curb. Curb inlet openings can be 4', 7', or 10' in length.

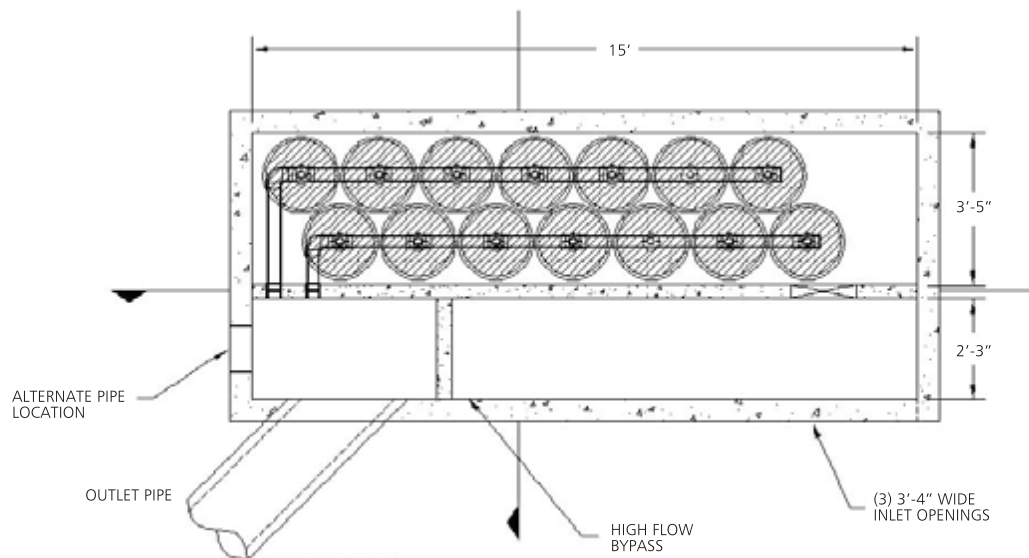

Curb Inlet StormFilter

Linear Grate StormFilter

The Linear Grate StormFilter is a precast vault that acts as the primary receiver of runoff, similar to a standard grated catch basin. The unit has H-20 rated traffic bearing lids that allow the filter to be installed under parking lots. The system consists of an inlet bay, filtration bay, and an outlet bay. Providing treatment as it enters the conveyance system reduces the overall head loss because the vertical drop from the finished grade into the conveyance system is also used to provide hydraulic pressure on the filter cartridges.

Basic Operation

Runoff enters the inlet bay by sheet flow from a paved surface or from an inlet pipe discharging directly to the unit. The inlet bay's internal baffle traps debris and floating oil and denser pollutants are directed into the filtration bay. Once in the cartridge chamber, polluted water ponds and percolates through a radial media filter cartridge. Treated water collects in the cartridge's center tube where it is directed by an underdrain manifold to the outlet pipe on the downstream side of the overflow weir. When flow rates exceed the water quality design value, excess water spills across the overflow weir, bypassing the cartridge bay and proceed directly to the outlet pipe. The integrated offline bypass ensures pollutants captured in the filtration bay are not washed downstream during peak flow events.

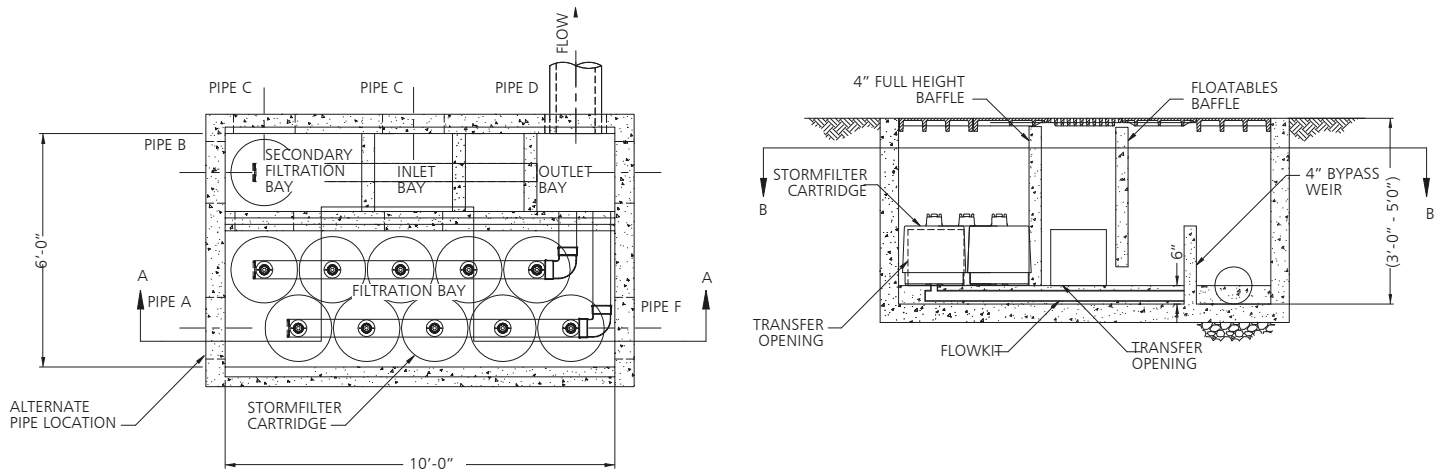

Linear Grate StormFilter

Grated Inlet Openings

The number of inlet grates and the size of the inlet bay are designed to capture the peak flow rates from the drainage area. The remaining area is devoted to the filtration bay and the outlet bay which are covered with removable plates for access during maintenance. The entire inlet bay, filtration bay, and outlet bay can be opened at one time allowing full access. In many cases, due to the shallow nature of the design, confined space entry is not required for maintenance.

Linear StormFilter

The Linear StormFilter consists of one or two precast concrete channels that are 10' or 20' in length and 2' 9" in width.

The Linear StormFilter is installed flush with the finished grade, functioning similar to a catch basin or trench drain. The top of the unit has either covers or doors for easy access. The Linear StormFilter is typically installed online like the precast StormFilter.

The Linear StormFilter unit treats water quality design flows up to 0.27 cfs.

Basic Operation

The Linear StormFilter can be installed either as the primary receiver of runoff, similar to a grated catch basin, or with an inlet stub and doors to receive runoff collected upstream.

The system is equipped with an internal overflow weir to ensure that there is no local flooding for storm events in excess of the design treatment flow. Maintenance costs for the unit are typically less because there are no confined space entry requirements, and access is quick and easy.

The Linear StormFilter is particularly useful where small flows are being treated or where the site is very flat and there is little available hydraulic head to spare.

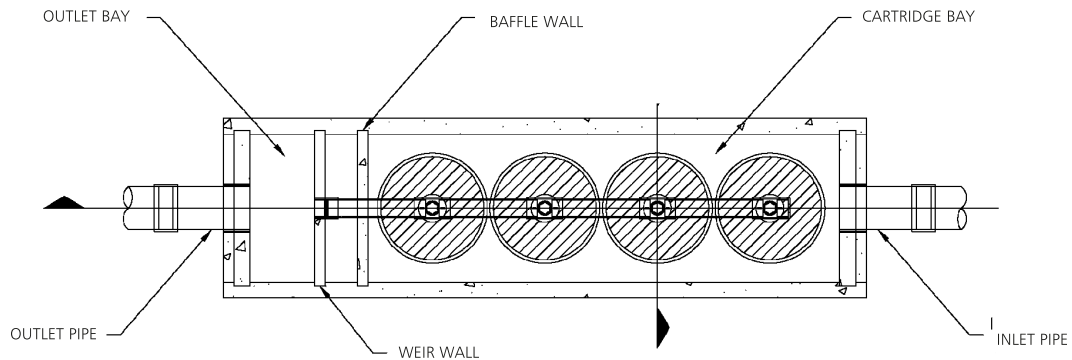

Linear StormFilter

Infiltration Configuration

Dry Well StormFilter

The Dry Well StormFilter provides treatment, infiltration and groundwater protection in a single structure. The system is designed to treat conveyed flow or sheet flow from small drainages. Multiple units can be installed to treat any size site. Because it provides treatment and infiltration in a single unit, the total number of structures and the amount of pipe required for the stormwater system are reduced.

The Dry Well StormFilter system is available in 48", 60" and 72-" pre-cast manhole top sections that are designed to be stacked on top of dry well infiltration risers. The StormFilter portion of the unit arrives fully assembled and ready to install, including an integrated concrete deck for the StormFilter cartridges. The system can also be retrofitted into existing 48" manhole dry wells.

Basic Operation

Stormwater enters the dry well unit through one or more entry pipes or channels at its top. It then percolates through the media in the StormFilter cartridge to the center tube. Treated water in the cartridge center tube is discharged to the infiltration section below, and then infiltrates into the surrounding soils through a number of small exit openings at the sides and bottom.

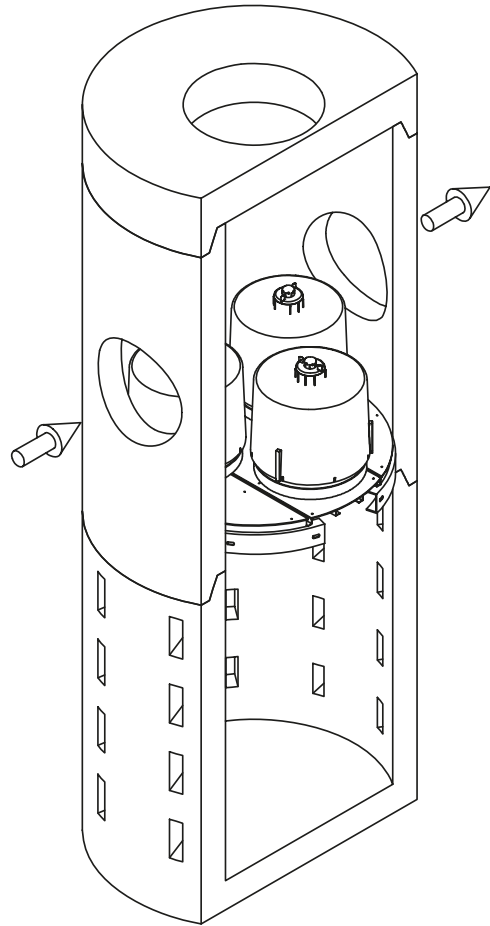

DryWell StormFilter

Roof Runoff Treatment Configuration

Downspout StormFilter

The Downspout StormFilter is an aboveground configuration that can be easily integrated into existing gutter systems to eliminate pollution from rooftop runoff. It typically occupies 2.5' x 5' footprint, and can fit most downspout configurations and sizes. Each unit holds two StormFilter cartridges, and single- and dual-stage options are available. It treats up to 14,000 square feet of rooftop area per dual-cartridge system.

StormFilter Cartridges

There are three cartridge heights available for StormFilter systems: 27", 18", and Low Drop. The most economical is the 27" tall cartridge. It can treat the highest flow rate per cartridge, which creates the smallest system with the lowest installed cost. The 27" cartridge requires 3.05' of driving head to operate. For sites with less driving head available, the 18" cartridge is the next best option. Lower flow rates per cartridge increase the footprint of the overall system but only 2.3' of driving head is required. For sites with very limited drop, the Low Drop cartridge only requires 1.8' of driving head.

Cartridge Flow Rates

Cartridge Type	Hydraulic Drop	Treatment Capacity (gpm)	
		1 gpm/ft ²	2 gpm/ft ²
StormFilter 27"	3.05'	11.25	22.5
StormFilter 18"	2.30'	7.5	15
StormFilter Low Drop	1.80'	5	10

StormFilter Media

The removal of site-specific pollutants can be maximized with the variety of filtration media available. In many cases, different media types can be combined so as to target a wide spectrum of pollutants. This ability to combine and use various media types allows the system to be easily adjusted to meet ever-changing site conditions and increasingly stringent regulatory requirements.

PhosphoSorb®

PhosphoSorb, a lightweight media comprised of Perlite (a heat-expanded volcanic rock) and activated alumina, removes total phosphorus (TP) by absorbing dissolved-P and filtering particulate-P simultaneously. The Perlite provides the capability to remove suspended solids while the activated alumina absorbs soluble phosphorus absorption.

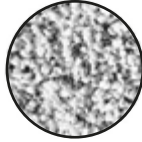

PhosphoSorb is composed of a slightly finer gradation than the field proven ZPG™ (Zeolite, Perlite, Granular Activated Carbon) media and will provide equivalent - or even better - removal of suspended solids. Initial field tests have indicated an increase in the TSS removal efficiency up to 10% over the field-proven ZPG media. The StormFilter with ZPG media has already received a General Use Level Designation for basic treatment in the State of Washington.

Perlite

Perlite is a natural, volcanic ash, similar in composition to glass and similar in appearance to pumice. To use perlite as a filter medium, it must first go through a heating process to yield a lightweight, multicellular, expanded form. This expanded form has a coarse texture, very low-density, high surface area, and stable, inert chemistry, all of which make perlite an excellent physical filtration medium.

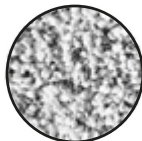

Perlite has proven to be our media of choice for sediment and oil removal. The multicellular nature of expanded perlite is the key to its excellent ability to trap sediments and adsorb oil. The coarse texture of the expanded perlite creates a bed of material with a very high porosity, which allows perlite to have the highest sediment and oil storage capacity of all of the available media options.

Zeolite

The term zeolite defines a family of both natural and synthetic, hydrous aluminosilicate materials with a highly porous mineral matrix that holds light, alkali metal cations (ideally sodium ions).



Zeolite has the ability to use a cation exchange reaction that removes other cations such as zinc, copper, lead, and ammonia from water. In the cation exchange reaction, the light metal cations in the zeolite matrix are displaced by the heavier metal cations, such as copper, in the water.

The zeolite used in our system is clinoptilolite, which has a cation exchange capacity (CEC) of approximately 100 to 220 meq/100 g. Clinoptilolite has inert characteristics that make it an excellent metals removal media option when CSF media cannot be used. It can be combined with other media such as GAC and perlite when metals are not of exclusive concern.

CSF® Leaf Media

CSF Leaf Media is a patented filtration media composed of composted deciduous leaves originating from the City of Portland, Oregon. Contech Engineered Solutions purchases the mature, stable, deciduous leaf compost and then processes it into an odorless, pelletized compost product with physical and chemical characteristics desirable for stormwater filtration.

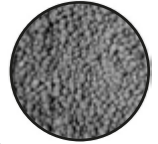

The patented compost process creates a material with excellent flow-through characteristics and stability in water. Not only do CSF Leaf Media consist of 100% recycled, all natural materials, but it also provides good removal of sediments and excellent removal of a wide range of toxic contaminants.

CSF Leaf Media provides the multitude of beneficial water treatment properties typical of soil in a form that is compatible with the compact, modular, media-based design of the StormFilter system. In addition to the physical filtration provided by the granular nature of the CSF Leaf Media, the complex chemistry of the compost also provides chemical filtration as well.

Sediment and total nutrients are removed through physical filtration. Oil, complexed metals, and anthropogenic organic contaminants such as herbicides and pesticides are removed through adsorption, the physical partitioning of organic compounds, such as pesticides, to carbon-rich materials, such as the compost.

Soluble metals are removed by cation exchange, as well as by complexation of metal ions to the organic chelating agents present in compost. CSF Leaf Media is an excellent, cost-effective, all-purpose media that epitomizes the potential value of recycled materials.

GAC

GAC (Granular Activated Carbon) is a widely accepted water filtration media used for the removal of organic compounds. It consists of pure carbon (originating from coal or charcoal) whose micro-porous structure has been enhanced through steam or acid "activation."

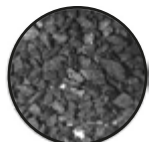

The high carbon content and porous nature of GAC accounts for its excellent ability to remove organic compounds through adsorption. Since adsorption is the physical partitioning of organic compounds to high carbon surfaces, the "activation" of the carbon (which creates GAC) endows it with an enormous surface area upon which adsorption can take place.

In situations where anthropogenic organic contaminants are of exclusive concern, GAC media provide the highest level of stormwater treatment compared to other available media options. However, because it is not very often the case that anthropogenic organic contaminants are of exclusive concern, GAC is usually combined with another media such as perlite or zeolite for the treatment of additional contaminants.

Combination of GAC with perlite constitutes the most cost-effective configuration, as the effectiveness of GAC is drastically reduced if it is coated with high concentrations of heavy oil or sediment, which can restrict access via surface pores to the interior of the GAC granules.

ZPG™ (Zeolite, Perlite, GAC blend)

This proprietary blend of zeolite, perlite, and granular activated carbon media is used to provide an alternative for CSF media for installations where leaf media cannot be used.

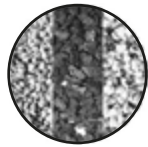

Laboratory and Field Testing

The StormFilter system is designed to meet the most stringent regulatory requirements. The field-proven performance of the StormFilter has led to hundreds of regulatory agency approvals nationwide as a standalone BMP.

The Stormwater Management StormFilter® is the first manufactured BMP to receive stand-alone approval through field testing and satisfying the total suspended solids treatment requirements in Washington and New Jersey.

Log on to www.conteches.com/stormfilter to view the following reports in full.

Field Monitoring Reports

Field Proven Performance of the StormFilter using the Technology Assessment Protocol - Ecology (TAPE) and Technology Acceptance Reciprocity Partnership (TARP) Tier II Protocol

1. Washington
 - a. Washington State Department of Ecology General Use Level Designation for Basic Treatment
 - b. Technical Evaluator Engineering Report (TEER). Gary Minton, Ph.D., P.E.
2. New Jersey
 - a. New Jersey State Department of Environmental Protection Final Certification
 - b. New Jersey Corporation for Advanced Technology (NJCAT) Field Verification Report

Laboratory Reports

Total Suspended Solids (TSS) Removal Using Different Particle Size Distributions with the Stormwater Management StormFilter.

Influences on TSS removal efficiency

Influence of analytical method, data summarization method, and particle size on total suspended solids (TSS) removal efficiency of the StormFilter

StormFilter removal efficiency with coarse/fine perlite media

Evaluation of the removal of silt loam TSS using coarse/fine perlite at 28 L/min (7.5 gpm).

StormFilter removal efficiency with ZPG media

Evaluation of the removal of SIL-CO-SIL 106 using ZPG media at 28 L/min (7.5 gpm)

StormFilter removal efficiency with coarse perlite

Evaluation of the removal of sandy loam TSS using coarse perlite at 57 L/min (15 gpm)

Support

- Drawings and specifications are available at contechstormwater.com.
- Site-specific design support is available from Contech Stormwater Design Engineers.

©2015 Contech Engineered Solutions LLC

Contech Engineered Solutions LLC provides site solutions for the civil engineering industry. Contech's portfolio includes bridges, drainage, sanitary sewer, stormwater and earth stabilization products. For information on other Contech division offerings, visit contech-cpi.com or call 800.338.1122

NOTHING IN THIS CATALOG SHOULD BE CONSTRUED AS AN EXPRESSED WARRANTY OR AN IMPLIED WARRANTY OF MERCHANTABILITY OR FITNESS FOR ANY PARTICULAR PURPOSE. SEE THE CONTECH STANDARD CONDITIONS OF SALE (VIEWABLE AT WWW.CONTECHES.COM/COS) FOR MORE INFORMATION.

The product(s) described may be protected by one or more of the following US patents: 5,322,629; 5,624,576; 5,707,527; 5,759,415; 5,788,848; 5,985,157; 6,027,639; 6,350,374; 6,406,218; 6,641,720; 6,511,595; 6,649,048; 6,991,114; 6,998,038; 7,186,058; 7,296,692; 7,297,266; related foreign patents or other patents pending.



CNTECH[®]
ENGINEERED SOLUTIONS

Jellyfish[®] Filter

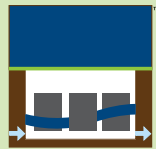

**Solutions
Guide**



Stormwater Solutions from Contech



Selecting the Right Stormwater Solution Just Got Easier...

It's simple to choose the right stormwater solution to achieve your goals with the Contech Stormwater Solutions Staircase. First, select the runoff reduction practices that are most appropriate for your site, paying particular attention to pretreatment needs. If the entire design storm cannot be retained, select a treatment best management practice (BMP) for the balance. Finally, select a detention system to address any outstanding downstream erosion.

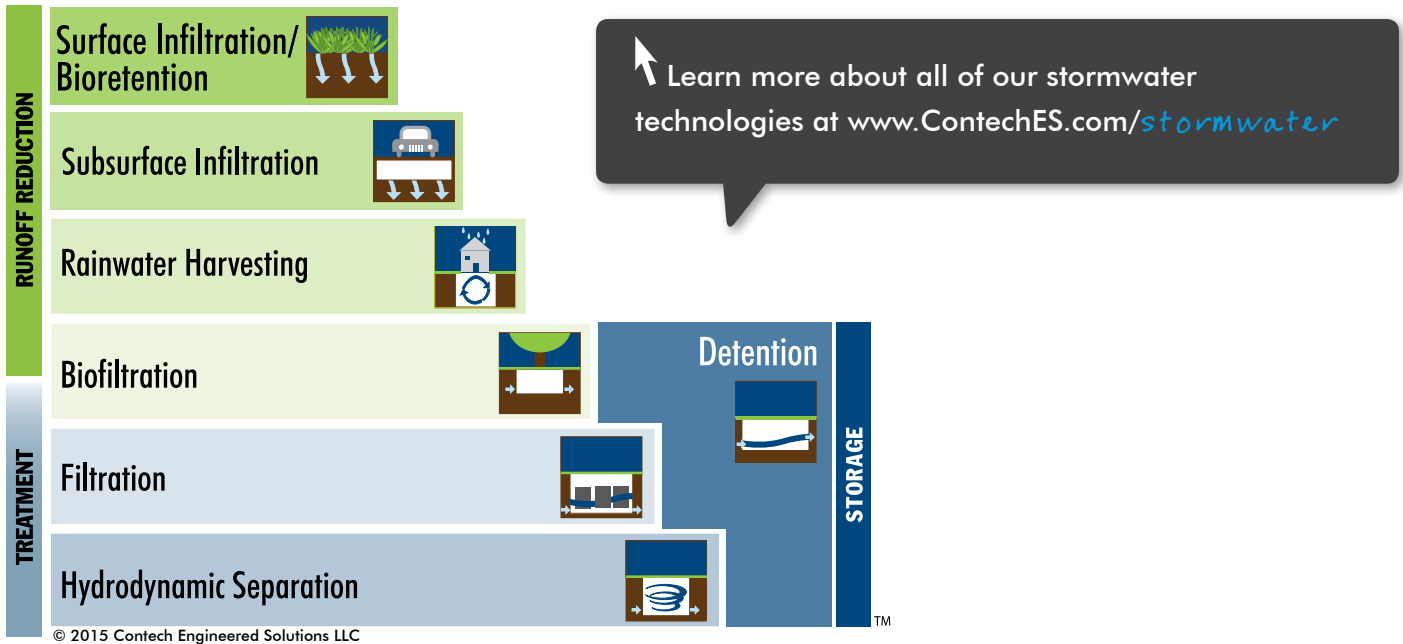

Learn About the Jellyfish[®] Filter

Go online and watch our animation to learn how the Jellyfish Filter works. The animation also highlights important features of the Jellyfish Filter including...

- Applications
- Performance test results
- Inspection and maintenance
- Regulatory approvals

To view the Jellyfish Filter animation, visit:
www.conteches.com/jellyfish



Jellyfish[®] Filter

Filtration as a Stormwater Management Strategy

Stormwater regulations are increasingly calling for more robust treatment levels. In addition to the removal of suspended solids, many regulations now require best management practices to remove significant amounts of nutrients, metals, and other common pollutants found in stormwater runoff. Meeting these regulations often requires the use of a filtration solution.

Low Impact Development (LID) and Green Infrastructure (GI) are complimented by filtration solutions. Benefits of LID and GI systems include retaining runoff and aesthetic appeal. Keeping LID and GI sites free from fine sediments, oils, trash, and debris while functioning as designed can be time consuming and costly.

As a result, the practice of combining LID and GI with filtration is becoming more common. Providing a single point of maintenance promotes proper system functionality and increases the aesthetic appeal by removing unsightly trash and debris.



A Jellyfish Filter Curb Inlet pretreats runoff entering a bioretention system

The Jellyfish[®] Filter - Setting New Standards in Stormwater Treatment

The Jellyfish Filter is a stormwater quality treatment technology featuring high surface area and high flow rate membrane filtration at low driving head. By incorporating pretreatment with light-weight membrane filtration, the Jellyfish Filter removes floatables, trash, oil, debris, TSS, fine silt-sized particles, and a high percentage of particulate-bound pollutants; including phosphorus and nitrogen, metals and hydrocarbons.

The high surface area membrane cartridges, combined with up flow hydraulics, frequent backwashing, and rinsable/reusable cartridges ensures long-lasting performance.

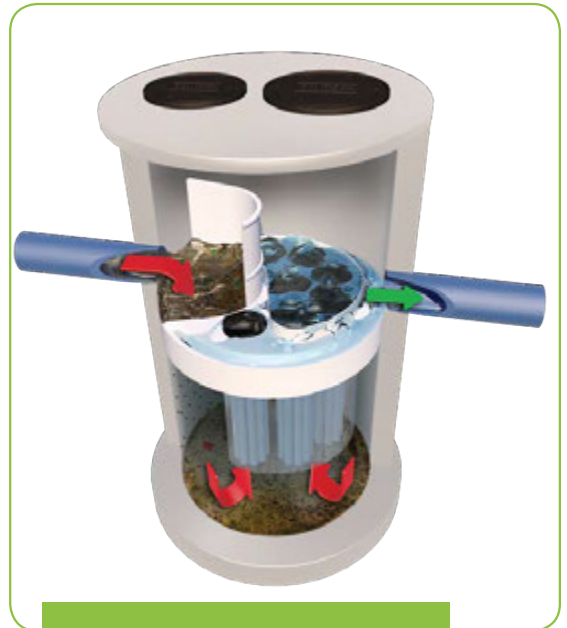

The Jellyfish Filter.



Jellyfish® Filter Features and Benefits

FEATURES	BENEFITS
1. High surface area, high flow rate membrane filtration	1. Long-lasting and effective stormwater treatment
2. Highest design treatment flow rate per cartridge (up to 80 gpm (5 L/S))	2. Compact system with a small footprint, lower construction cost
3. Low driving head (typically 18 inches (457 mm) or less)	3. Design Flexibility, lower construction cost
4. Lightweight cartridges with passive backwash	4. Easy maintenance and low life-cycle cost
5. 3 rd party verified field performance per TARP Tier II protocol	5. Superior pollutant capture with confidence

Jellyfish® Filter Applications

- Urban development
- Highways, airports, seaports, and military installations
- Commercial and residential development, infill and redevelopment, and stormwater quality retrofit applications
- Pretreatment for Low Impact Development (LID), Green Infrastructure (GI), infiltration, and rainwater harvesting and reuse systems
- Industrial sites



A Jellyfish Filter pretreats a bioretention/ bioswale system at a commercial site in Ontario, Canada.



A catch basin Jellyfish Filter is installed in a commercial development in Virginia.



A Jellyfish Filter provides treatment at an Industrial Park in Lake Tahoe, Nevada.

Jellyfish® Filter Field Performance Test Results

POLLUTANT OF CONCERN	% REMOVAL
Total Trash	99%
Total Suspended Solids (TSS)	89%
Total Phosphorus (TP)	59%
Total Nitrogen (TN)	51%
Total Copper (TCu)	>80%
Total Zinc (TZn)	>50%
Turbidity (NTU)	<15%

Sources:

TARP II Field Study – 2012 JF 4-2-1 Configuration

MRDC Floatables Testing – 2008 JF6-6-1 Configuration



Jellyfish® Filter Approvals

The Jellyfish Filter is approved through numerous state and federal verification programs, including:

- New Jersey Corporation for Advanced Technology (NJCAT) – Field Performance Verification per TARP Tier II Protocol
- Washington State Department of Ecology (TAPE –CULD)
- Maryland Department of the Environment (MD DOE)
- Texas Commission on Environmental Quality (TCEQ)
- Virginia Department of Environmental Quality (VA DEQ)
- New York Department of Environmental Conservation (DEC)
- City of Denver
- Los Angeles County
- Canada ISO 14034 Environmental Management – Environmental Technology Verification (ETV)
- Ontario Ministry of the Environment – New Environmental Technology Evaluation (NETE) – Certification



Learn more at www.ContechES.com/jellyfish



Jellyfish® Filter Configurations

The Jellyfish Filter is available in a variety of configurations. Typically, 18 inches (457 mm) of driving head is designed into the system. For low drop sites, the designed driving head can be less.

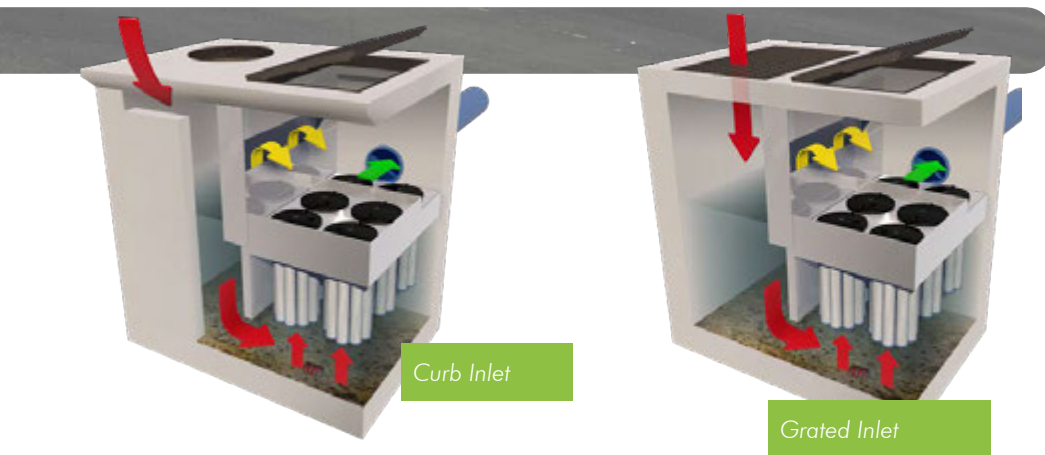
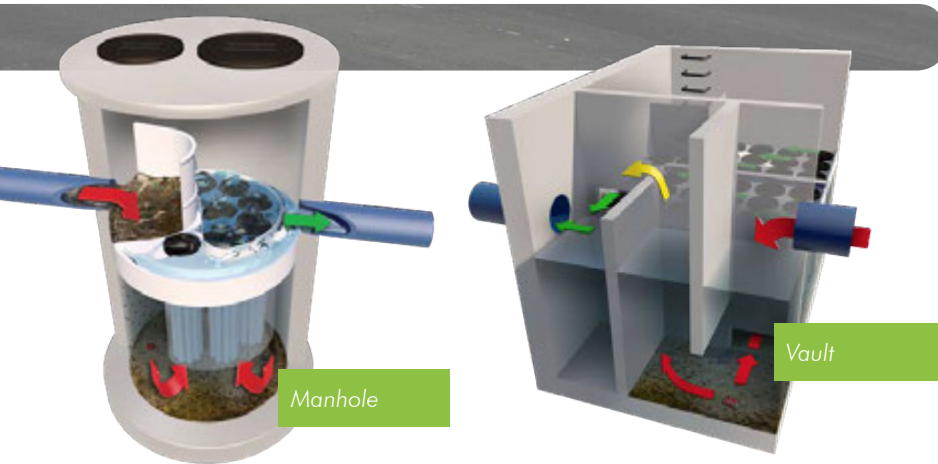

Lightweight Jellyfish Filter Configurations

Custom configurations include Jellyfish Filter tanks made from fiberglass for site specific applications.



A Jellyfish Filter was constructed from fiberglass to reduce the weight of the system, allowing for a suspended installation above an underground parking structure. The reduced weight eliminated the need for structural changes, and suspending the Jellyfish resulted in no loss of parking space, maximizing real-estate value.

Jellyfish[®] Filter Maintenance

Inspection and maintenance activities for the Jellyfish Filter typically include:

- Visual inspection of deck, cartridge lids, and maintenance access wall.
- Vacuum extraction of oil, floatable trash/debris, and sediment from manhole sump.
- External rinsing and re-installing of filter cartridges.
- Replacement of filter cartridge tentacles as needed. Cartridge replacement intervals vary by site; replacement is anticipated every 2-5 years.



The Jellyfish Filter tentacle is light and easy to clean.

Jellyfish[®] Filter Inspection and Maintenance Video

Inspecting and maintaining the Jellyfish Filter is easier than you may think. Watch the Jellyfish inspection and maintenance video at www.ContechES.com/jellyfish





LEARN MORE

- Access project profiles, photos, videos and more online at www.ContechES.com/jellyfish

CONNECT WITH US

- Call us at 800-338-1122
- Contact your local rep at www.ContechES.com/localresources

START A PROJECT

- Submit your system requirements on our product Design Worksheet www.ContechES.com/start-a-project

USE OUR ONLINE TOOLS

- Low Impact Development Site Planner www.ContechES.com/LIDsiteplanner



COMPLETE SITE SOLUTIONS

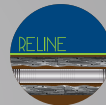
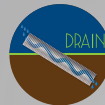

TREATMENT SOLUTIONS

Helping to satisfy stormwater management requirements on land development projects

- Biofiltration/Bioretention
- Stormwater Treatment
- Detention/Infiltration
- Rainwater Harvesting

PIPE SOLUTIONS

Meeting project needs for durability, hydraulics, corrosion resistance, and stiffness

- Corrugated Metal Pipe (CMP)
- Steel Reinforced Polyethylene (SRPE)
- High Density Polyethylene (HDPE)
- Polyvinyl Chloride (PVC)

STRUCTURES SOLUTIONS

Providing innovative options and support for crossings, culverts, and bridges

- Plate, Precast & Truss Bridges
- Hard Armor
- Retaining Walls
- Tunnel Liner Plate

NOTHING IN THIS CATALOG SHOULD BE CONSTRUED AS AN EXPRESSED WARRANTY OR AN IMPLIED WARRANTY OF MERCHANTABILITY OR FITNESS FOR ANY PARTICULAR PURPOSE. SEE THE CONTECH STANDARD CONDITION OF SALES (VIEWABLE AT WWW.CONTECHES.COM/COS) FOR MORE INFORMATION.



© 2018 Contech Engineered Solutions LLC, a QUIKRETE Company
800-338-1122 | www.ContechES.com
All Rights Reserved. Printed in the USA.

Get Social With Us!



Appendix H: Meeting Minutes

(THIS PAGE INTENTIONALLY LEFT BLANK)

acquisition of the properties along the south side of the street between Garey and Center Streets.

3. Work to be Completed as Part of Current Contract

HDR indicated that their current contract with Metro for the Link US project includes the following major project elements:

- Preparation of EIR/EIS for the proposed project
- Preparation of preliminary engineering/architectural plans and Design-Build procurement documents for the proposed project.

The Draft EIR/EIS is scheduled to be circulated in April of 2017, with certification of the environmental document planned for November of 2017. The preliminary design package is estimated to be complete by April of 2018, with work to be completed as part of the Design-Build contract to be initiated in early 2019.

4. Proposed Onsite Improvements at LAUS and Throat Area

HDR provided an overview of the analysis completed to determine the most appropriate approach for treating onsite stormwater runoff at the proposed station yard and throat area. HDR noted that the entire station yard and throat area was assumed to be impervious for the purpose of this analysis as the tracks in this area will either be supported on the concourse roof structure or on cellular concrete fill. The limits of the onsite area were assumed to extend from US-101 to the south to Vignes Street to the north. The following were key items related to this discussion:

- Passenger concourse and egress plaza
 - The existing ridge conditions within the existing Station Yard were used to divide the site into three on-site tributary areas. The total on-site disturbed on-site area is approximately 23 acres.
- Proposed LEED certification and applicability of City LID criteria
 - The stormwater system for Link US must conform to LEED Silver requirements. Further analysis is needed to determine if the City of Los Angeles LID requirements will also meet LEED credit requirements.
- Overall goals related to water quality and stormwater treatment
 - The BMP system will comply with the Municipal Storm Water Permit issued by the California Regional Water Quality Board. A pre-treatment system is proposed to remove pollutants before stormwater enters into a cistern system.
- Potential Tier 1 and Tier 2 BMP's considered
 - According the City of Los Angeles LID Manual, the following is the priority order for implementing BMPs:

- Tier 1: Infiltrate
 - Tier 2: Capture and Use
 - Tier 3: Biofiltration
 - Tier 1 is not feasible because infiltration cannot occur underneath railyard track or within 25 feet of structures. Also, based on preliminary geotechnical investigation, the water table, soil condition, and hazardous material are not favorable for infiltration.
 - Therefore, Tier 2 is proposed.
- Proposed cisterns and their location, size and function
 - Three cistern locations are proposed. One for each tributary area. Two of the cisterns are located west of the yard track (Cisterns #2 and #3), while the other is currently placed underneath the tracks (Cistern #1). Cistern #1 may be relocated to another location within the tributary area.
 - Cisterns will be sized at a minimum to meet LID requirements, 85th percentile storm (1.0 inch rain depth for project site).
 - Stormwater from the site will flow into a water quality unit for pre-treatment prior to discharging into the cistern for storage. A mechanical skid unit will manage the distribution of the captured stormwater for re-use; i.e. for irrigation. If non-potable uses are pursued, then a post treatment (filter and UV system) will be required as well as clearance from LA County Department of Public Health.
 - The water balance analysis is ongoing and will continue to be updated as the project progresses in its design. The current program is to collect stormwater and HVAC condensate to the cistern, and supply the landscape irrigation and toilet demands.
 - Based on this meeting, the City of Los Angeles (BOS) concurs with the concept of a cistern as an on-site BMP. There will be a follow-up meeting next week to discuss cistern and drainage in more detail.

5. Proposed Local Street Improvements

HDR and BOE discussed the applicability of the City's LID/green street requirements as they related to the offsite work south of LAUS within City of LA jurisdiction, which includes the new run-through track viaduct structure and the associated local street modifications. The following items of note were discussed as part of this agenda item:

- LABOE feels that based on current City policy, Metro would be treated as a developer with regard to the need to meet the City's LID guidelines for the local street reconstruction included as part of the Link US Project. Meeting the City's LID guidelines would involve the implementation and maintenance of City approved stormwater treatment BMP's as part of the street reconstruction. Metro disagreed with the City's position with regard to the maintenance and stated that they should not be responsible for the maintenance costs of the BMP's, which would be in perpetuity. Metro cited the agreement between the City of LA and Metro that was adopted as part of the Crenshaw LRT project for the construction and maintenance

of the stormwater treatment BMP's included as part of the Crenshaw Boulevard street reconstruction. This agreement stipulates that Metro will be responsible for the cost of the maintenance of the BMP's constructed as part of the project for a five year period, after which maintenance responsibilities will be relinquished to the City via a mutually agreed upon approach between Metro and the City.

- HDR noted that conventional BMP's involving infiltration such as curb cuts/planter boxes would not be applicable for use along the Commercial Street corridor due to the likelihood for soil contamination, existing soil impermeability, and high groundwater.
- Metro suggested considering an approach for treating project runoff that takes advantage one of the adjacent acquired parcels which could be converted into a pocket park or some other public space as part of the project. A stormwater treatment BMP could be incorporated into the design of a pocket park or other public space where stormwater is captured and reused to provide for landscaping irrigation. Another option would be to incorporate some sort of biofiltration BMP into the design of the park's landscaping elements. HDR agreed to explore this approach.

6. Next Steps

The group agreed to switch the day/time of the planned biweekly coordination meetings with BOE staff to alternate Wednesday afternoons so that Ammar can participate. The next meeting was scheduled for Wednesday September 28th.

Meeting Action Item Summary

No.	Action Item	Responsibility	Due Date
1	Metro and City of LA to continue discussions regarding maintenance cost responsibilities for any offsite stormwater BMP's included as part of Link US Project.	Metro/BOE	
2	HDR to consider potential BMP's for offsite stormwater treatment that could be integrated into potential pocket parks or other uses that could be considered for properties to be acquired along Commercial Street corridor?	HDR	