

Conceptual Design Report

LA RIVER PATH



September 2019



Metro[®]

CONTENTS

EX

EXECUTIVE SUMMARY	EX-1
<i>Project Overview</i>	EX-3
<i>Community Benefits</i>	EX-5
<i>Mission and Goals</i>	EX-7
<i>Existing Conditions</i>	EX-9
<i>Path Analytics</i>	EX-12
<i>Path Design</i>	EX-13
<i>Community Engagement</i>	EX-15
<i>Alternative Evaluation Process</i>	EX-18
<i>Path Alternatives</i>	EX-26
<i>Next Steps</i>	EX-33

01

PROJECT OVERVIEW	1
<i>Project Overview</i>	3
<i>Project Mission and Goals</i>	5
<i>Path Users and Benefits</i>	7

Community Feedback

Feedback from the community engagement process can be found throughout this report, particularly in the sections with the comment icon.

02

PROJECT CONTEXT	11
<i>The Los Angeles River Yesterday and Today</i>	13
<i>People Who Live Here</i>	19
<i>Project Stakeholders</i>	25
<i>Implementation</i>	27
<i>Operations and Maintenance Plan</i>	29

03

COMMUNITY OUTREACH	31
<i>Community Engagement Overview</i>	33
<i>Community Feedback on Path Mission and Goals</i> 	39

04

PATH ANALYTICS	45
<i>Analytics Introduction</i>	47
<i>Origin and Destination Analysis</i>	49
<i>Path Demand Analysis</i>	53
<i>Level of Service and Level of Comfort Analysis</i>	57

05

EXISTING CONDITIONS	67
<i>Mobility Connections</i>	69
<i>Corridor Conditions</i>	73
<i>Operations and Maintenance</i>	87

06

PATH DESIGN	91
<i>Guidance Resources</i>	93
<i>Path Users</i>	97
<i>Path Fundamentals</i>	101
<i>Path Setbacks</i>	111
<i>Path Crossings</i>	113
<i>Path Elements</i>	121
<i>Channel Operations</i>	125
<i>Elevators</i>	127
<i>Facility Typologies</i>	129
<i>Structures</i>	139
<i>Modular Design</i>	147

07

CHARACTER OF PLACE	151
<i>Design Vision</i>	153
<i>Art</i>	155
<i>Lighting</i>	157
<i>Wayfinding</i>	159
<i>Site Furnishings</i>	161
<i>Landscape</i>	163

08

GETTING TO THE PATH	165
<i>Access Opportunities</i>	167
<i>Community Connection Opportunities</i>	173

09

ALTERNATIVE EVALUATION PROCESS	179
<i>Alternative Evaluation Process</i>	181
<i>Feasible Alignment Options</i>	183
<i>Community Feedback on Path Types and Access Points</i> 	191
<i>Goal-Based Evaluation Criteria</i>	195

10

PATH ALTERNATIVES	221
<i>Path Alternatives</i>	223
<i>Community Feedback on Path Alternatives</i> 	233
<i>Next Steps</i>	235

PHOTO CREDITS	237
----------------------	------------

ACKNOWLEDGMENTS

LOS ANGELES COUNTY METROPOLITAN TRANSPORTATION AUTHORITY (METRO)

Mobility Corridors

Program Management

Art and Design

Environmental Compliance and Sustainability

CONSULTANTS

Project Management + Design

Jacobs Engineering

Alta Planning + Design

Technical Leads

IPV Delft

D'Leon Consulting Engineering

EcoKai Environmental, Inc.

Epic Land Solutions

FPL and Associates, Inc.

Historic Resources Group

Urban Strategies Group

VIRTEK Company

Wagner Engineering & Survey, Inc.

Wiltec

Outreach Leads

Katherine Padilla and Associates

Lee Andrews Group

The Robert Group

PROJECT STEERING COMMITTEE

Metro

City of Los Angeles

City of Vernon

County of Los Angeles

ACRONYMS

AASHTO American Association of State Highway and Transportation Officials

ADA Americans with Disabilities Act

ADAAG ADA Accessibility Guidelines

ATP Active Transportation Program

ATSP Active Transportation Strategic Plan

BNSF Burlington Northern and Santa Fe

BOE City of Los Angeles Bureau of Engineering

BRT Bus Rapid Transit

BSPM Bicycle Sketch Plan Model

BTDM Bicycle Travel Demand Model

Caltrans California Department of Transportation

CBM18 Corridors Based Model 18

CBO Community-Based Organization

CDC Centers for Disease Control and Prevention

CEQA California Environmental Quality Act

CHTS 2009 California Household Travel Survey

CPTED Crime Prevention Through Environmental Design

CPUC California Public Utilities Commission

DOJ United States Department of Justice

DOT United States Department of Transportation

FHWA Federal Highway Administration

GDBF Guide for the Development of Bicycle Facilities

GO General Order

HCM Highway Capacity Manual

HDM Highway Design Manual

HOPE Homeless Outreach Proactive Engagement

JPA Joint Powers Authority

LA-RIO River Improvement Overlay

LACDA Los Angeles County Drainage Area

LACDMH Los Angeles County Department of Mental Health

LACDPW Los Angeles County Department of Public Works

LACFCD Los Angeles County Flood Control District

LADOT City of Los Angeles Department of Transportation

LADWP Los Angeles Department of Water and Power

LARMP Los Angeles River Master Plan

LASD Los Angeles County Sheriff's Department

LOC Level of Comfort

LOS Level of Service

LPA Locally Preferred Alternative

LRFD Load and Resistance Factor Design

Metro Los Angeles County Metropolitan Transportation Authority (LACMTA)

MMD Micro-mobility devices

MRCA Mountains Recreation & Conservation Authority

MRDC Metro Rail Design Criteria

MUTCD Manual on Uniform Traffic Control Devices

NACTO National Association of City Transportation Officials

NBPD National Bicycle and Pedestrian Documentation Project

NEPA National Environmental Policy Act

NHTS National Household Travel Survey

OD Origin-Destination

O+M Operations and Maintenance

OMRRR Operation, Maintenance, Repair, Replacement, and Rehabilitation Manual

PDT Project Development Team

PHB or HAWK Pedestrian Hybrid Beacons

PROWAG Public Rights of Way Accessibility Guidelines

ROW Right of Way

RRFB Rectangular Rapid Flashing Beacons

SEGD Signage and Environmental Graphic Display

SCRRA Southern California Regional Rail Authority

SUPLOS Shared-Use Path Level of Service

TAZ Travel Analysis Zone

TDA₃ Transportation Development Act, Article 3

TOC Transit Oriented Community

UCLA University of California, Los Angeles

UPRR Union Pacific Railroad Company

USACE United States Army Corps of Engineers

WSE Water Surface Elevation



EX

EXECUTIVE SUMMARY



PROJECT OVERVIEW

Overview

The LA River Path project will design and construct an approximately 8-mile walking and bicycling path along the Los Angeles River between Elysian Valley and the City of Maywood through downtown Los Angeles (see Map 1). The project will close the longest remaining gap in the LA River Path to serve existing communities and meet future demand. When complete, this facility will provide a seamless 32-mile grade-separated regional corridor for walking, rolling, and bicycling from the San Fernando Valley to Long Beach along the Los Angeles River.

Metro, along with a number of local and regional organizations, has long identified closing the gap in the LA River Path between Elysian Valley and Maywood as a high-priority walking and bicycling infrastructure project, including the 2016 Metro Active Transportation Strategic Plan, the City of Los Angeles Mobility Plan 2035, City of Vernon Bicycle Master Plan, and the 2016 Metro LA River Bike Path Gap Closure Feasibility Study.

There are multiple project phases that will occur before the path can open in 2027. In Phase I (see Figure 1), the project team worked through conceptual design, which included technical studies to learn more about the corridor’s existing conditions, and outreach to understand the community’s needs and desires. As part of this process, path alternatives were developed that can overcome the physical and regulatory challenges identified throughout the corridor and best serve the community’s needs. These alternatives will be further studied during Phase II.

Phase II will begin in late 2019 and will take the project through the environmental clearance process and identify a locally preferred alternative (LPA). During Phase III, the project will progress through final design, permitting, and real estate. Construction is scheduled to begin during Phase IV, as early as 2023.

Figure 1. Project Timeline

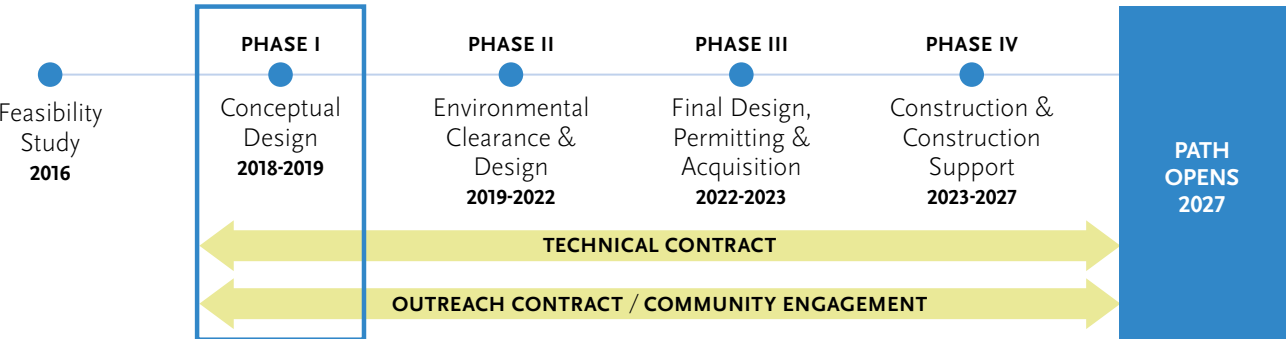

Map 1. LA River Path Project



Project Stakeholders

Agencies, stakeholders, and the community are integral to the planning and development process of the LA River Path project. A Steering Committee oversees the project and supports decision making, and a Project Development Team (PDT) provides interagency coordination, technical guidance, and problem solving. A community inclusive process brings together community members through stakeholder roundtables, community open houses, pop-up events, and surveys to discuss priorities and community needs.

Funding

The Los Angeles County Transportation Expenditure Plan for Measure M identified \$365 million (in 2015 dollars without escalation) for design and construction of the core path alignment.

What is This Report?

The Conceptual Design Report presents a vision for the future LA River Path that is efficient, sustainable, equitable, safe, and accessible to everyone. Driven by the project's mission and goals, the report aims to capture the project corridor, the community's needs, and recommend three path alternatives to be studied for environmental review. Included in this report are overviews of path analytics, existing conditions, path design concepts and guidelines, and the evaluation process used to identify path alternatives.

COMMUNITY BENEFITS

Populations Served

The LA River Path will serve the communities who live, work, and play near the corridor. Over one million people live within three miles, many of whom are not well served by infrastructure for walking and bicycling. Approximately 29% of the population in this area lives in poverty,¹ and more than 22% of the working-age population does not use automobiles as a primary mode of transportation. The largely industrial landscape holds tens of thousands of jobs, with more than 50,000 people employed in the City of Vernon alone.

The people who live within a half-mile and three miles of the river represent those who could walk and bicycle from home to the LA River Path. One-half mile is considered a comfortable walking distance, while three miles is considered a comfortable bicycle ride. A significant number of adults in the assessment area walk, bicycle, and take public transit as their primary mode of travel.

Within the LA River Path project corridor:²

85,000 

people live within walking distance of the Los Angeles River (1/2 mile)

OF THE **1** MILLION  people who live within biking distance of the Los Angeles River (3 miles)

22% of working-age people WALK, BIKE, or TAKE TRANSIT

Median household income is:

\$42,600

29% live in POVERTY

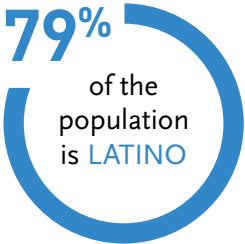

¹ The U.S. government defines the federal poverty level for a family of four as \$25,000 per year. The term “low-income individual” means an individual whose family’s taxable income for the preceding year did not exceed 150 percent of the poverty level amount, approximately \$37,500 for a family of four.

² ACS 5 year 2016

Map 2. Equity Focus Communities within 3 miles of LA River Path¹

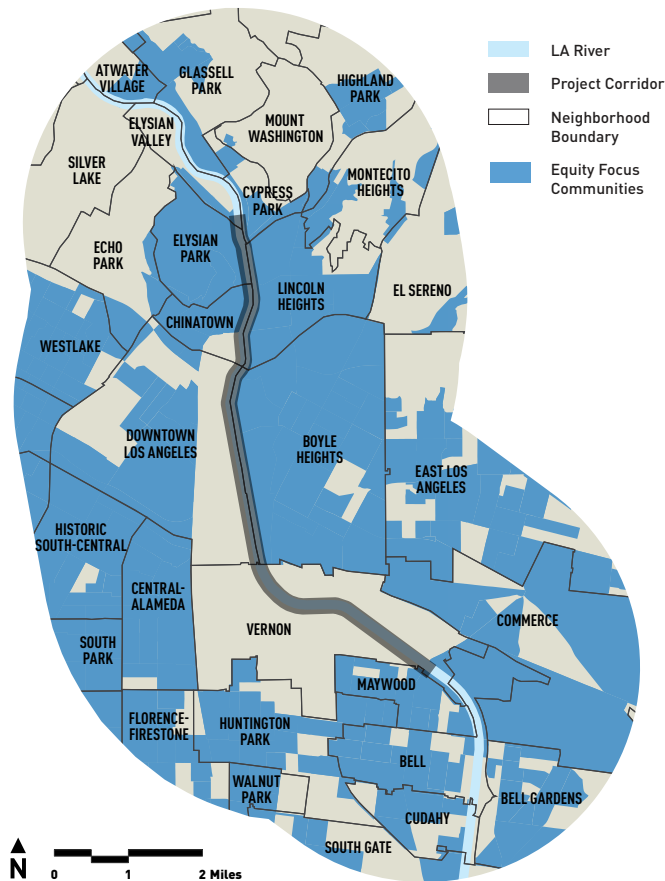

Equity

In February 2018, Metro adopted an Equity Platform Framework to acknowledge that access to opportunity should be a core objective of public decision making, public investment, and public service—and transportation is an essential lever to enabling that access. The equity platform provides a basis for Metro to actively lead and partner in addressing and overcoming those disparities.

In order to measure and track the future equity impacts of its transportation projects, Metro recently developed a framework to identify Equity Focus Communities (EFCs), or those communities that are most heavily impacted by gaps in equity in Los Angeles County.^{2,3}

The LA River Path project used this framework to identify the EFCs within three miles of the project corridor (Map 2). EFCs exist along both sides of the project corridor, and include the communities of Elysian Valley, Lincoln Heights, Boyle Heights, and the City of Maywood, among others. Approximately 72% of the estimated population of the census blocks within 1/2 mile of the project corridor live in an EFC.

The LA River Path will help promote access to opportunity in these EFCs by providing a safe, reliable, and low-cost active transportation corridor for the people that live there. The future path will connect these communities with transit, job centers, and other key destinations, increase active transportation mode share, and contribute to lower greenhouse gas emissions.

Equity considerations for the LA River Path will be addressed during design and planning, as well as throughout the community engagement process, to ensure the facility planning, design, and implementation addresses the concerns of the communities the path will be serving.

¹ ACS 2017, 5 year

² Metro Planning and Programming Committee, June 19, 2019, Long Range Transportation Plan Update

³ For the purposes of identifying EFCs, Metro is using the following thresholds:

- >40% Low Income
- >80% Non-white
- >10% Zero Car
- Meets low income and EITHER non-white OR zero car thresholds

MISSION AND GOALS

Overview

The project is driven by a mission statement and goals, which were shaped by the project stakeholders and the community through the public engagement process.

At the outset of the project, engagement activities were focused on familiarizing the community with the LA River Path project and gathering feedback to help develop the mission statement and goals. Community members were asked to comment on how they currently use the Los Angeles River, as well as their vision and goals for the future path.

Several consistent themes emerged during this process:

- Create a great user experience
- Make the path safe
- A desire to use the path for recreation/commuting
- Provide access to transit, jobs, and key destinations

This feedback was used to develop the project mission statement and goals outlined on the next page.

Figure 2. Community members' comments were categorized by the six project goals.

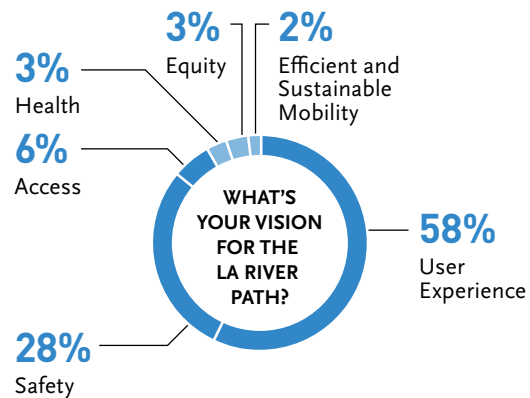







When asked to describe their vision for the path and prioritize the issues most important to them, community members overwhelmingly provided comments relating to two goals: User Experience (58%), e.g., landscaping, shade, and maintenance, and Safety (28%), e.g., lighting and separation of users. An overview of engagement activities can be found on page EX-15, and additional feedback on mission and goals can be found in Chapter 3.

Mission Statement

Create a safe and world-class active transportation corridor along the Los Angeles River between Elysian Valley and Maywood for people of all ages and abilities that enhances recreation, livability, regional connectivity and provides:

- *An outstanding user experience*
- *Access to opportunity*
- *Separation from vehicular traffic*

Goals

	Safety	Create a path that improves safety from existing conditions.
	Access	Create a path that increases access from local neighborhoods to employment centers, regional destinations, resources, and amenities, including healthcare services.
	Efficient and Sustainable Mobility	Create a path that reduces vehicle miles traveled by allowing people to walk and bicycle in a low-stress environment through and within Los Angeles County, reducing trip lengths, and expanding travel choices.
	Equity	Create a path that improves access to opportunity for historically under-invested communities, especially in low-income communities of color.
	User Experience	Create a path that feels safe, comfortable, and is activated by the people who are drawn to it, because it is a world-class transportation corridor.
	Health	Create a path that inspires physical activity and opportunities for healthy choices in everyday life.

EXISTING CONDITIONS

Existing Conditions

The eight-mile project corridor exists within a complex landscape; it follows the flow of the river and is surrounded by rail, roads, utilities, bridges, and pathways. Many of the neighborhoods adjacent to the project corridor are predominantly industrial, with high volumes of truck traffic, deteriorated roadways, a lack of sidewalks, and at-grade rail crossings. There are also high volumes of freight and passenger rail surrounding portions of the corridor, creating a barrier between the proposed path and on-street mobility connections to communities. More information on the project corridor's context and existing conditions can be found in Chapter 5.

EXISTING PATHS ALONG THE LOS ANGELES RIVER

There are 24 miles of existing path along the Los Angeles River: the Los Angeles River Greenway Trail to the north of the project corridor and the Los Angeles River Bicycle Path to the south. Once complete, the LA River Path project will connect the two existing paths to create 32 continuous miles of pathway along the Los Angeles River. Public feedback about the existing paths reflects a lack of connectivity, safety, and high-quality path design.

Three agencies conduct operations and maintenance (O+M) on the existing LA River Path: the City of Los Angeles, Los Angeles County, and the Mountains Recreation and Conservation Authority (MRCA). However,

several city departments contribute to overall O+M, leading to a complicated structure.

MOBILITY CONNECTIONS

The LA River Path will connect to on-street bicycle networks via access points. Potential access points were selected to connect to existing, funded, and planned walking and low stress bicycling infrastructure such as Class III neighborhood bicycle routes (i.e. shared-use, low volume, low-speed neighborhood streets), and Class IV protected bikeways. In addition to bicycle network connections, the LA River Path will also provide connections that serve people walking and taking transit including connections to Union Station, and Gold and Blue Line Stations.

THE RIVER CHANNEL

A driving consideration for the alignment of the LA River Path is the configuration of the Los Angeles River channel, which is broadly configured into two channel shapes, trapezoidal and rectangular, with a channel width ranging from approximately 200 to 500 feet. The trapezoidal channel is wider and features sloped walls, while the rectangular channel is more narrow with vertical walls.

HYDROLOGY

The primary function of the Los Angeles River is flood protection. It is important to maintain flood control for public safety, to protect the neighborhoods surrounding the Los Angeles River from flooding, and to protect the public from flood waters.

Figure 3. Hydrology

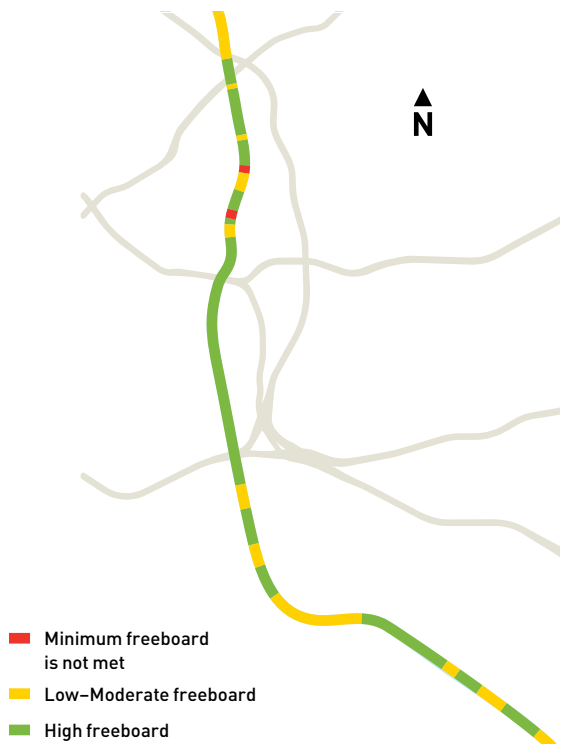

In order to analyze the feasibility of constructing a path within the Los Angeles River corridor, United States Army Corps of Engineers (USACE) HEC-RAS (5.0.7 version) hydraulic modeling software was used to evaluate the existing hydraulics of the Los Angeles River. The model results provided water surface elevations (WSE), minimum freeboard, channel velocity, and the Froude number along the channel profile (a value that describes open channel flow).

Freeboard is the space between the top-of-bank and the computed WSE. It can be used to identify areas along the channel where the river has relatively more or less hydraulic capacity, or where the channel may have more or less room for the path.

The project team considered hydrologically constrained areas when developing and evaluating the feasibility of path alignments.

RAIL AND UTILITY CORRIDORS

The Los Angeles River is an important corridor for both commuter and freight railways. They run along both the east and west banks as well as across the river on at-grade and elevated bridges. The LA River Path will need to be designed within the limitations of the existing rail ROW. Once opened, the path will not impact rail operations and will provide secure fencing and safety measures when it is near railways.

Utility corridors run along and across the Los Angeles River, providing power and services to many residential and industrial communities. The types of utilities in the area include electric, gas, telecommunications, cable, water, sewer and storm drain, and oil.

HAZARDOUS MATERIALS AND GEOTECH

Hazardous materials from current and historical land uses are present throughout the assessment area.

The presence of hazardous materials could impact the design and construction of the path. In addition, design features could be impacted by seismic shaking and its secondary effects. As the project moves forward, a comprehensive geologic and geotechnical investigation will be conducted to inform pathway design.

Photos, next page:

02. Bridges and rail lines along the LA River Path corridor
03. Utility towers along the LA River Path corridor
04. Trapezoid channel
05. Box Channel

Figure 4. Bridges and Historic Resources

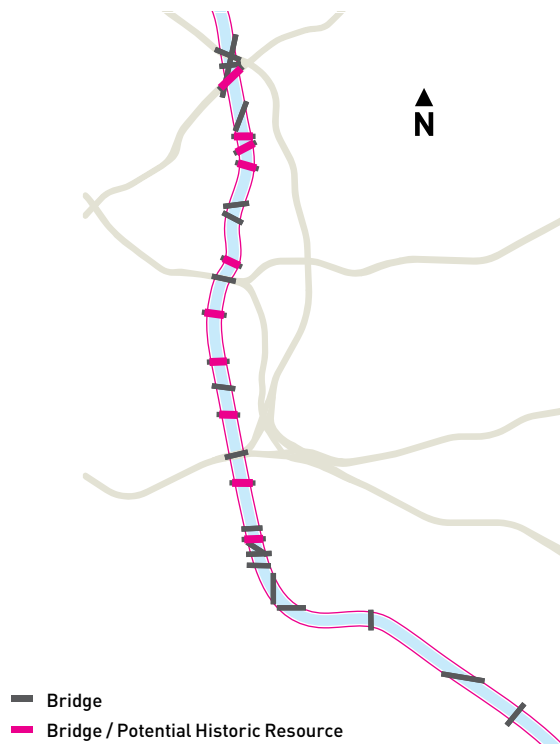

BRIDGES AND HISTORIC RESOURCES

There are thirty bridges that cross the Los Angeles River within the project corridor including many historic Beaux Arts style bridges built between the 1910s-1940s. Bridges pose challenges for the LA River Path design as the alignment will have to traverse over, under, or through the existing bridge structures.

PROPERTY OWNERSHIP

The land along the corridor includes publicly and privately held property, both within the river channel and along the top-of-bank. The channel itself is owned in large part by the City of Los Angeles north of Washington Boulevard and by the Los Angeles County Flood Control District (LACFCD) south of S. Downey Road.

The USACE and LACFCD hold flood control easements throughout the LA River Path project corridor. The easements extend beyond the channel along the top-of-bank.



PATH ANALYTICS

Overview

The design of the LA River Path will respond to the needs of people who will use the path. One of the comments consistently heard through the community engagement process was the existing paths along the Los Angeles River feel unsafe because they are too narrow for people walking and bicycling to share comfortably. The future path will be a world-class facility that provides a safe and comfortable user experience.

Demand

The project team conducted a demand analysis in order to understand how many people will use the LA River Path.

It is anticipated that in 2035 the LA River Path within the project corridor will serve up to 5,900 daily walking and bicycling trips. The busiest areas of the path are expected to be through the downtown Los Angeles corridor of Boyle Heights and the Arts District, followed by the northern section, near Chinatown and Lincoln Heights. Activity decreases as the path moves south through Vernon.

The projected demand of the LA River Path, as well as how people are using the path, will impact the user experience. To provide a high quality experience that is safe, efficient, and comfortable for future path users, the project

Figure 5. Demand Diagram

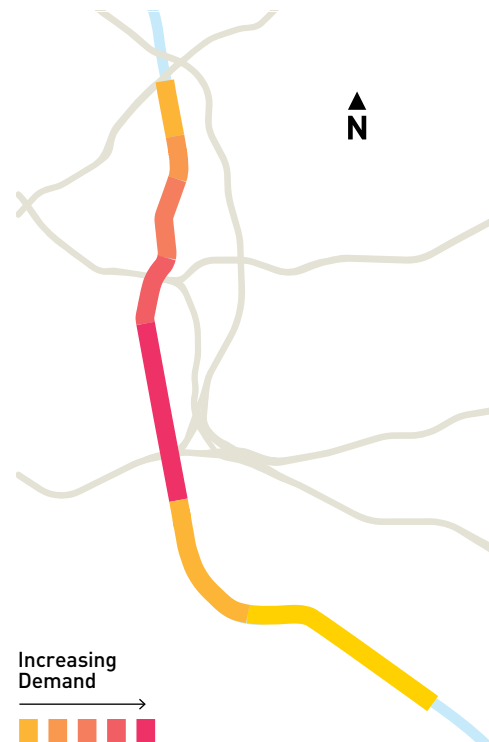

team performed a Level of Service (LOS) and a preliminary Level of Comfort (LOC) analysis. A final LOC analysis will be conducted during the environmental and clearance phase of the project. The LOS + LOC analyses can be used to help inform path width and configuration.

Based on results of the LOS analysis, preliminary considerations for path widths range from 14'-20' and may be shared or separated use along the corridor. Widths and facility configurations should respond to projected pathway demand. Additional information on path analytics can be found in Chapter 4.

PATH DESIGN

Design Guidelines, Path Types, and Structures

Throughout the corridor, the path design will change to respond to the constraints and needs of various locations. This project will draw on existing national, international, state, and local design guidance, standards, and best practices to create solutions for the complex environment of the Los Angeles River channel. Chapter 6 describes the design guidelines and structural options under consideration.

Character of Place

The path may include design elements that improve safety and security for path users, enhance the attractiveness, comfort, and enjoyment of the path as a transportation and recreational corridor, and contribute to the path as a destination in and of itself. Path elements are important along the path as well as at access points, and may include features such as public art, lighting, wayfinding, landscaping, and site furnishings, among others. Chapter 7 describes these elements in more detail.

Access and Community Connection Opportunities

Access points and connections to other transportation options, such as on-street bicycle and pedestrian facilities and public transit, will ensure the LA River Path is a functional and enjoyable part of the greater Los Angeles transportation network. While the size and features of access point areas may vary based on community needs, path user demand, available space, and the surrounding context, these spaces will allow for placemaking opportunities along the path. More information on access point opportunities and community connections can be found in Chapter 8.

Path Types

Due to the constrained nature of the corridor, there are limited places where the path can go. The project team considered four general categories of path types, with structural variations within each category. See Chapter 6 for additional detail on path types.

Figure 6. Elevated

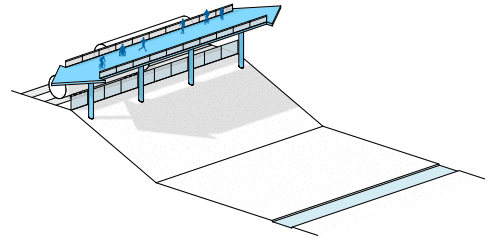
**ELEVATED**

An elevated path type has a path supported by piers and is valuable for ramping and crossing over roadways, rail, and other at-grade obstacles. The path type can be at the top-of-bank or in the channel.

Figure 7. Top-of-bank / Cantilevered

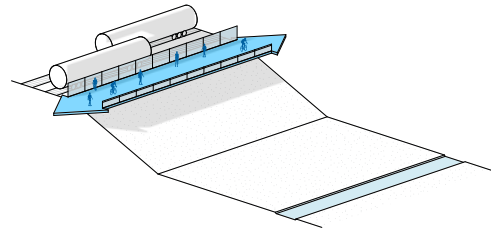
**TOP-OF-BANK / CANTILEVERED**

A top-of-bank path type is located at the top of the channel wall. Where enough space is available, it could take the form of an at-grade path. Where space is limited along the top-of-bank, a cantilevered path may be used. A cantilevered typology uses a structure that hangs over the top of the channel wall but is supported at the top-of-bank.

Figure 8. Incised

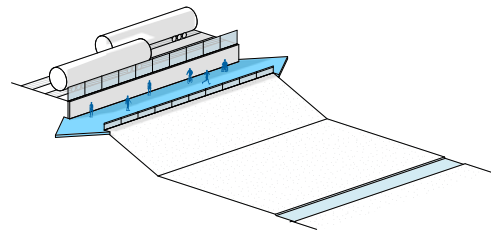
**INCISED**

An incised path type cuts the path into the channel embankment. This path type is feasible even where there is no space along the top-of-bank and for is applicable both trapezoidal and rectangular channel configurations.

BOTTOM-OF-CHANNEL

A bottom-of-channel path type locates the path on the flat bottom of the channel. It is not impacted by adjacent top-of-bank conditions. However, it is the typology most difficult to access and most at risk of seasonal flooding.

Figure 9. Bottom-of-Channel

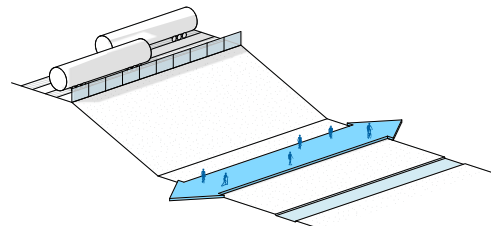

COMMUNITY ENGAGEMENT

Engagement Activities

Community input played an important role throughout the conceptual design phase of the LA River Path project, helping to inform the project mission statement, project goals, potential path types, access point opportunities, and path alignment analysis process. In an effort to better understand the communities that live in and near the assessment area, their priorities, and how the project could best meet their needs, the project team held a number of different outreach events and administered two online survey tools during the conceptual design phase.

Thirty-six public engagement events were held during this phase. Events included pop-up events, stakeholder roundtables, and community open house meetings. In addition, the project team held meetings

Outreach Activities Between August 2018 and July 2019:

- 9 Community Open Houses with **300+** Attendees
- 4 Stakeholder Round Tables
- 6 PDT Meetings
- 23 Pop-up Events

We collected **4,600+** In-person comments and **3,800+** Survey responses

Figure 10. Outreach Schedule by Topic

In-person engagement Online engagement Video

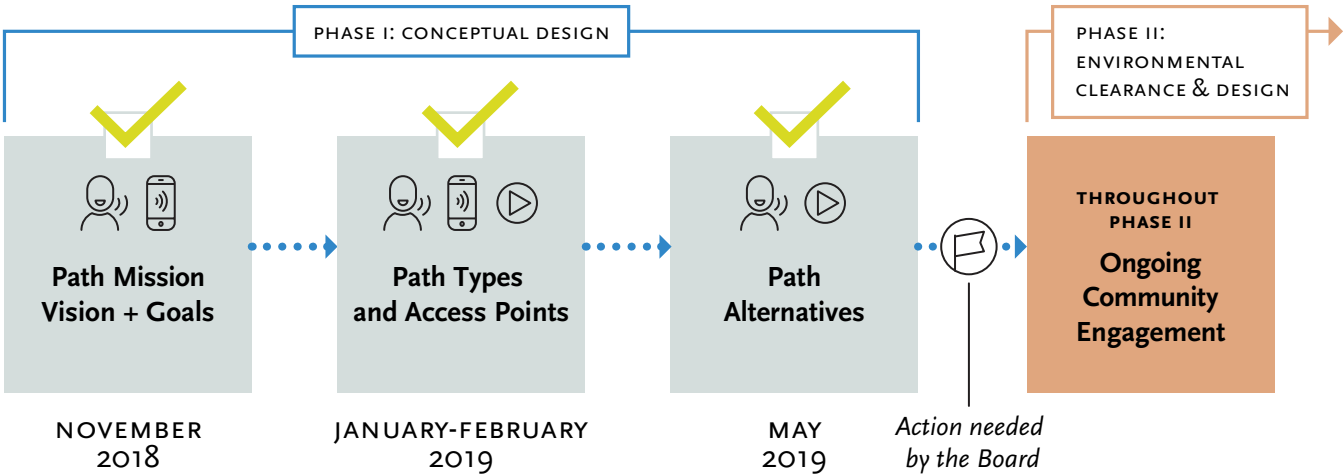

with neighborhood councils, residential block groups, community-based organizations, business owners, and other stakeholders. Additional innovative engagement tools included in-person and online surveys, online videos, and targeted youth outreach.

The project team sought to capture community feedback on topics such as project vision and goals, path types, and preferred access points to guide the evaluation of different path alignments, and ultimately identify three top-performing path alternatives. Overall, over 4,600 in-person comments and 3,800 survey responses were received during the conceptual design phase.

Innovative Engagement Strategies

WEBTOOLS

The LA River Path project team employed two webtools to offer community members an additional method with which to share their priorities and provide feedback. To better understand community members' demographics, current use of the existing paths north and south of the project corridor, and vision and goals for the future path, an online survey was run between September and November 2018. In-person surveys were also conducted at locations along the existing paths and at nearby Metro Gold Line stations. The project team recorded 1,915 responses during this period of outreach.

A second webtool focused on access points and path types ran from February to March

Photos, next page:

06. Still from Metro's LA River Path Project video, February 6, 2019
07. Youth outreach board
08. Still from Metro's LA River Path Project video, February 6, 2019
09. Still from Metro's LA River Path Project video, February 6, 2019
10. Screenshot of LA River Path survey homepage
11. Still from Metro's LA River Path Project video, February 6, 2019
12. Screenshot of LA River Path survey webtool

2019. This interactive survey tool captured community members' priorities for path types and access points, and allowed the project team to capture feedback from a wider audience. The LA River Path project received 1,912 responses through this online webtool.

YOUTH ENGAGEMENT

In an effort to reach the next generation of path users, the LA River Path project team participated in the Los Angeles River Youth Summit in November 2018. High school students from throughout the communities adjacent to the Los Angeles River participated in the summit and provided feedback on their goals and vision for the future path.

ONLINE VIDEOS

Metro produced two informational videos about the LA River Path project. The first video provided an overview of the project and showcased voices from community members who live in the study area.

The second video was produced for community members who were unable to attend the community meetings, allowing them to keep up to date on the project's goals, priorities, and recommended path alternatives.

The videos were promoted through Facebook and Metro's project website, as well as through email to those on Metro's project distribution list.

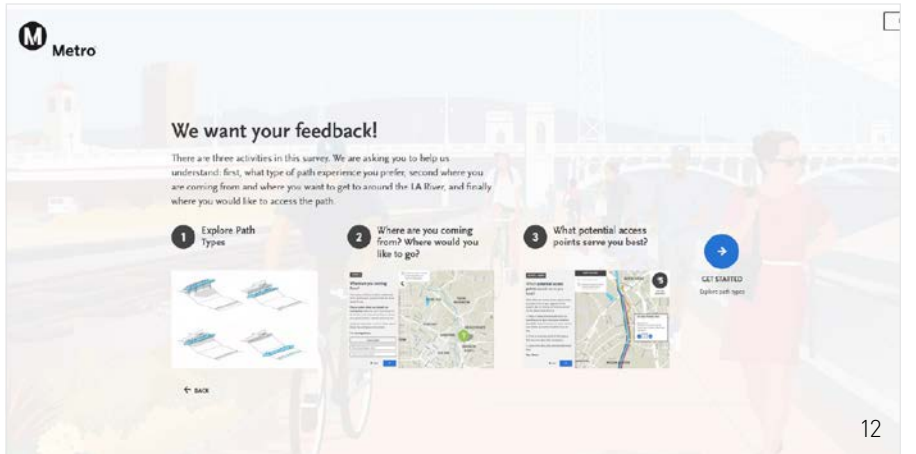
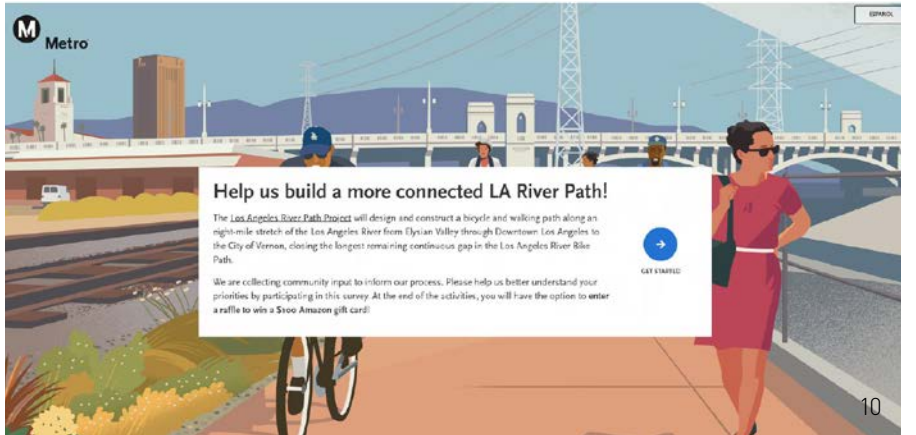

06

07

08

09

10

11

12

ALTERNATIVE EVALUATION PROCESS

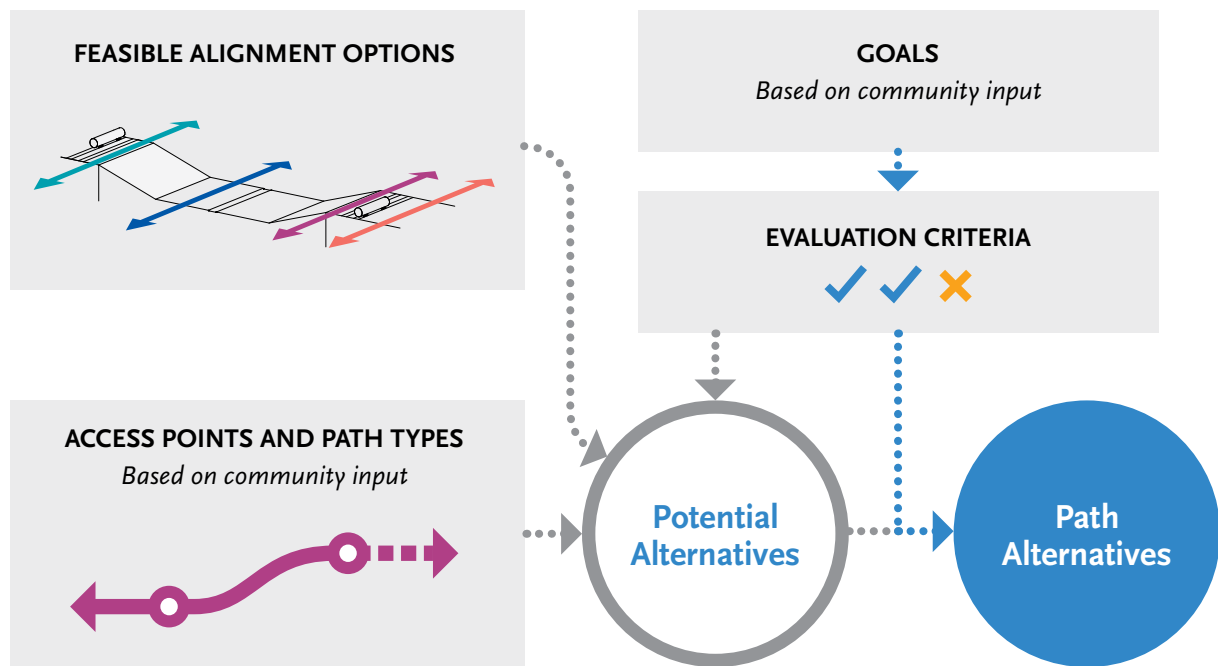

Approach

There are dozens of unique combinations of access points, river crossings, and path types that could be considered for the LA River Path.

An alignment evaluation process was used to create, filter, and revise alignment options and to inform the selection of three path alternatives to be studied during the environmental clearance and design phase of the project.

The project team used the information developed during the existing conditions assessments to determine a range of feasible alignment options, including potential path locations, path types, and access points.

To ensure the project would best address community needs and desires, the project team presented the feasible access points

and path types to the community in January and February 2019. The feedback received was used to analyze how well each option responded to community preferences.

The potential alternatives were also screened against evaluation criteria related to the six project goals. The three path alternatives that responded best to both community feedback on access points and path types and to evaluation criteria were ultimately presented to the community for their feedback in May 2019. Based on the positive response received, these three alternatives were selected to move forward to environmental review.

The alternative evaluation process is described in detail in Chapter 9.

Feasible Alignment Options

A series of steps was undertaken as part of the analysis process. The objective of the first step was to develop preliminary yet feasible alignment options. In subsequent steps, these feasible alignment options were refined and screened against the evaluation criteria to identify five potential alternatives and ultimately three path alternatives.

The project team began by studying the corridor and brainstorming a wide range of possible ways for the path to close the existing corridor gap. The team identified functional conceptual options for the horizontal configuration, path types, and access points for the project. The intent of this step was to thoroughly explore the many different ways a path could weave through the corridor.

All feasible alignment options were required to fulfill the project mission statement, as identified in Chapter 1. To ensure this, the project team screened the wide range of design variations against a set of fatal flaw criteria, baseline requirements without which the path cannot be successfully designed or constructed. The purpose of these criteria were to remove design options from consideration if it was apparent from a technical perspective that the options would not fulfill the mission statement of the project. There were five fatal flaw criteria used for the analysis:

ACCESSIBLE, CONSISTENT, AND SAFE:

The path is accessible, consistent, and safe for path users of all ages and abilities.

FLOOD PROTECTION:

The path must not impede the existing hydrological function of the Los Angeles River corridor.

HISTORIC RESOURCE IMPACTS:

The path avoids significant impacts to historic resources.

PERMITTING AND CONSTRUCTABILITY:

The path can be permitted and constructed without major delay or complexity.

COST:

The path can be constructed on budget based on preliminary cost estimate ranges.

ACCESS POINTS AND PATH TYPES

Based on Community Input

Community preferences on access points and path types also informed the development of the potential alternatives.

As part of the development of feasible alternative options, the project team determined a range of feasible access points and path types. These access points and path types were presented to the community through open house events, an online video, and an interactive online survey tool. The feedback received was later used to analyze how well each potential alternative responded to community preferences.

Community members preferred access points that provide maximum connectivity to job centers, parks, and transit. Top ranked access points included Los Angeles State Historic Park/Main Street (a connection to parks), and Union Station and Washington Boulevard (connections to transit and jobs), all of which are included in the three top-performing alternatives for the LA River Path. Community members also prioritized access points that connect neighborhoods to the east and west of the river, such as 1st Street and 7th Street.

Figure 11. Community members were asked to vote for their preferred path types.

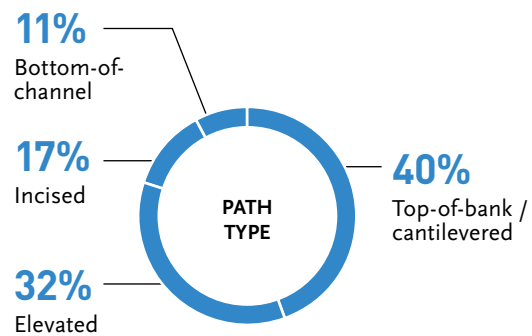

Because connecting neighborhoods was a priority for community members, all-west alignments and mostly-east alignments with minimal crossings were considered to be low performing characteristics.

When asked about path type preferences, community members overwhelmingly supported the top-of-bank/cantilevered (40%) and elevated (32%) path types because of their potential to stay open year round. Because the bottom-of-channel path type has a higher likelihood of closing due to flooding on the path, it was considered to be a low performing characteristic.

Additional feedback on path types and access points can be found in Chapter 9.



13

Which potential access points would serve you best?
 ¿Qué puntos de acceso potenciales le servirían mejor?

NORTH SEGMENT
SEGMENTO NORTE

- EAST SIDE** Possible path alignment and access locations based on existing conditions
- EAST BANK** Posibles alineaciones del camino y puntos de acceso basados en condiciones existentes
- WEST BANK**
- IN CHANNEL**



14

EX-21
 LA RIVER PATH · CONCEPTUAL DESIGN REPORT



15



16



17

GOALS

Based on Community Input

To understand the benefits, challenges, and relative strengths of the potential alternatives, the project team developed a process to measure each alternative against each of the six project goals: Safety, Access, Efficient and Sustainable Mobility, Equity, User Experience, and Health.

EVALUATION CRITERIA

Evaluation criteria were developed with input from the community and used to help assess how well the alternatives fulfill the project goals.

For each criterion, performance metrics specifically indicate how the evaluation was performed. Most of the performance metrics are quantitative, and were assessed using a data-driven approach. Some performance metrics are qualitative, assessed on the understanding of the site context and path design practices.







For example, the performance metric to measure the ‘access to points of interest’ criterion evaluated the alternatives’ access points’ proximity to regionally and locally significant destinations such as commercial areas, schools, and parks.

The project goals and evaluation criteria are summarized in Table 1.

Photos, opposite:

13. Community open house in Cypress Park.
14. Access point outreach board.
15. Community open house at Sci-Arc.
16. Community open house in Cypress Park.
17. Community open house at Sci-Arc.

Table 1. Summary Goals

GOAL	CRITERIA	RELATED TO ACCESS POINTS	RELATED TO LINEAR ALIGNMENT	QUANTITATIVE APPROACH
 Safety	Traffic Safety	●	●	●
	Recovery and Rescue	●		●
 Access	Access to Employment	●		●
	Access to Points of Interest	●		●
	Access to Services	●		●
	Aligns with Planned Projects	●	●	
 Efficient and Sustainable Mobility	Reliability		●	●
	Safe Network Connections	●		●
	Transit Connections	●		●
	Travel Time		●	●
 Equity	Serves Disadvantaged Communities	●		●
	Access to Desired Destinations	●		●
	Serves Park-Deficient Areas	●		●
 User Experience	Perceived Safety	●	●	
	Level of Comfort		●	●
	Sound and Smell	●	●	
	Visual Experience		●	
 Health	Physical Activity	●		●
	Community Gathering Places	●		●

Potential Alternatives

Using the evaluation criteria described in pages EX-22–EX-23, a series of preliminary screenings were conducted to help identify five potential alternatives that responded best to the project goals. The five potential alternatives were also scored on how well they responded to community preferences on access points and path types. The five potential alternatives can be seen in Figure 12.

The top five potential alternatives have a number of key similarities. They have similar lengths (7.93 to 8.12 miles), number of crossings (5 to 7), and access points (10 to 12). All alternatives connect to key access points such as Los Angeles State Historic Park/Main Street, Mission Road/Cesar Chavez Avenue, Union Station, and Washington Boulevard. These key access points performed well with the goals, responded to the public input, and had no suitable alternatives.

The five screened alternatives feature a number of subtle but key differences. Each performs well with the goals, but in different ways and to different degrees. Each alternative has a unique combination of path types, crossings, and access points.

Crossings occur in different locations in order to provide access to a unique combination of access points. Variation in access points occur in locations where several suitable alternatives exist, such as between 1st Street West and 1st Street East.

Each potential alternative also features future opportunities for path alignments and access points. Future opportunities go beyond the current budget of the project and provide design alternatives that could be added over time. Informed by community input, they include providing additional access points, a channel bottom path, and a parallel east side path loop in the northern reach of the project corridor.

Of the top five screened alternatives, three alternatives were selected for environmental review. In May 2019, the project team presented these three top-performing path alternatives at a PDT meeting, a stakeholder roundtable, and three community open house meetings. Overall, PDT members and community members at all four events were supportive of the alternatives. Summaries of the evaluation results and community feedback on the path alternatives can be found in Chapters 9 and 10.

Figure 12. Top Five Potential Alternatives

Alternatives A, B, and C were selected for environmental review

- West Bank
- East Bank
- Existing Path
- Future Opportunity

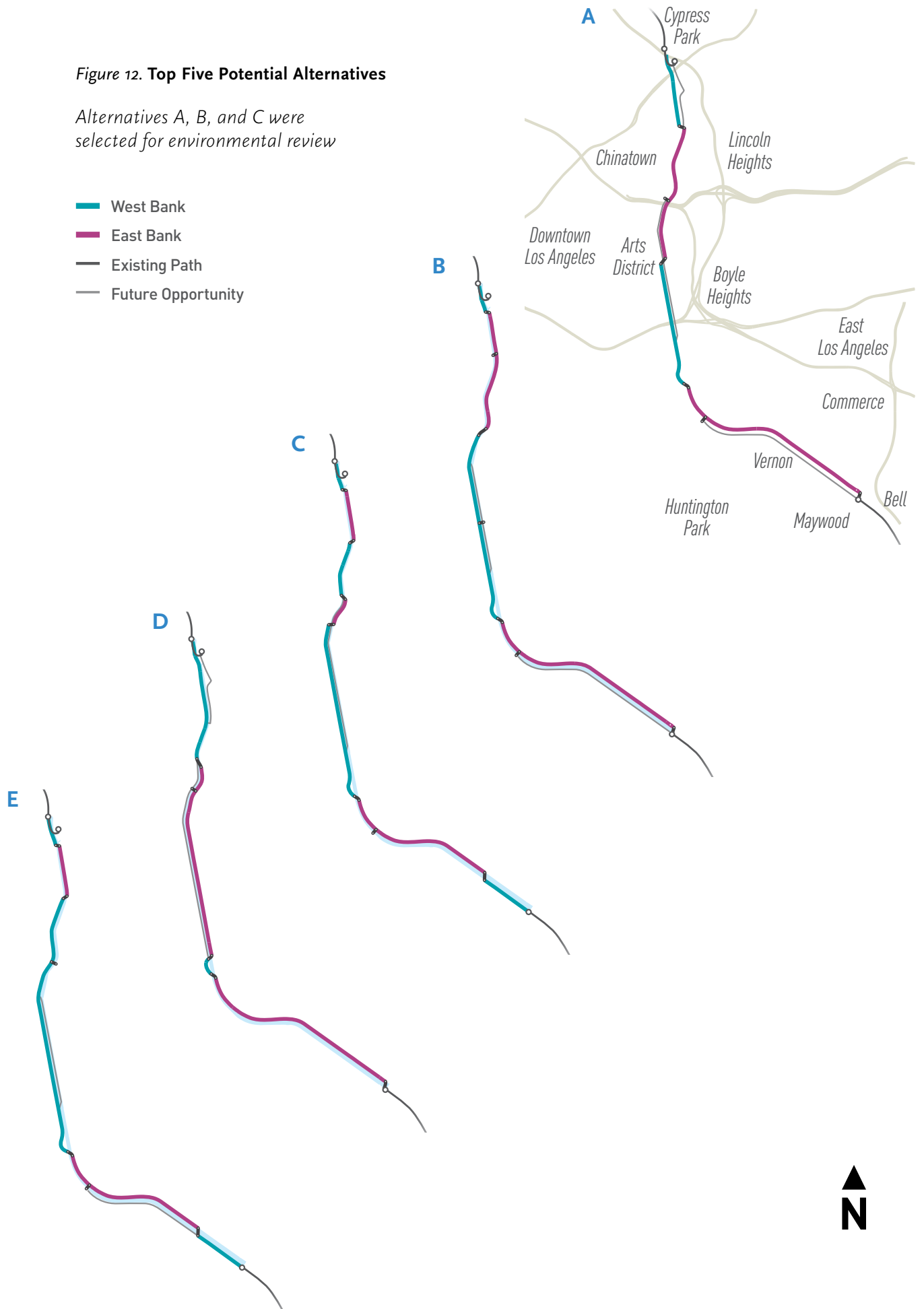

PATH ALTERNATIVES

Community Benefits

933,000+ residents served 
access to **629,000+** jobs 

*Based on a three mile radius of proposed access points.
These are representative numbers for all three path alternatives.*

Overview

Alternatives A, B, and C performed highest because they responded best to the project goals and the public input. The path alternatives reinforce the project goals, and within three miles of proposed access points, will serve 933,574 residents and provide access to 629,215 jobs.

Alternatives Similarities

Alternatives A, B, and C feature a number of design similarities. First, they all start and end on the west bank to connect to the existing paths. Second, the alternatives use a combination of three path types (elevated, top-of-bank/cantilevered, and incised) and cross the river to utilize both sides of the river bank. They also feature the opportunity for a future bottom-of-channel loop between Union Station and Olympic Boulevard and in Vernon. In one highly constrained area, north of Redondo Junction, all alternatives utilize the west bank because the east bank is not a constructible option. Finally, Alternatives A, B, and C provide access to destinations that were rated highly by the community which include:

- **Los Angeles State Historic Park/Main Street Access:** Provides access to regional parks and serves as the gateway to Chinatown.
- **Albion Park/Main Street Access:** Provides access to a local recreation center and serves as the gateway to Lincoln Heights.
- **Mission Road/Cesar Chavez Avenue Access:** Serves major employment connections, both Lincoln Heights and

Boyle Heights, and has potential for a community gathering space.

- **Union Station Access:** Provides the most access to employment and transit connections of any access point.
- **Washington Boulevard Access:** Breaks up a long stretch of the path without access and serves connections to the Blue Line.
- **Bandini-Soto Triangle Access:** Connects to a key commercial hub and serves major employers in Vernon.
- **Downey Road East Access:** Breaks up a long stretch of the path without access and serves major employers in Vernon.

Unique Characteristics

The three alternatives vary in their combination of path types and access points. The path types seen in the alternatives respond to site conditions in different ways. For example, Main Street is an at-grade bridge. Two alternatives (B and C) cross over Main Street while one alternative (A) passes under Main Street. In addition, the way in which alternatives connect to key destinations results in different user experiences. An example is connecting to 1st Street. Two alternatives connect to the 1st Street on the east bank (A and C) and one alternative (B) connects on the west bank. Key features, cost estimates, and maps for the three alternatives are found on the following pages.

ALTERNATIVE A

Key Features

Alternative A has the most consistent path type of the three alternatives, with the fewest river crossings and fewest transitions between path types. Key features include:

- **Future Loop:** Future opportunity to expand access with a northern loop between Figueroa Street and Albion Park.
- **1st Street East:** Path provides direct access to Mission Road and 1st Street near Mendez High School.
- **Downtown Crossing:** Path crosses the river near 4th Street, providing future access opportunities on both sides of the river.
- **7th Street Access:** Top-of-bank path between 4th Street and Olympic Boulevard enables Arts District access at 7th Street as opposed to 6th Street Tunnel.
- **Future Bottom-of-Channel Path:** Future opportunities between Union Station and Olympic Boulevard and between Bandini-Soto and Atlantic Boulevard.

RESPONSE TO PUBLIC INPUT

- Alternative A is 48% top-of-bank path, the most desired path type.
- 7th Street was the most desired access point between 4th Street and Olympic Boulevard.
- Future access opportunities at 4th Street bridge, Arroyo Seco, and 6th Street Tunnel, all top rated access points.

Path Statistics

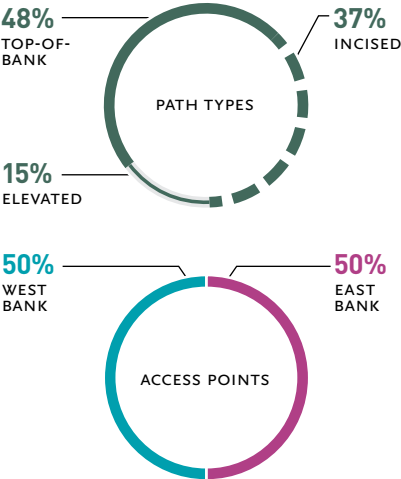

7.93
MILES

6
CROSSINGS

10
ACCESS POINTS
5 EAST BANK
5 WEST BANK

Transit Access

Which Metro Stations are served?

- **Union Station** ●●●●●
- **Chinatown** ●
- **Pico / Aliso** ●
- **Washington Bl** ●

Cost Estimate

What is the estimated cost for this alignment and how is it distributed?

Hard costs	\$216M - \$305M
Soft costs	\$83M - \$98M
Project Contingency	\$30M - \$40M
Total Cost	\$329M - \$443M

*based on 2019 values.

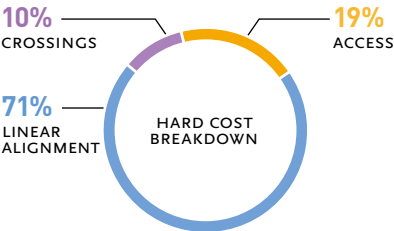

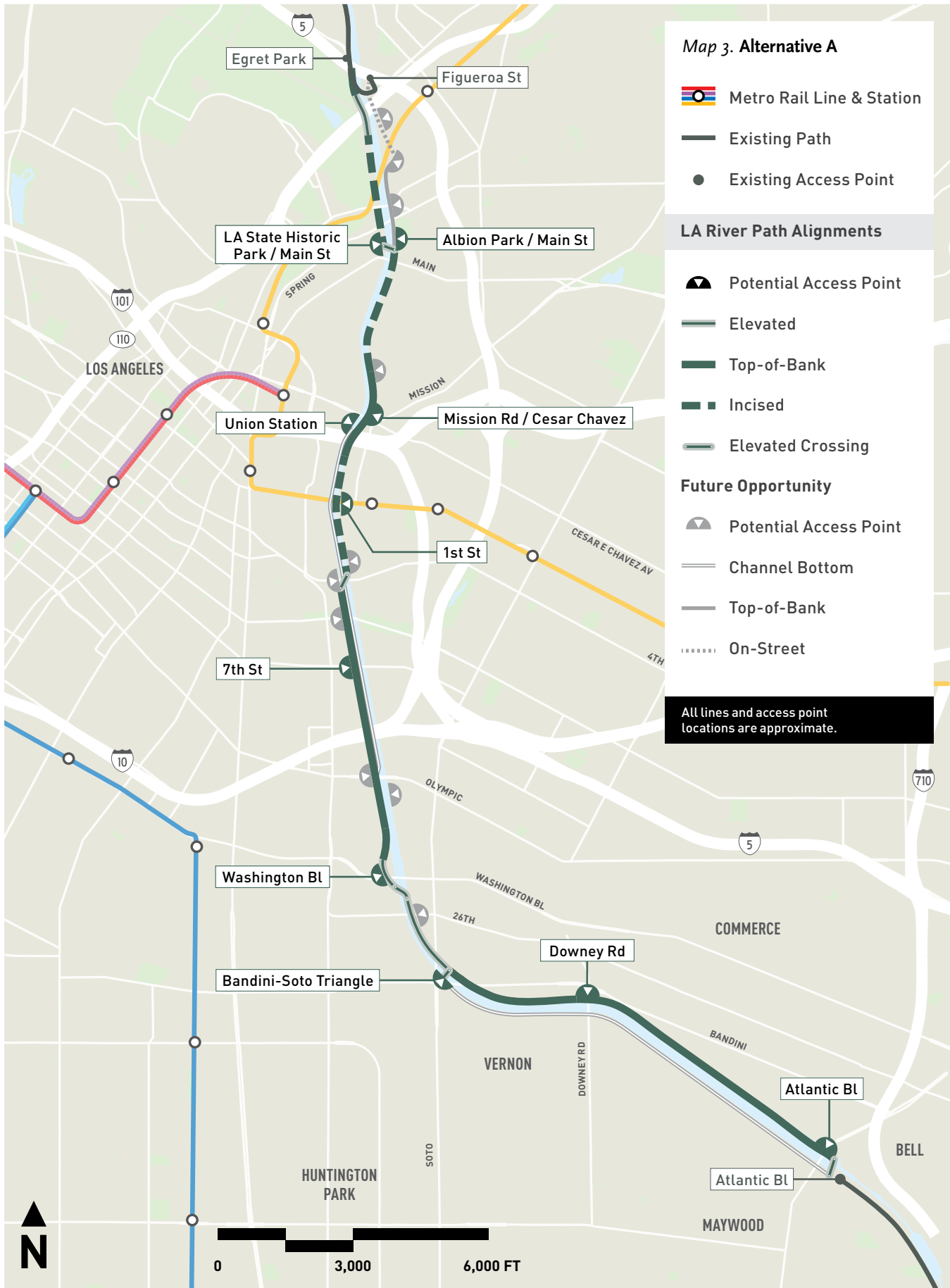

0 3,000 6,000 FT

ALTERNATIVE B

Key Features

Alternative B has the most access points of the three alternatives, with the most connections to parks and to downtown Los Angeles. Key features include:

- **Parks Confluence:** Path provides access to Albion Park, Los Angeles State Historic Park, and Ed Reyes Greenway.
- **Union Station:** Path provides a direct connection between Cesar Chavez Avenue and Union Station.
- **1st Street West:** Path provides Little Tokyo access at 1st Street bridge.
- **7th Street/6th Street Park:** Path provides a crossing and access point at 7th Street / 6th Street Park.
- **Future Bottom-of-Channel Path:** Future opportunities between Union Station and Olympic Boulevard and between Bandini-Soto and Atlantic Boulevard.

RESPONSE TO PUBLIC INPUT

- From the northern terminus through 1st Street Alternative B is elevated and top-of-bank, the top two desired path types.
- Mission Road/Cesar Chavez Avenue and Union Station were the top rated access points for people who want to commute.
- Future access opportunities at 4th Street bridge and Arroyo Seco, both top rated access points.

Path Statistics

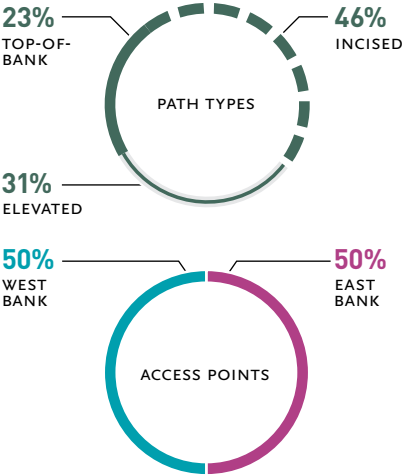

8.02
MILES

7
CROSSINGS

12
ACCESS POINTS
6 EAST BANK
6 WEST BANK

Transit Access

Which Metro Stations are served?

- Union Station ●●●●
- Chinatown ●
- Lincoln / Cypress ●
- Little Tokyo / Arts District ●
- Washington Bl ●

Cost Estimate

What is the estimated cost for this alignment and how is it distributed?

Hard costs	\$265M - \$366M
Soft costs	\$92M - \$109M
Project Contingency	\$36M - \$48M
Total Cost	\$393M - \$523M

*based on 2019 values.

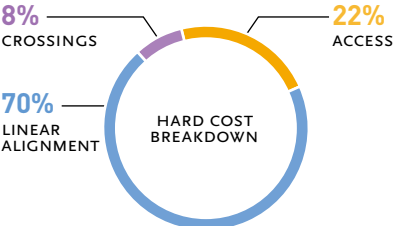

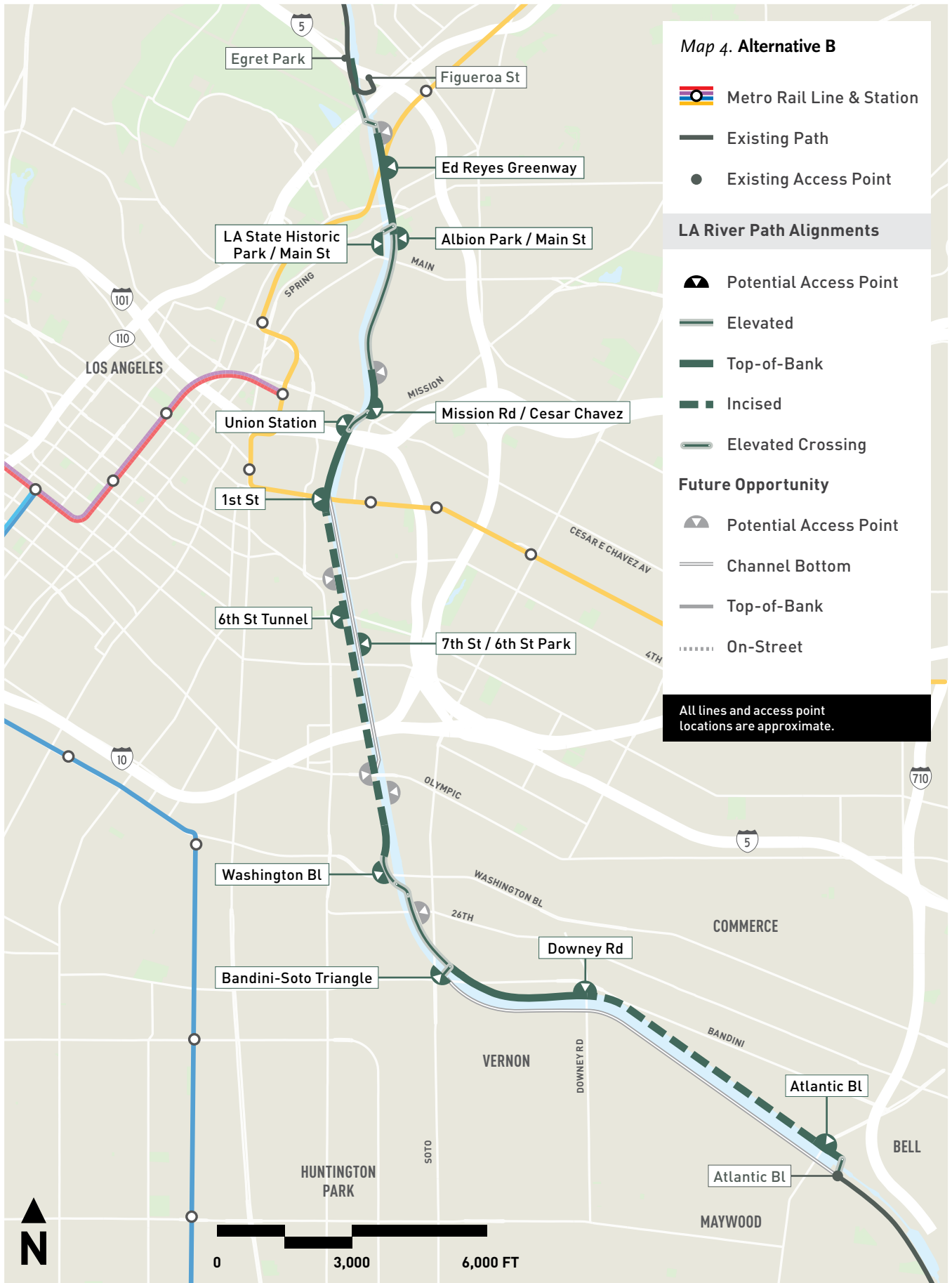

ALTERNATIVE C

Key Features

Alternative C has the most seamless and direct connections between access points and between the east and west side of the river. Key features include:

- **Lincoln Heights Connections:** Path passes through Lincoln Heights providing access to Ed Reyes Greenway, Broadway / Spring Street, and Albion Park.
- **Union Station Confluence:** Elevated path provides direct connections between 1st Street East, Union Station, and Mission Road / Cesar Chavez Avenue.
- **6th Street Tunnel:** Path provides Arts District access at the 6th Street Tunnel.
- **District Crossing:** Path crosses the river between Downey Road and Atlantic Boulevard to provide a future access opportunity at District Boulevard.
- **Future Bottom-of-Channel Path:** Future opportunities between Union Station and Olympic Boulevard and between Bandini-Soto and Atlantic Boulevard.

RESPONSE TO PUBLIC INPUT

- Alternative C is 59% of combined top-of-bank and elevated path, the top two desired path types.
- 1st Street west was a top rated access point.
- Future access opportunities at Arroyo Seco and William Mead Homes, two top rated access points in the north.

Path Statistics

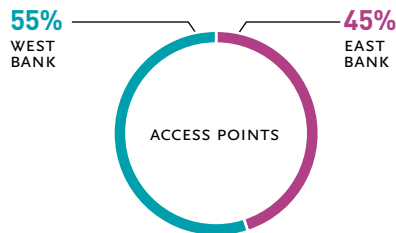
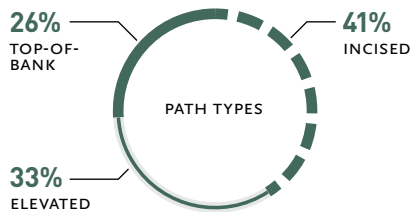

8.12
MILES

7
CROSSINGS

11
ACCESS POINTS
6 EAST BANK
5 WEST BANK

Transit Access

Which Metro Stations are served?

- **Union Station** ●●●●
- **Chinatown** ●
- **Lincoln / Cypress** ●
- **Pico / Aliso** ●
- **Washington Bl** ●

Cost Estimate

What is the estimated cost for this alignment and how is it distributed?

Hard costs	\$218M - \$307M
Soft costs	\$84M - \$99M
Project Contingency	\$30M - \$40M
Total Cost	\$332M - \$446M

**based on 2019 values.*

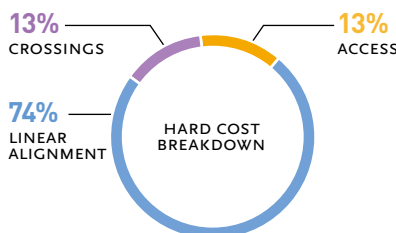

Map 5. Alternative C

 Metro Rail Line & Station

 Existing Path

 Existing Access Point

LA River Path Alignments

 Potential Access Point

 Elevated

 Top-of-Bank

 Incised

 Elevated Crossing

Future Opportunity

 Potential Access Point

 Channel Bottom

 Top-of-Bank

 On-Street

All lines and access point locations are approximate.

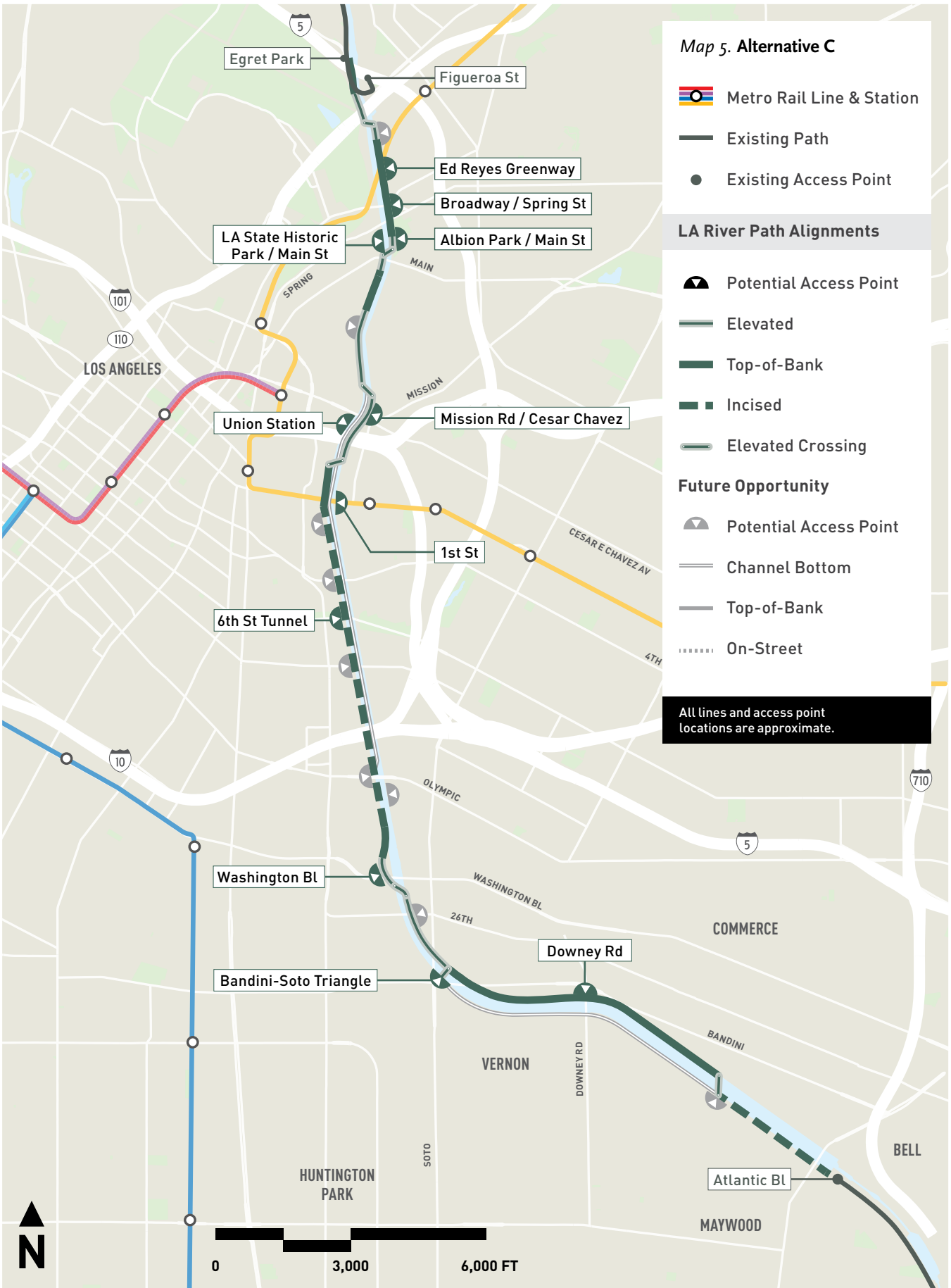

NEXT STEPS

Environmental Process and Conceptual Engineering

To construct the path, Metro is required to complete a state environmental review (CEQA), which will include evaluation of up to three path alternatives. Federal environmental review (NEPA) will also be required because of potential impacts to the Los Angeles River under the jurisdiction of the USACE, a federal agency.

The environmental review will include in-depth study of the three alternatives' potential impacts and benefits on a range of topics, including but not limited to socioeconomic, historic resources, and traffic.

The alternatives for environmental review will be studied and evaluated based on conceptual-level engineering and related technical and environmental information, along with public and stakeholder input.

This technical analysis of each alternative will focus on considering potential impacts, and will involve the public and stakeholders in the evaluation. The purpose of the final screening step is to provide sufficient information needed to identify a locally preferred alternative (LPA).

Following the Final Environmental Impact Report (FEIR), the project will seek a series of approvals from various federal, state, and local agencies as part of the permitting process.

The alternatives and options will continue to be modified and narrowed based on ongoing discussions with project partners, public input, and through the environmental process.

Design of the path including aesthetics and path amenities will continue into the next phase of the project and will be included in ongoing community engagement. Metro will work with stakeholders and community members to ensure artwork opportunities and artwork designs are integrated into the project. With a focus on creating a world-class user experience, design themes and elements will be incorporated during environmental review and further design.

Photos, opposite:

18. The Cycle Snake (Cykelslangen), Copenhagen, Denmark

19. Tongva Park, Santa Monica, CA

20. This Way, Linnaea Tillet and Karin Tehve, Artists, under the Brooklyn Bridge, New York, NY

21. Kalvebod Waves, Copenhagen Harbour, Denmark

22. Vistula Boulevards, Warsaw, Poland

23. University of Texas, El Paso, TX

24. "Under LA" by Refik Anadol + Peggy Weil, commissioned by Los Angeles Department of Current Affairs, Los Angeles, CA



18

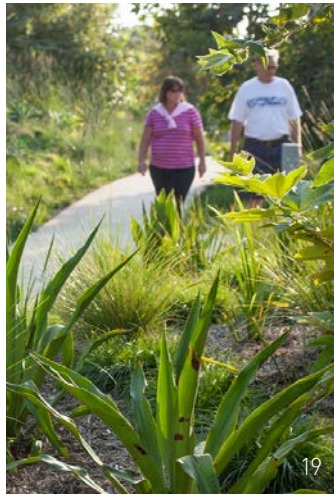

19



20



22



23



24



01

PROJECT OVERVIEW

Why is this important?

This project will close the longest remaining gap in the existing LA River Path, connecting Elysian Valley and the City of Maywood through downtown Los Angeles. Designed to serve all ages and abilities, the LA River Path will benefit the communities surrounding the Los Angeles River, providing them with a safe and reliable active transportation corridor.



How does it apply to the LA River Path?

Chapter 1 provides an overview of the LA River Path project, including the project mission and goals, a profile of the expected path users, and a brief overview of the estimated path benefits.

PROJECT OVERVIEW

Overview

The LA River Path project will design and construct an approximately 8-mile walking and bicycling path along the Los Angeles River between Elysian Valley and the City of Maywood through downtown Los Angeles (see Map 6). The project will close the longest remaining gap in the LA River Path to serve existing communities and meet future demand. When complete, this facility will provide a seamless 32-mile grade-separated regional corridor for walking, rolling, and bicycling from the San Fernando Valley to Long Beach along the Los Angeles River.

Metro, along with a number of local and regional organizations, has long identified closing the gap in the LA River Path between Elysian Valley and Maywood as a high-priority walking and bicycling infrastructure project, including the 2016 Metro Active Transportation Strategic Plan, the City of Los Angeles Mobility Plan 2035, City of Vernon Bicycle Master Plan, and the 2016 Metro LA River Bike Path Gap Closure Feasibility Study.

There are multiple project phases that will occur before the path can open in 2027. In Phase I (see Figure 13), the project team worked through conceptual design, which included technical studies to learn more about the corridor's existing conditions, and outreach to understand the community's needs and desires. As part of this process, path alternatives were developed that can overcome the physical and regulatory challenges identified throughout the corridor and best serve the community's needs. These alternatives will be further studied during Phase II.

Phase II will begin in late 2019 and will take the project through the environmental clearance process and identify a locally preferred alternative (LPA). During Phase III, the project will progress through final design, permitting, and real estate. Construction is scheduled to begin during Phase IV, as early as 2023.

Figure 13. Project Timeline



Map 6. LA River Path Project



PROJECT MISSION AND GOALS

Development of Mission and Goals

The LA River Path project is driven by a mission statement and goals, which were shaped early in the planning process by project stakeholders and the community through the public engagement process. Throughout the community engagement process, the mission statement and goals were refined to ensure they captured the intent and desires of the community.

Several consistent themes emerged from the outreach process:

- Create a great user experience
- Make the path safe
- Desire to use path for recreation/commuting
- Provide access to transit, jobs, and key destinations







These themes were incorporated into the project mission statement and goals, which provide a framework that will carry forward into the next phase of the project.

Mission Statement

Create a safe and world-class active transportation corridor along the Los Angeles River between Elysian Valley and Maywood for people of all ages and abilities that enhances recreation, livability, regional connectivity and provides:

- *An outstanding user experience*
 - *Access to opportunity*
 - *Separation from vehicular traffic*
-

Goals

	Safety	Create a path that improves safety from existing conditions.
	Access	Create a path that increases access from local neighborhoods to employment centers, regional destinations, resources, and amenities, including healthcare services.
	Efficient and Sustainable Mobility	Create a path that reduces vehicle miles traveled by allowing people to walk and bicycle in a low-stress environment through and within Los Angeles County, reducing trip lengths, and expanding travel choices.
	Equity	Create a path that improves access to opportunity for historically under-invested communities, especially in low-income communities of color.
	User Experience	Create a path that feels safe, comfortable, and is activated by the people who are drawn to it, because it is a world-class transportation corridor.
	Health	Create a path that inspires physical activity and opportunities for healthy choices in everyday life.

PATH USERS AND BENEFITS

Path Users: Who Will Use The Path?

ALL AGES AND ABILITIES

A path designed for users of all ages and abilities is one that is safe and comfortable to a wide range of people, regardless of age, ability, gender, race, or socioeconomic status. An all ages and abilities facility will attract a wider variety of users, including older adults and children, than a traditional bicycle lane or walking path.

PEOPLE WALKING

The term “pedestrians” is used inclusively here to include people walking, running, pushing strollers, and those using mobility devices such as wheelchairs. Pedestrians may take trips for recreational purposes, such as to get exercise or enjoy nature, or may travel for transportation or to access transit.

PEOPLE ROLLING

Rolling refers to people riding skateboards, rollerblading, rollerskating, and pushing vendor carts. People rolling may utilize these devices for recreation or transportation. People may use rolling to connect to or supplement a transit trip.

PEOPLE BICYCLING

People may ride a bicycle for a variety of reasons and trip types. Sport bicyclists, who ride for competition or for fitness, may value direct, smooth routes. Their trips originate and finish at the same location—usually home. Other people who ride a bicycle may not consider themselves as “bicyclists,” but they may use a bicycle for a variety of purposes: commuting to work, running errands, visiting friends or family, or general recreation. People may also use bicycles to access transit or as part of a longer, regional trip.

Nationally, only about 1% of the public uses a bicycle for transportation, in part due to concerns about safety in traffic. National surveys indicate that up to 60% of the public would ride a bicycle for some or all of their trips if concerns about traffic safety were addressed. This large group of potential and likely people who would ride a bicycle given the right conditions are referred to as “Interested but Concerned.”¹

¹ “Four Types of Cyclists,” Roger Geller, Bicycle Coordinator, City of Portland Bureau of Transportation, 2009

PEOPLE WITH DISABILITIES

The term “people with disabilities” includes individuals with physical or cognitive impairment, as well as those with hearing or visual limitations. According to the Centers for Disease Control and Prevention (CDC), in 2016, one out of every four Americans had a disability that limits their mobility.²

Additionally, nearly everyone will experience a disability at some point in their life, whether through injury, aging, or other circumstances. Pathways that are physically separated from motor vehicle traffic, such as the LA River Path, provide a safe and comfortable place for people with disabilities to enjoy.

² “Key Findings Prevalence of Disabilities and Health Care Access by Disability Status and Type Among Adults — United States, 2016.” <https://www.cdc.gov/ncbddd/disabilityandhealth/features/kf-adult-prevalence-disabilities.html>

Path Benefits

The LA River Path can provide health, economic, environmental, transportation, and equity benefits across the project area.

While the LA River Path can benefit many residents and visitors to the Los Angeles region, those living within three miles of the path (bicycling distance) and one-half mile (walking distance) will have the most convenient access to the path, and may benefit most from its completion.

HEALTH AND ENVIRONMENTAL BENEFITS

The LA River Path may encourage a shift from energy-intensive modes of transportation, such as cars, to active modes of transportation, such as bicycling and walking. While many of the active living-related benefits of a path can be difficult to quantify — such as improved mental and physical health, educational growth, connection to nature, and sense of place — a growing body of literature links parks and trails to increased physical activity, decreased healthcare costs, and improved air quality.^{1,2,3}

The LA River Path may help to generate over 3 million more bicycling and walking trips per year, resulting in a reduction of over 2 million pounds of pollutants from the atmosphere each year.

TRANSPORTATION COST BENEFITS

With fewer vehicle trips and more bicycling and walking trips, residents may benefit from the reduced costs associated with congestion, collisions, road maintenance, and gas. The project may help prevent collisions between people driving and people walking or bicycling, providing savings in avoided collision costs. The LA River Path may also lower household transportation expenses for residents within the assessment area because bicycling and walking are the lowest cost transportation options.

Finally, the LA River Path may help Metro and regional partners meet their goals for greenhouse gas reductions. It is estimated that the LA River Path may lead to 27.2 million fewer vehicle miles traveled (VMT) over 20 years.

1 *State Indicators Report on Physical Activity*, CDC. (2014) www.cdc.gov/physicalactivity/downloads/pa_state_indicator_report_2014.pdf

2 *Inadequate Physical Activity and Health Care Expenditures in the United States*. www.cdc.gov/nccdphp/dnpao/docs/carlson-physical-activity-and-healthcareexpenditures-final-508tagged.pdf

3 *The Economic Benefits of the Public Park and Recreation System in the City of Los Angeles, California*, The Trust for Public Land (2017) https://trails.lacounty.gov/Files/Documents/125/CA_LA%20Economic%20Benefits%20Report_LowRes.pdf



26. Los Angeles River Greenway Trail, Los Angeles, CA

27. Lime Scooter, Santa Monica, CA

28. Los Angeles Walk to School Day, Los Angeles, CA



02

PROJECT CONTEXT

Why is this important?

Today, the Los Angeles River is a vital resource for the diverse communities that live near and along its banks, who use the river for a range of daily and recreational activities that include bicycling, walking, skating, fishing, kayaking, photography, bird watching, and community gathering. The future of the Los Angeles River is now being planned, with a major component of the planning effort to increase active transportation along the corridor.



How does it apply to the LA River Path?

Project context provides a framework for how the LA River Path project responds to the area's history and planning efforts.

Chapter 2 provides an overview of the demographics of the area, the history of the river, the previous and current planning projects around the corridor, project partners, and an overview of implementation and operations and maintenance for the future LA River Path.

THE LOS ANGELES RIVER YESTERDAY AND TODAY

History of River Channelization

The Los Angeles River has a long history of major flood events that have impacted the direction of its flow. At one time, the Los Angeles River flowed westward and emptied into the Santa Monica Bay, a starkly different path from the one it holds today. Major flood events in 1914, 1934, and 1938 cost the City of Los Angeles millions of dollars in damages and cost many people their lives, and as a result, the United States Army Corps of Engineers (USACE) began an effort to channelize the entire corridor in 1938. To this day, flood control remains the most important function of the Los Angeles River channel.

It was not until 1990 that formal efforts were made to explore alternate uses for the river through the creation of the County of Los Angeles River Task Force. Since then, agencies and the broader community have studied and planned for a different river, one that involves restoration, recreation, active transportation, and development projects.

History of Active Transportation Near the Los Angeles River

Active transportation near the Los Angeles River dates back to the turn of the century. Opened in 1900, the California Cycleway was an elevated path built exclusively for people bicycling from Pasadena to Los Angeles through the Arroyo Seco, a tributary of the Los Angeles River at the north end of the LA River Path project corridor.¹ At its tallest point, the Cycleway stood elevated 50 feet above the Arroyo Seco Valley, making international news.

Although the full alignment was never completed, it was initially intended to span 9 miles and cross the Los Angeles River where the SR-110 (Pasadena) Freeway crosses it today. Dismantled in 1919, the California Cycleway's right-of-way became part of the Arroyo Seco Parkway (Pasadena Freeway). The Cycleway illustrates the history of bicycle innovation near the corridor and renewed investment in bicycling and walking infrastructure around the Los Angeles River.

Construction of the two existing paths directly north and south of the project corridor began in the 1980s. The Los Angeles River Bicycle Path runs 17 miles from Maywood to Long Beach and opened in 1983. The Los Angeles River Greenway Trail runs seven miles from Elysian Valley to Burbank and opened in 1997. For more information about the existing paths along the Los Angeles River, see the Mobility Connections section of Chapter 5, Existing Conditions.

Origins of the LA River Path Project

In 2014, the Los Angeles City Council and the Metro Board authorized two motions² to pursue closing the gap between the two existing paths along the Los Angeles River, and in 2016, Metro identified the LA River Path as one of the first projects to receive funding from Measure M.

¹ "California Cycleway was scuppered by cars" <http://roads werenot built for cars.com/californiacycleway/>
"An 1899 Plan to Build a Bike Highway" <https://gizmodo.com/an-1899-plan-to-build-a-bike-highway-in-los-angeles-an-1699592512>

² Metro Planning and Programming Committee, Motion on the Los Angeles River Bikeway Connection, June 18, 2014
City of Los Angeles, City Council Transportation Committee, Motion on In-Channel Downtown Los Angeles River Bike Path, June 2014

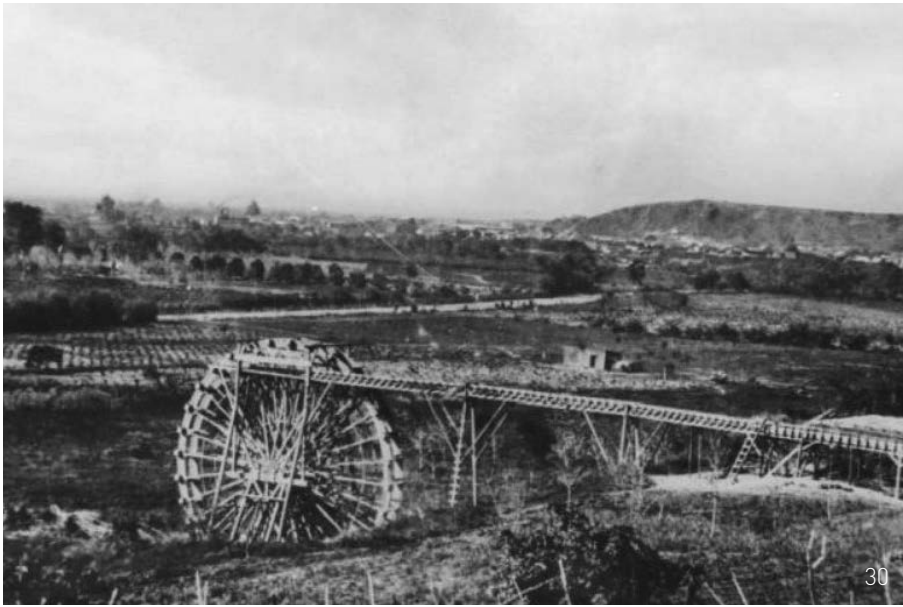

30

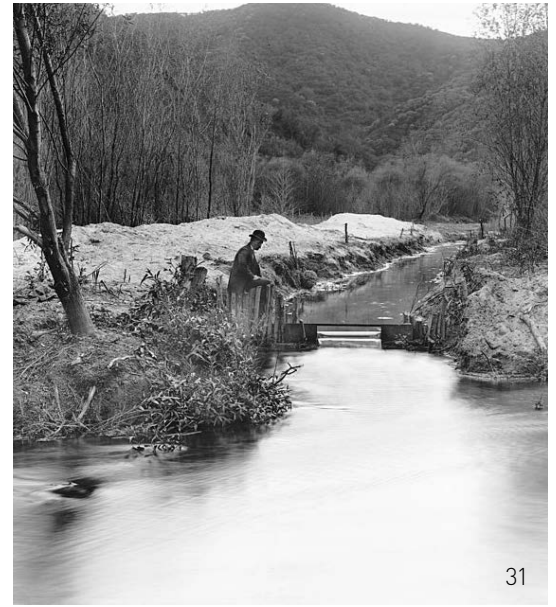

31



32



33



34



35

30. A water wheel at the start of Zanja Madre, Los Angeles' original aqueduct

31. Los Angeles River at Griffith Park before channelization

32. A house falls into the Arroyo Seco, near the confluence of the Los Angeles River below N Figueroa Street

33. Flood of 1938; Los Angeles, CA

34. Elevated Cycleway connecting Pasadena and South Pasadena, CA

35. Arroyo Seco Cycleway connecting Los Angeles and Pasadena, CA

Previous Plans

Many plans and studies conducted in the past three decades have looked at various aspects of revitalizing the Los Angeles River watershed, from open space creation to active transportation.

Most notable for this project are Metro's 2016 Los Angeles River Bike Path Gap Closure Feasibility Study and the City of Vernon's 2018 LA River Path Feasibility Study.

A number of plans have mentioned a continuous path along the Los Angeles River to be a priority active transportation infrastructure project for Los Angeles County. They include:

Los Angeles County LA River Master Plan (1996) recommended creating a continuous trail system along the entire Los Angeles River.

City of Los Angeles Los Angeles River Revitalization Master Plan (2007) envisioned a continuous bikeway along the full length of the Los Angeles River to be one of many projects that would work toward the Plan's revitalization goals of improving public space and enhancing community access to the Los Angeles River.

City of Los Angeles Bicycle Plan (2010) recommended a continuous bicycle path along the south and west sides of the Los Angeles River.

Los Angeles County Bicycle Master Plan (2012) recommended building a bicycle path along the Los Angeles River through Vernon.

Metro Active Transportation Strategic Plan (2016) included the Los Angeles River Bikeway Gap Closure Feasibility Study as a potential future active transportation infrastructure project.

Mobility Plan 2035 (2016) recommended completing a bicycle path along the Los Angeles River through downtown Los Angeles by 2025.

LA River Bike Path Gap Closure Feasibility Study (2016) found that closing the gap is feasible and would help serve the transportation needs of communities neighboring the project corridor, as well as the region.

City of Vernon LA River Path Feasibility Study (2018) provided recommendations for a path through the complex and constrained three-mile stretch through Vernon.

Lower Los Angeles River Revitalization Plan (2018) recommended a number of potential revitalization opportunities for the Lower Los Angeles River, including a multi-use path along the river in the City of Vernon.

Other Notable Plans and Projects

The Los Angeles River corridor is changing rapidly through projects initiated by several different agencies, communities, and developers. The Notable Plans and Projects map (see Table 2 and Map 7) contains an inventory of the many relevant projects completed or underway in the corridor in 2019.

The community's vision for the future of the Los Angeles River is forward thinking, with the river as something to celebrate and protect. The USACE is leading the Los Angeles River Ecosystem Restoration Project with a purpose to restore 11 miles of the river from Griffith Park to downtown Los Angeles. Federal funds in the amount of \$1.3 billion were allocated to implement this plan, marking a significant milestone in the future of a forward thinking Los Angeles River corridor that opens access for the community.

New development adjacent to the river will bring activity and new landmarks to the area through the City of Los Angeles' River Improvement Overlay (LA-RIO) District. The purpose of the LA-RIO District is to "increase awareness of, and access to, the Los Angeles River, improve the aesthetic quality of the river and its surrounding communities, increase the availability of publicly accessible open space, and effectively utilize public rights-of-way as locations to capture and treat stormwater."¹

An update to the 1996 LA River Master Plan is currently underway. Led by Los Angeles County Department of Public Works (LACDPW), the plan aims to bring a comprehensive vision to all 51 miles of the Los Angeles River. Providing "equitable, inclusive, and safe parks, open space, and trails" is one of several of its draft goals. The plan is expected to be completed in 2020.

The City of Los Angeles also has numerous active transportation improvement projects underway along the northern reach of the Los Angeles River, including four bridge projects between Glendale Narrows and downtown Los Angeles (North Atwater Bridge, Red Car Pedestrian Bridge, Taylor Yard Bike/Pedestrian Bridge, and Riverside Drive Bridge), and several miles of additional pathway to fill gaps between the existing paths along the Los Angeles River in the San Fernando Valley.

Finally, Metro is proposing the Link Union Station project to transform Los Angeles Union Station from a "stub-end tracks station" into a "run-through tracks station" with a new passenger concourse that would improve the efficiency of the station and accommodate future growth and transportation demands in the region. The project completed the Final Environmental Impact Report in June 2019 which considers connections to the future LA River Path project.

¹ cityplanning.lacity.org/Code_Studies/RIOproject/RIO_Revised/AppendixD_LA-RIOGuidelines.pdf

Table 2. Notable Plans and Projects

ID	PROJECT	ID	PROJECT
AT1	Arroyo Seco Bike Path Extension	FR1	California State Rail Plan (CSRP)
AT2	Eastside Access Bike + Ped Improvements	HW1	I-710 Corridor Project
AT3	DTLA Arts District Pedestrian and Cyclist Improvement Project	PK1	Taylor Yard G2 Parcel
AT4	Boyle Heights Pedestrian Linkage	PK2	Confluence Plaza Phase 2
AT5	Mission/Myers Roundabout Project	PK3	Albion Riverside Park (2019)
AT6	7th Street Streetscape	PK4	Piggyback Yard Feasibility Study (2013)
AT7	City of Vernon —Los Angeles River Path Active Transportation Access Plan	PK5	Hollenbeck Park Lake Rehabilitation
AT8	Rail to River Active Transportation Corridor	PK6	Sixth Street Park and Plaza
AT9	Greenway 2020 Movement	PR1	MRCA Seasonal Recreation Zone
BR1	North Atwater Bridge	PR2	Cornfield—Arroyo Specific Plan Update
BR2	Glendale—Hyperion Bridge	PR3	River Ranger Pilot Program (AB 1558)
BR3	Taylor Yard Bikeway and Pedestrian Bridge	RI1	Upper LA River Revitalization Plan
BR4	Atlantic Blvd. Bridge	RI2	LA River and Arroyo Seco Low Flow Diversion Project
D1	Bow Tie Yard Mixed Use Development	RI3	LA River Ecosystem Restoration Project
D2	1901 Blake Ave	RI3-B	LA River Ecosystem Restoration Pilot Project
D3	Lincoln Heights Jail Redevelopment	RI4	LA River Revitalization Master Plan, City of Los Angeles (2007)
D4	Elysian Park Lofts	RI5	Lower LA River Revitalization Plan (2018)
D5	Spring/Naud Street Warehouses	RI6	LA River Master Plan, Los Angeles County
D6	Consolidated Correctional Treatment Facility	TR1	Dodger Stadium Union Station Aerial Tram
D7	Metro Emergency Security Operations Center (ESOC)	TR2	Southern California Optimized Rail Expansion Program
D8	520 Mateo Project	TR3	LINK Union Station
D9	Maintenance of Way Building 20	TR4	Division 20 Portal Widening and Turnback Facility
D10	The Mesquit Project	TR5	Metro Arts District Station
D11	2136 East Violet Street	TR6	West Santa Ana Branch Transit Corridor
D12	2110 Bay	W1	Downtown Water Recycling Project
D13	Boyle Heights Sears Building	W2	Bending The River Back Into the City

Map 7. Notable Plans and Projects

LA River

PROJECT TYPES

- AT Active Transportation
- BR Bridge
- D Development
- FR Freight Rail
- HW Highway
- PK Park
- PR Program
- RI River Improvement
- TR Transit
- W Water

Projects spanning the length of the corridor

- AT9
- PR3
- RI6

See Table 2 for additional information

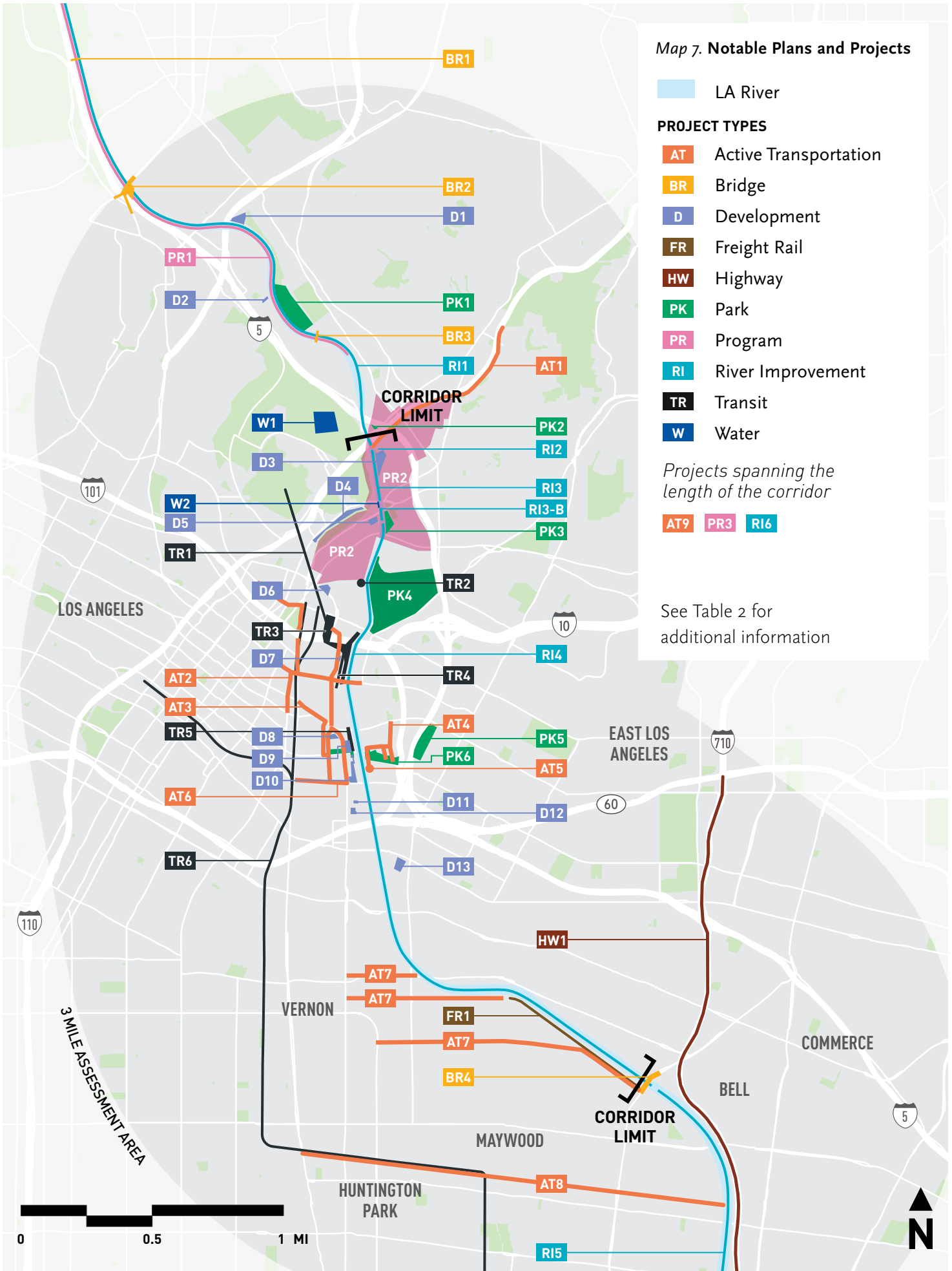

PEOPLE WHO LIVE HERE

Demographics

The LA River Path will serve the communities who live, work, and play near the corridor. Approximately one million people live within three miles of the project corridor. The median household income in this area is below the average in Los Angeles County. Existing freeways and arterial roadways bisect the neighborhoods in this area, creating health and environmental concerns. The area includes many residents who have limited access to high-quality transportation.

Residents of the area already model the travel patterns and behavior needed to create a healthier and more sustainable city, with 22% of adults not relying on private automobile ownership as their primary mode of travel.

The people who live within 1/2 mile and three miles of the river represent those who could walk and bicycle from home to the LA River Path. One half mile is considered a comfortable walking distance, while three miles is considered a comfortable bicycle ride.

Approximately 85,000 people live within 1/2 mile and 1 million live within three miles of the corridor.¹ Of the 1 million people living in the project assessment area, the majority of people are Latino (79%). Twenty-nine percent of those living within three miles live in poverty² and the median household income is \$42,600 a year. Twenty-two percent of the population rely on multi-modal transportation options for getting to work, including walking, bicycling, and taking public transit.³

¹ ACS 5 year 2016

² The U.S. government defines the federal poverty level for a family of four as \$25,000 per year. The term “low-income individual” means an individual whose family’s taxable income for the preceding year did not exceed 150 percent of the poverty level amount, approximately \$37,500 for a family of four.

³ 2017 American Community Survey 5-Year Estimate, Means of Transportation to Work

Within the LA River Path project corridor:²

85,000 

people live within walking distance of the Los Angeles River (1/2 mile)

OF THE **1** MILLION 
people who live within biking distance of the Los Angeles River (3 miles)

22% of working-age people
WALK, BIKE, or TAKE TRANSIT

Median household income is:

\$42,600

29% live in
POVERTY

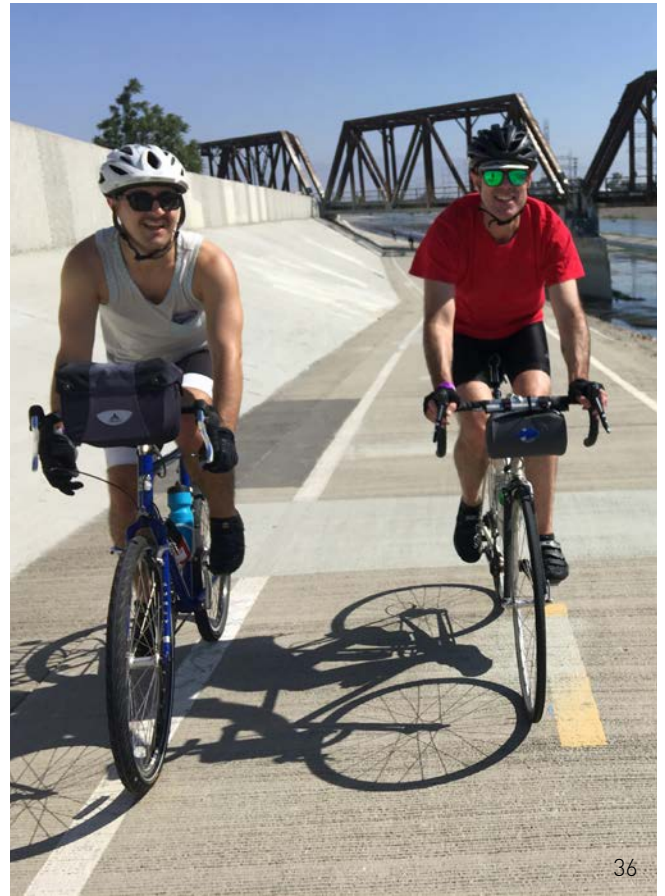
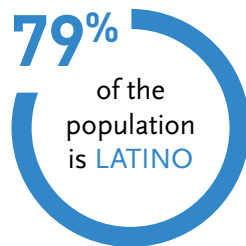

36. Los Angeles River Bicycle Path

37. Still from Metro's LA River Path Project video, February 6, 2019

38. Still from Metro's LA River Path Project video, February 6, 2019

Equity Considerations

Many communities in Los Angeles County have historically experienced inequity, or an uneven distribution of resources and gaps in access to opportunity.

Transportation facilities are essential components in creating access to opportunity. Often, historically vulnerable populations, such as older adults, people of color, people with limited English proficiency, and low-income individuals rely heavily on affordable transportation options—specifically walking, bicycling, and transit, as these are the lowest cost forms of transportation.

In February 2018, Metro adopted an Equity Platform Framework to acknowledge that access to opportunity should be a core objective of public decision making, public investment, and public service—and transportation is an essential lever to enabling that access. The equity platform provides a basis for Metro to actively lead and partner in addressing and overcoming those disparities.

Metro's Equity Platform Framework is based on four components: 1) Define and Measure; 2) Listen and Learn; 3) Focus and Deliver; and 4) Train and Grow.

Define and Measure: An equity approach recognizes that different people experience different barriers and transportation plays a major role in addressing those barriers, including mobility and access to opportunity.

Listen and Learn: An equity approach seeks to understand, through inclusive community engagement, the situations that have disadvantaged and continue to disadvantage certain communities.

Focus and Deliver: An equity approach will follow through and implement the equity platform goals and objectives.

Train and Grow: An equity approach will continue to commit to the equity platform principles in order to maximize equity advancements in Los Angeles County.

Metro is currently working to update its Long Range Transportation Plan (LRTP), and as part of that process has developed a framework to examine the connection between various demographic factors and opportunity gaps. This effort has led to Equity Focus Communities (EFCs)—communities identified as being most heavily impacted by gaps in equity in Los Angeles County. Identifying the EFCs throughout Los Angeles County will enable Metro to measure and track the future equity impacts of its transportation projects.

Equity Focus Communities

It is difficult to measure equity because it means different things to different people. Inequity, or gaps in opportunity, is easier to quantify. Demographic factors are important determinants of inequity in Los Angeles County. These factors include:

- Race (non-white);
- Income (<\$35,000 annual income);
- Age (over age 65);
- Disability (household with at least one person with a disability);
- Family structure (single-parent household);
- Car ownership (zero-car households);
- Housing tenure (renter), and
- English language (limited English household).

Of these equity risk factors, Metro's LRTP identified three factors to have the highest correlation to gaps in equity access— income, race, and zero-car households—and uses these factors to identify EFCs. The LRTP found that communities with large concentrations of low-income, non-white, and zero-car households show opportunity gaps well above the county average.

For the purposes of identifying EFCs, Metro is using the following thresholds¹:

- >40% Low Income
- >80% Non-white
- >10% Zero Car
- Meets low income and EITHER non-white OR zero car thresholds

The LA River Path project used these thresholds to identify the EFCs within three miles of the project corridor (Map 11).

Approximately 72% of the estimated population of census blocks within 1/2 mile and 67% of the estimated population of census blocks within 3 miles of the project corridor live in an EFC.²

In the northern reach of the assessment area, EFCs exist on both sides of the project corridor, meeting either one or both of the Metro combined thresholds for identifying EFCs. In the central reach, the Boyle Heights community on the east side of the project corridor is considered to be an EFC, while the downtown neighborhoods to the west of the corridor do not meet the thresholds. While the City of Vernon does have a majority non-white population, it does not meet the income or zero-car household thresholds and as such is not identified as an EFC. Vernon is nearly an exclusively industrial city and has a very small population in relation to its size. Most of the City of Maywood, however, meets all three EFC thresholds and is considered to be a community that has experienced gaps in equity and access to opportunity.

¹ Metro Planning and Programming Committee, June 19, 2019, Long Range Transportation Plan Update

² ACS 2017, 5 year

Metro's Vision 2028 Plan documents a number of goals for improving mobility in Los Angeles County over the next decade, one of which is to promote access to opportunity, including jobs, education, public health, and safety. The LA River Path project will further this goal by providing access to a safe and reliable active transportation corridor, thereby:

- Lowering the amount of household income spent on transportation costs;
- Contributing to lower greenhouse gas emissions;
- Increasing active transportation mode share;
- Increasing the number of miles of bicycle pathways within ½ miles of transit; and
- Improving access to jobs.

Through partnerships with other agencies, the LA River Path also has the potential to serve as a needed recreation and open space amenity and as a conduit for accessing other recreation areas.

Equity considerations for the LA River Path will be addressed during design and planning, as well as throughout the community engagement process, to ensure the facility planning, design, and implementation addresses the concerns of the communities the path will be serving.

Map 8. Low Income Households

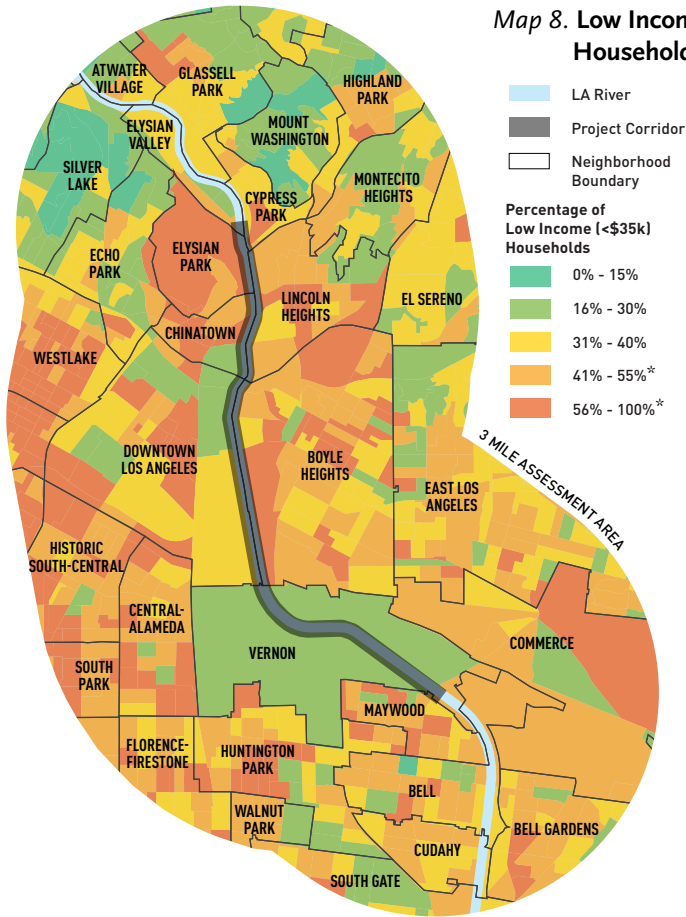

Map 10. Non-White Households

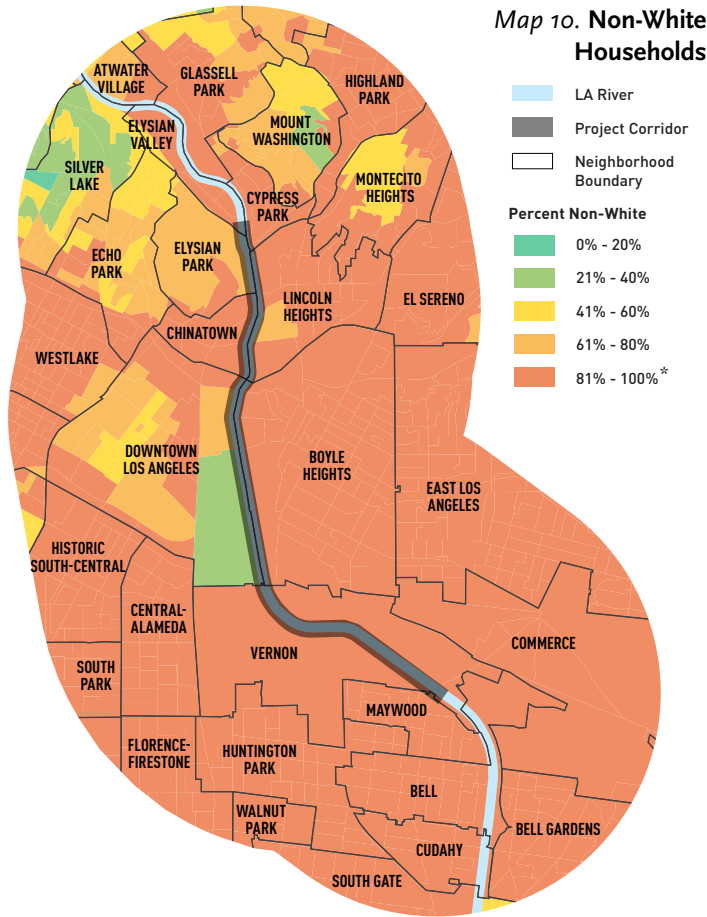

Map 9. Zero-Car Households

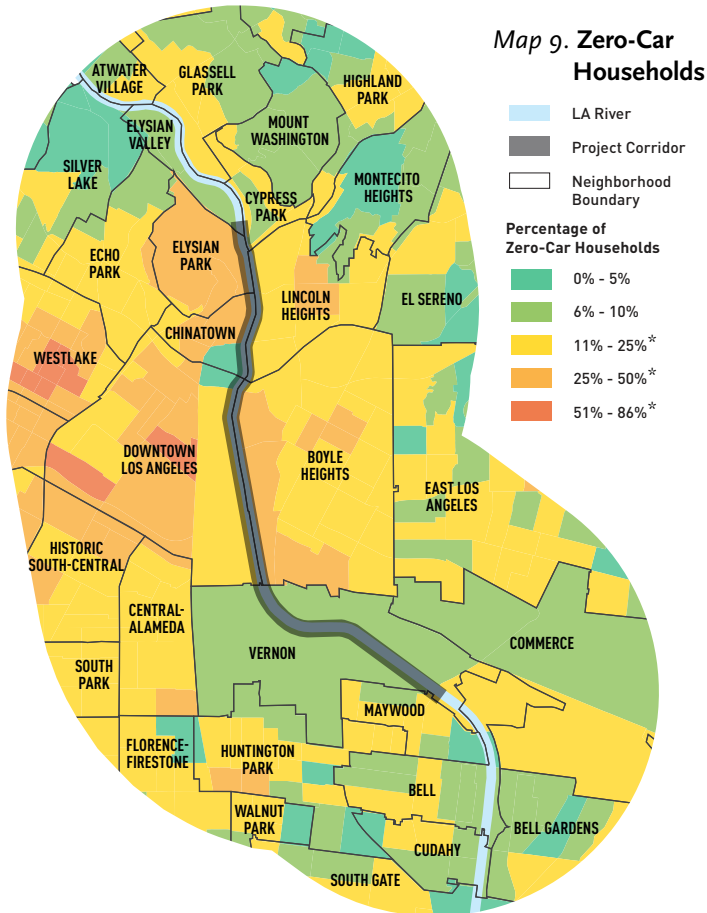

Map 11. Equity Focus Communities

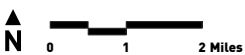
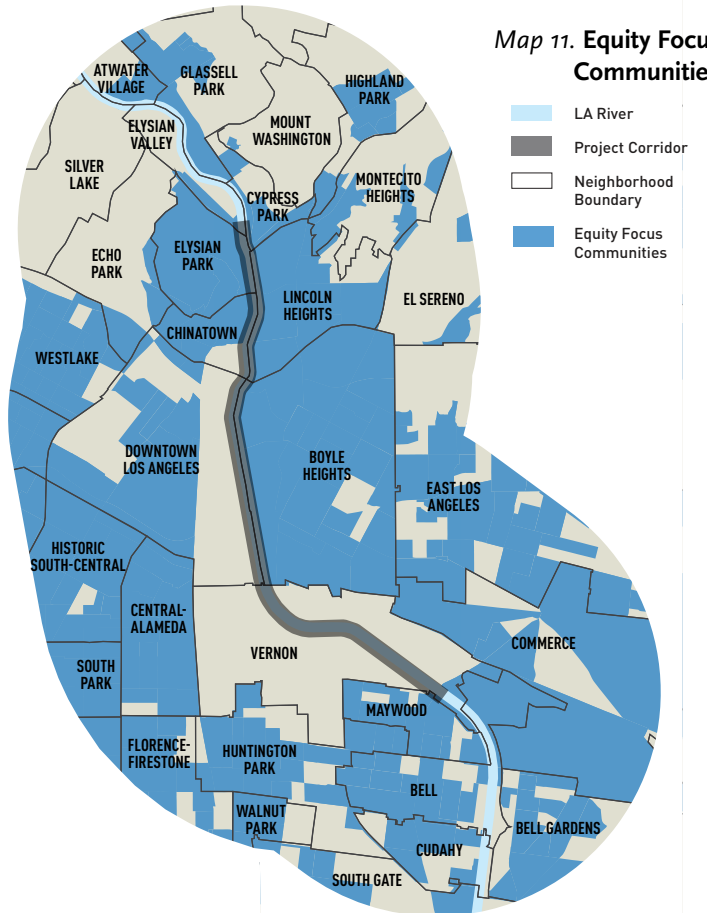

*Meets EFC threshold

PROJECT STAKEHOLDERS

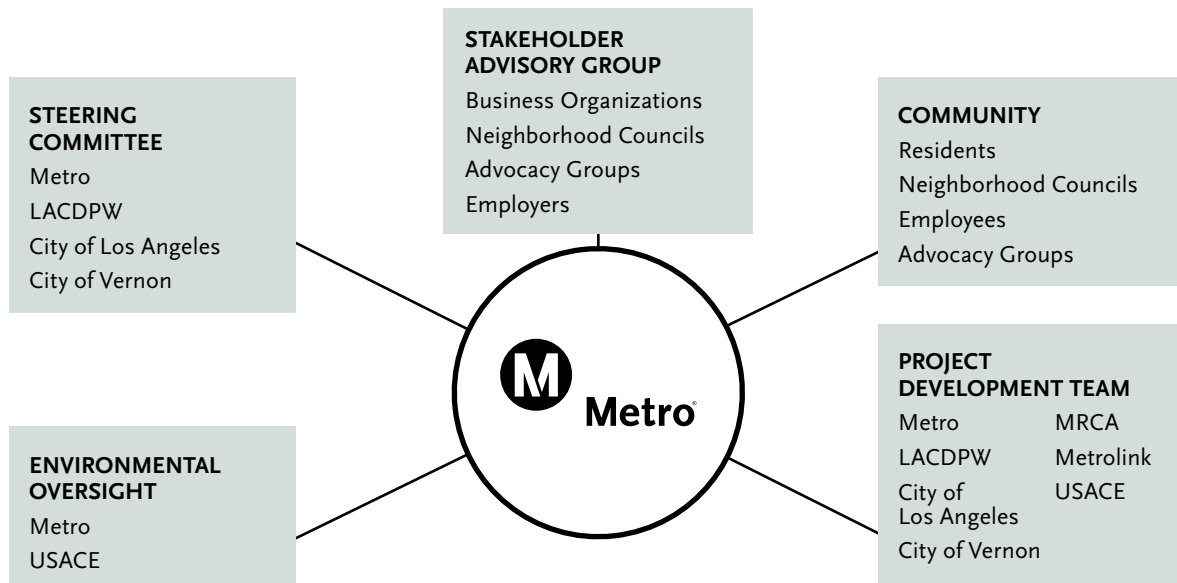

Many stakeholders and agencies are involved in the planning and development process in order to ensure the LA River Path project best meets the needs of the communities it will serve. The LA River Path project has involved extensive collaboration with several different stakeholder groups, including an environmental oversight group, a Steering Committee, a Project Development Team, a Stakeholder Advisory Group, and the community. Ongoing coordination and collaboration between these stakeholders is key for planning and designing a successful path.

The Steering Committee, comprising Metro, Los Angeles County, the City of Los Angeles, and the City of Vernon, oversees the project, provides project guidance, and supports decision-making.

Environmental oversight involves the agencies that may collaborate on environmental documentation processes such as the California Environmental Quality

Act (CEQA) and National Environmental Policy Act (NEPA). The U.S. Army Corps of Engineers (USACE) is included as an agency that will work with Metro in these efforts.

A Stakeholder Advisory Group allows business organizations, neighborhood councils, advocacy groups, and employers to share stakeholder priorities and support in project planning efforts.

A community inclusive process brings together community members and stakeholders through pop-ups, surveys, open houses, and scoping, to discuss priorities and community needs.

The Project Development Team (PDT) is made up of several agencies including Metro, USACE, the City of Los Angeles, the City of Vernon, Los Angeles County, and Mountains Recreation & Conservation Authority (MRCA). The PDT provides interagency coordination, technical guidance, and problem-solving for the project.

Photos, opposite:

- 39. Interagency coordination meeting, Los Angeles, CA
- 40. Community open house, Boyle Heights, CA
- 41. Community open house, Cypress Park, CA
- 42. Project Development Team reviewing project map



39



40



41



42

IMPLEMENTATION

LA River Path Funded through Measure M

The LA River Path is funded by Measure M, a half cent sales tax approved by Los Angeles County voters in 2016. Metro identified the 8-mile LA River Path as a “shovel ready” project, and is one of the first projects to receive funding. The Los Angeles County Transportation Expenditure Plan for Measure M identified \$365 million (in 2015 dollars without escalation) for design and construction of the core path alignment.

Permitting Process

The permitting process for the LA River Path will require a series of approvals from various federal, state, and local agencies. Table 3 describes the required permits and responsible agencies as understood currently.

Table 3. Major Permitting

PERMIT / APPROVAL	APPROVING AGENCY
Clean Water Act Section 404 and 408	United States Army Corps of Engineers
Clean Water Act Section 401	Los Angeles Regional Water Quality Control Board
National Pollutant Discharge Elimination System (NPDES) General Construction: Dewatering Permit	State Water Resources Control Board
California Fish and Game Code Section 1602: Lake or Streambed Alteration Agreement (LSAA)	California Department of Fish and Wildlife
NPDES General Industrial	State Water Resources Control Board
NPDES MS4	Los Angeles Regional Water Quality Control Board
California Endangered Species Act Section 2081: Take Permit	California Department of Fish and Wildlife
United States Endangered Species Act Section 7 Consultation	United States Fish and Wildlife Service
Section 106 of the National Historic Preservation Act (NHPA) Memorandum of Agreement	State Historic Preservation Officer
Section 4(f) Evaluation Concurrence	Owner/Operator of 4(f) Resource Impacted
Review of Plans and Approval: Work conducted on power transmission lines, pipelines and railroad crossings	Public Utilities Commission and Utility Owner/Operator
Right-of-way permit, license, easement, joint agreement, or lease for impacts to parklands	Department of Parks and Recreation
100 Year Floodplain Encroachment	Federal Emergency Management Agency, Los Angeles County Flood Control
Review of Plans and Approval: Encroachment on or across a local street	Los Angeles Department of Transportation
Review of Plans and Approval: Encroachment on or across a locally regulated structure	Los Angeles Bureau of Engineering
Review of Plans and Approval: Encroachment on local highway/freeway	California Department of Transportation
Temporary Construction Easement	Affected Property Owner, to be determined during design of the selected alternative
Encroachment Permit	Affected Property Owner, to be determined during design of the selected alternative
Maintenance Agreement	Implementing Agency of LA River Path

OPERATIONS AND MAINTENANCE PLAN

After the project is constructed, path operations and maintenance (O+M) will be important for ensuring project success. O+M refers to both the overall management and operations of the path, safety patrol, day-to-day routine and long-term maintenance.

Community members consistently report that having a safe, reliable, and well-maintained path is a key priority for path users (see page 42). Specific comments have included the importance of keeping the path clean and free of debris and ensuring path elements such as lights and trash receptacles are reliably maintained. Community members have also noted the importance that path closures during flood events or construction are appropriately communicated to the public and detours are provided. For the LA River Path, this will be achieved by developing policies and programs in an O+M Plan.

Crafting a deliberate and reliable O+M Plan for the LA River Path will be critical to achieving a successful project. A comprehensive O+M Plan for the LA River Path will be developed in a future phase of the project, before the path opens.

Developing an O+M plan for the LA River Path is complex because once constructed, it will be the first time a continuous path along the Los Angeles River will span new multi-jurisdictional boundaries. The two existing paths are currently operated and maintained by different agencies. The City of Los Angeles maintains the Los Angeles River Greenway

Trail north of the LA River Path project and the County of Los Angeles maintains the Los Angeles River Bicycle Path south of the project. (See page 87 for more information about the existing path operations and maintenance).

The O+M Plan for the LA River Path will provide guidelines and recommendations for operating and maintaining the 8-mile project corridor, while also considering possibilities for future collaboration between the entities responsible for maintaining the paths and parks along the entire 51 miles of the Los Angeles River.

As the lead agency for the planning and design of the LA River Path, Metro is helping to facilitate the development of the O+M Plan with project partners.

The O+M Plan will be guided by both the Steering Committee and the PDT and will detail the key responsibilities of the management structure, along with applicable funding mechanisms for implementation.

Table 4 presents the most commonly used management structures for existing high-profile trail projects. These examples show some of the trade-offs that need to be explored to develop the right structure for the LA River Path.

Although these structures represent different possibilities for the LA River Path, they are not mutually exclusive. A hybrid approach, particularly between a Joint Powers Authority, cooperative agreement, and/or non-profit organization, may be most appropriate for the project.

Table 4. Operations + Maintenance Structures

O+M STRUCTURE	PROS / CONS
A single governmental organization directly oversees management of path O+M.	<ul style="list-style-type: none"> + Management structure used for paths managed by a single agency. - Not conducive to multi-jurisdictional coordination.
A non-profit organization establishes an independent group to coordinate the various jurisdictions and run O+M.	<ul style="list-style-type: none"> + Able to draw funding from a larger pool of sources, including private funding. + More flexibility with program development, advocacy, and communications. - No authority of an elected body or landowner. - No dedicated funding source without assistance from local, state, or federal funding mechanisms.
A cooperative agreement may divide the responsibilities for O+M among multiple agencies.	<ul style="list-style-type: none"> + Allows for agencies to conduct path O+M within their jurisdiction, while a non-profit group or authority oversees the project vision through planning, programming, and fundraising. - Potential for inconsistent maintenance throughout corridor.
A Joint Powers Authority (JPA) , typically guided by a governing board, is a legal entity that allows two or more public agencies to jointly exercise common powers.	<ul style="list-style-type: none"> + Allows for one entity to oversee O+M over multiple jurisdictions of a complex project with cohesive implementation. + Can pursue donations and grants by establishing a non-profit. - Cost considerations for running a new entity (admin, overhead, etc.)
In a commission , governmental and non-governmental entities are part of a governing board.	<ul style="list-style-type: none"> + Stable funding source for operations from membership fees. + Can pursue donations and grants by establishing a non-profit. - Membership fees relative to population and path area, could pose challenges of unequal distribution based on widely variable population densities along the Los Angeles River corridor.
Special districts are created and funded by a community's residents to provide new or enhanced local services and infrastructure.	<ul style="list-style-type: none"> + Creates a funding stream to provide O+M services. + Provides local accountability as board members are elected by districts' voters. - Funding requires voter approval.

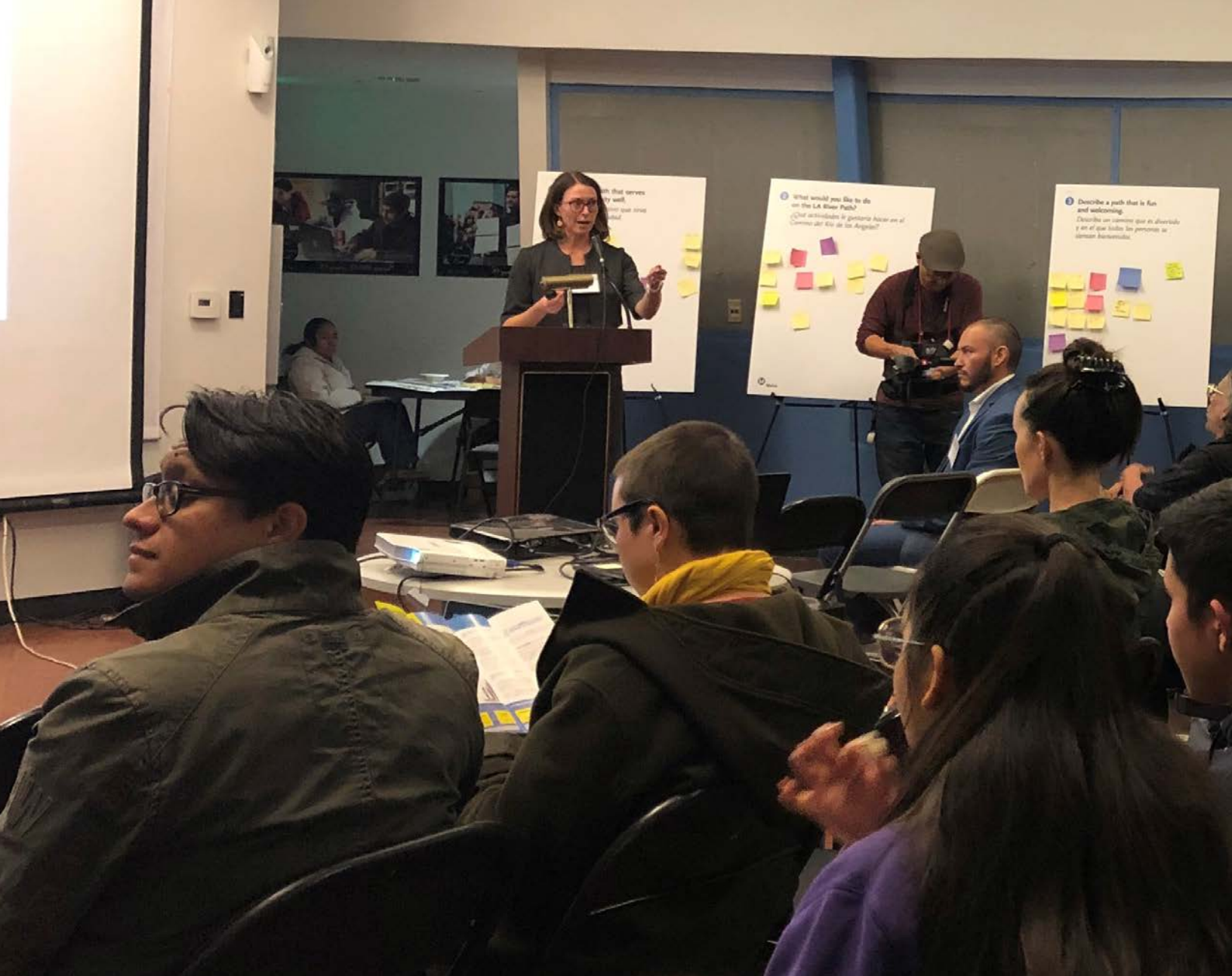

03

COMMUNITY OUTREACH

Why is this important?

This project is for the community. Understanding who lives in the area, how they travel, and where they need to go is vital in creating a path that is well used by the communities it serves.



How does it apply to the LA River Path?

Understanding community needs requires listening to community members and incorporating their ideas and concerns into the project. Extensive community input helped to shape the project mission statement, project goals, potential path types, access point opportunities, and path alternatives.

Chapter 3 provides an overview of the community engagement process, and presents community feedback on the existing river path and vision for this project, as well as the project's mission and goals.

COMMUNITY ENGAGEMENT OVERVIEW

Community input played an important role throughout the conceptual design phase of the LA River Path project, helping to inform the project mission statement, project goals, path types, and access point opportunities, all of which led to the development of three path alternatives. Figure 14 describes the community engagement process for the LA River Path project.

In an effort to better understand the communities that live in and near the assessment area, their priorities, and how the project could best meet their needs, the project team held nine community meetings and a number of other outreach events, and administered two online survey tools during the conceptual design phase. Community feedback was captured on topics such as project vision and goals, path types, and preferred access points to guide the evaluation of different potential path alternatives, and ultimately identify three top-performing path alternatives.

Overall, over 300 people participated in nine community open houses hosted over three rounds of community outreach. In addition to the community open houses, 23 pop-up events were held between August 2018 and July 2019. These events were focused on gathering input on project mission and goals, and keeping the community up to date with the project. Over 4,600 comments

Outreach Activities Between August 2018 and July 2019:

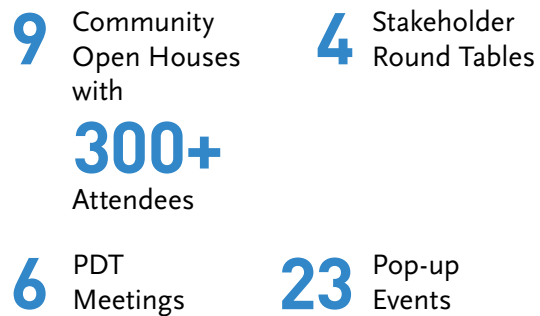

We collected



were received through all in-person events, and over 3,800 responses were received for the two online and in-person surveys. In addition, input was received from project stakeholders during stakeholder roundtables, briefings, and PDT meetings.

People participated from all over Los Angeles County, as shown in Figure 15. Map 12 illustrates how many people participated in engagement activities within the neighborhoods surrounding the project corridor. This map, which shows the number of respondents by zip code, closely corresponds to the population density of the local neighborhoods in the area.

Figure 14. Community Engagement Process

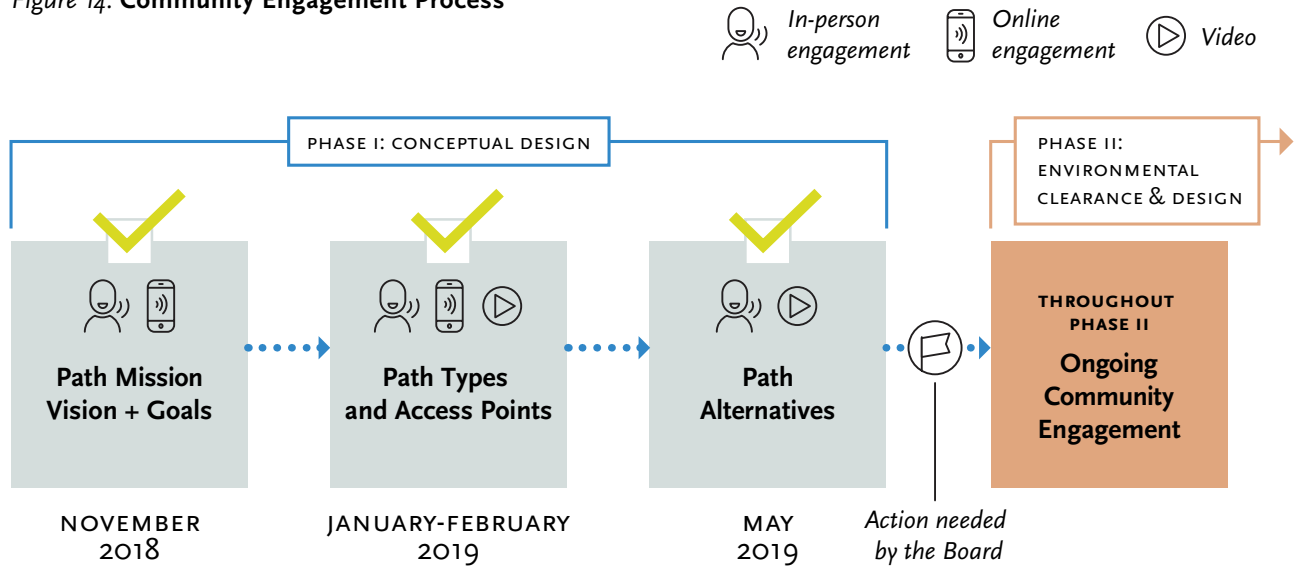
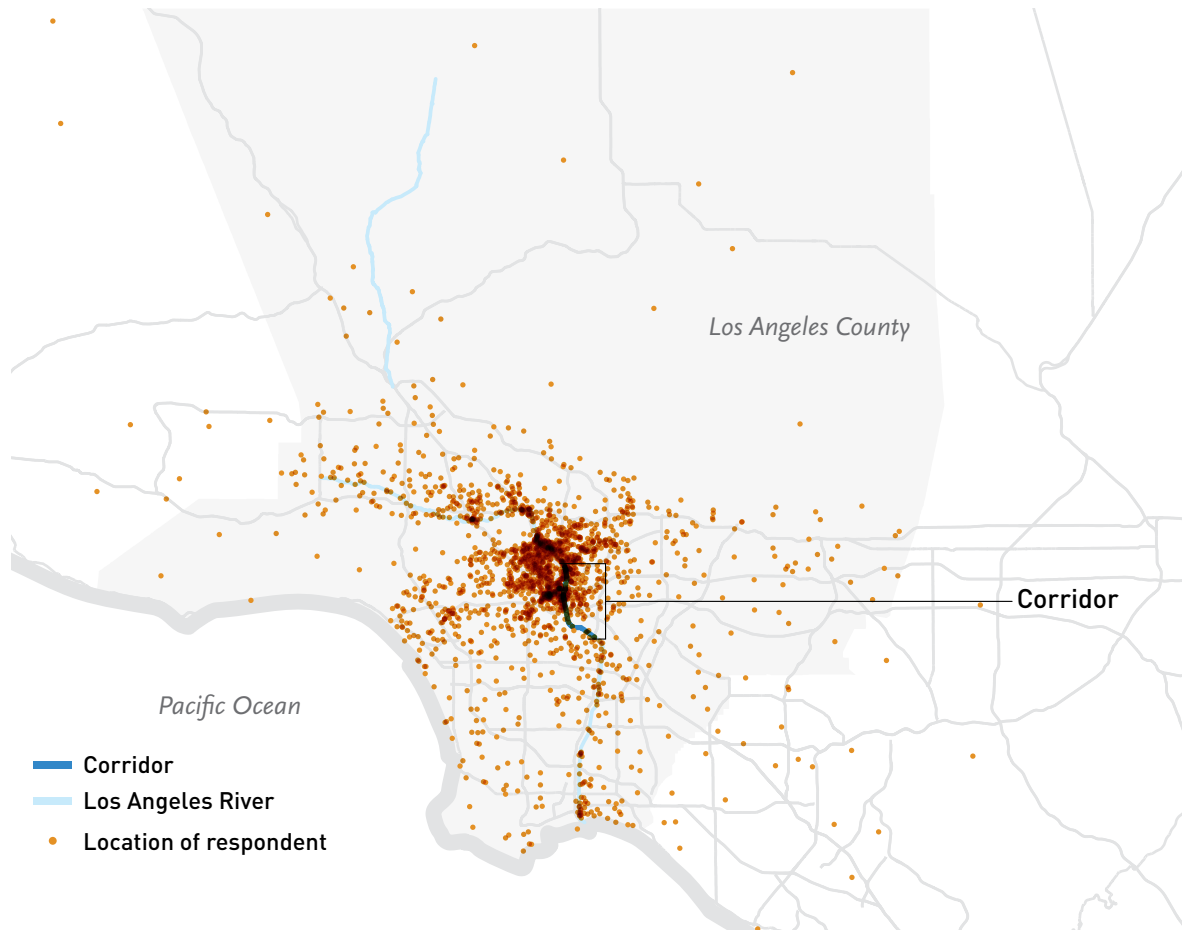
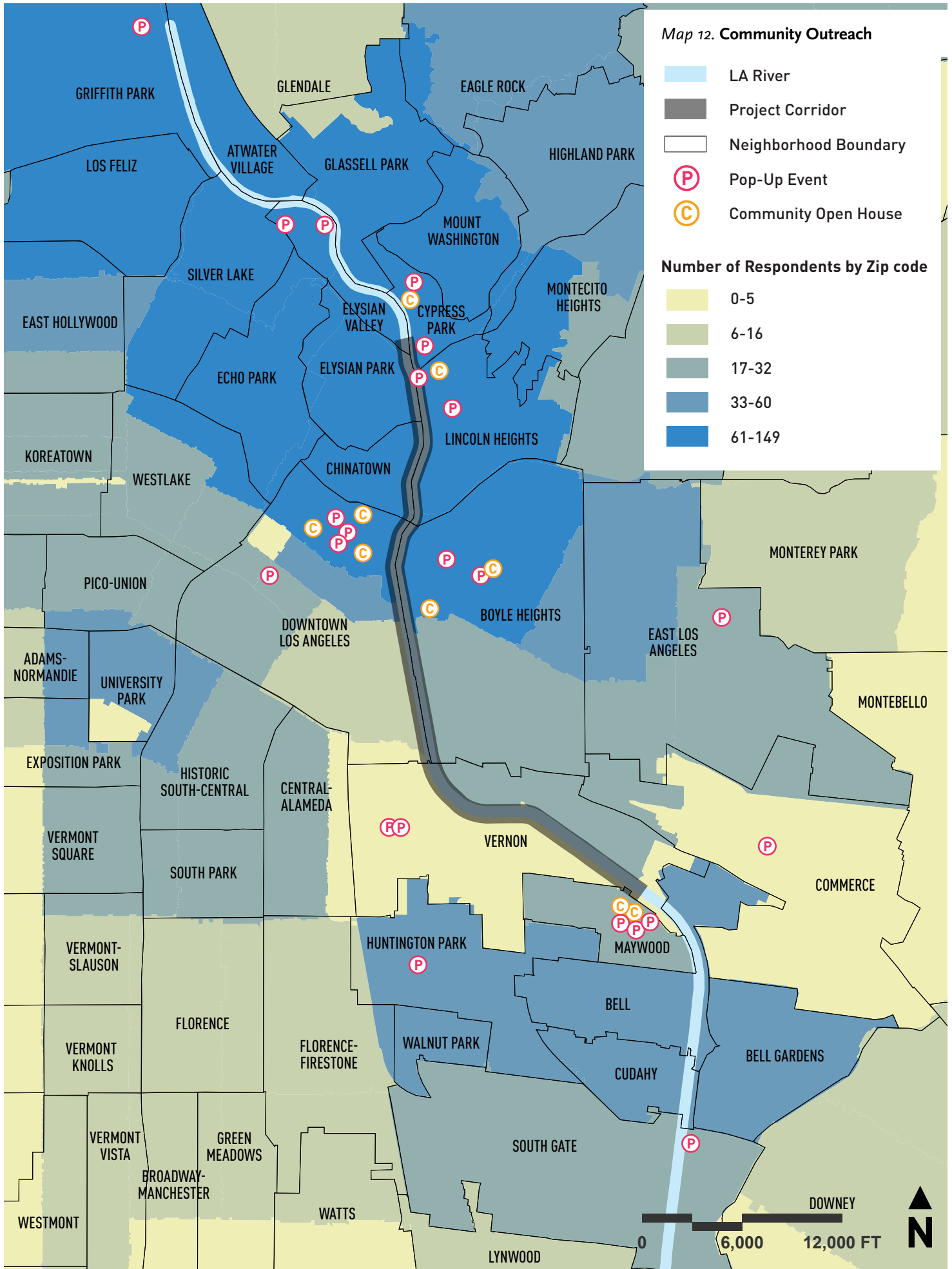

Figure 15. Self reported locations of people who participated in community engagement across the Los Angeles region.





Outreach Events

Path Mission, Vision, and Goals



August–November, 2018

-
- 3 Community Meetings
 - 2 Stakeholder Roundtables
 - 1 Coffee with the Principal Meeting
 - 1,915** Survey Responses
-

The first round of outreach events took place between August and November 2018, and was primarily focused on familiarizing the community with the LA River Path project and gathering community feedback on the project mission statement and six draft project goals: Safety, Access, Efficient and Sustainable Mobility, Equity, User Experience, and Health. During these events, community members were asked to comment on how they currently use the Los Angeles River, as well as their vision and goals for the future path.

Two stakeholder roundtables and three community open houses were held during this period. In addition, Metro also attended meetings with neighborhood councils, residential block groups, community-based organizations, business owners, and others. Online and in-person surveys



44. Community open house in Maywood

were also conducted at locations along the existing and future path and at nearby Metro Gold Line Stations.

When asked to describe their vision for the path and prioritize the issues most important to them, community members overwhelmingly provided comments relating to two goals: User Experience (58%), e.g., landscaping, shade, and maintenance, and Safety (28%), e.g., lighting and separation of users. Additional feedback on path mission and goals can be found on pages 39–44.

Outreach Events

Access Points and Path Types



January-February, 2019

- 3** Community Meetings
- 1** Stakeholder Roundtable
- 1** Coffee with the Principal Meeting
- 1,912** Survey Responses

The second round of outreach took place during January and February 2019. During this round, the project team held one stakeholder roundtable, three community open house meetings, and one Coffee with the Principal meeting, engaging with over 150 community members from neighborhoods throughout and near the assessment area. The project team also launched an interactive online survey tool to complement the in-person outreach meetings, receiving over 1,900 responses from community members from throughout Los Angeles County. The focus of the second round of outreach was to gather feedback on path opportunities such as potential path types and access points.



45. Community open house in Cypress Park

Although the results varied by meeting and online responses, overall, community members overwhelmingly supported the top-of-bank/cantilevered (40%) and elevated (32%) path types. Community members preferred these path types because of their potential to stay open year round, as well as their ability to provide space for amenities such as shade structures, lighting, and landscaping. Responses regarding preferred access points also varied by source, but consistently included access points such as LA State Historic Park/Main Street, Union Station, 1st Street, and Washington Boulevard.

The input received during this round directly impacted the alternative evaluation process, complementing the technical evaluation to develop potential alternatives for further study. See page 191 for a detailed summary of the community's feedback on path types and access points.

Outreach Events Path Alternatives



May, 2019

-
- 3 Community Meetings
 - 1 Stakeholder Roundtable
 - 1 Coffee with the Principal Meeting
-

After incorporating the community input received during the first two rounds of outreach, the project team developed path alternatives to share with the public during a third round. One stakeholder roundtable, three community open house meetings, and one Coffee with the Principal meeting were held in May 2019, giving community members an opportunity to review the proposed alternatives and provide comments. In addition, Metro also attended meetings with neighborhood councils, council districts, community-based organizations, and business organizations, among other stakeholders. Metro also produced a video summarizing the conceptual design phase and shared it via social media. Overall, most community members at the events were supportive of the recommended path alternatives,



46. Community open house in Cypress Park

noting that the alternatives captured the most important access points. Additional comments heard included the desire for a user separated path, the need for a reliable path that would stay open year round, and the importance of safe on-street connections. See page 233 for a summary of the community's feedback on path alternatives.

The LA River Path project will endeavor to incorporate the needs and desires of community members and stakeholders. Therefore, an extensive community outreach strategy will be ongoing throughout the life of the project in order to identify and address prevailing issues, needs, and desires. Robust community outreach will continue during the environmental phase and throughout the life of the project.

COMMUNITY FEEDBACK ON PATH MISSION AND GOALS

Early engagement activities between August and November 2018 were focused on familiarizing the community with the project and understanding community priorities for the future LA River Path. A number of outreach events and a survey tool were used to capture community comments, which were then organized by theme and translated into draft project goals. Community input also helped shape the draft mission statement for the project.

Vision for the LA River Path

Several consistent themes emerged from the early engagement events:

- **Create a great user experience**
- **Make the path safe**
- **Desire to use path for recreation and commuting**
- **Provide access to transit, jobs, and key destinations**

Community members at in-person outreach events were asked to describe “What’s Your Vision?” for the LA River Path.

User experience and safety were the two project goals that resonated most with community members, with 58% of input received relating to user experience (such as programming activities along the path, providing shade, seating areas, water fountains, restrooms, landscaping, and keeping the path well maintained) and 28% relating to safety (such as having a well-lit path through security lighting, providing a clear separation between people bicycling at high speeds and people walking, and making the path welcoming and safe for all users)(Figure 16). People from all communities expressed concerns that encampments along the path make the path feel less safe for path users.

Some variation among the goal priorities was seen between the three neighborhoods where the community open houses were held (Figure 17). Attendees at the Union Station event prioritized the efficient and sustainable mobility goal, followed by user experience and access. In Boyle Heights, the equity and health goals received the highest number of comments, followed by access. Participants at the Maywood event ranked the user experience goal as the highest priority, followed by access.

Figure 16. “What’s Your Vision?” overall results summarized by project goals

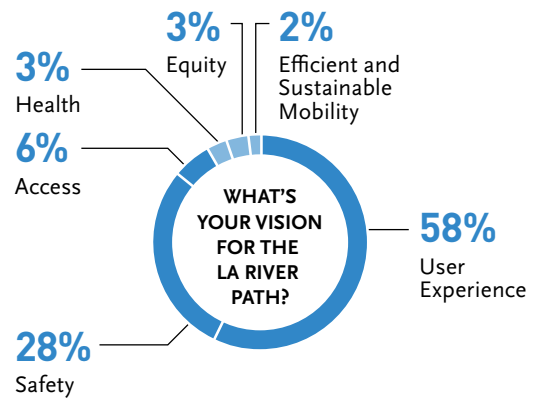
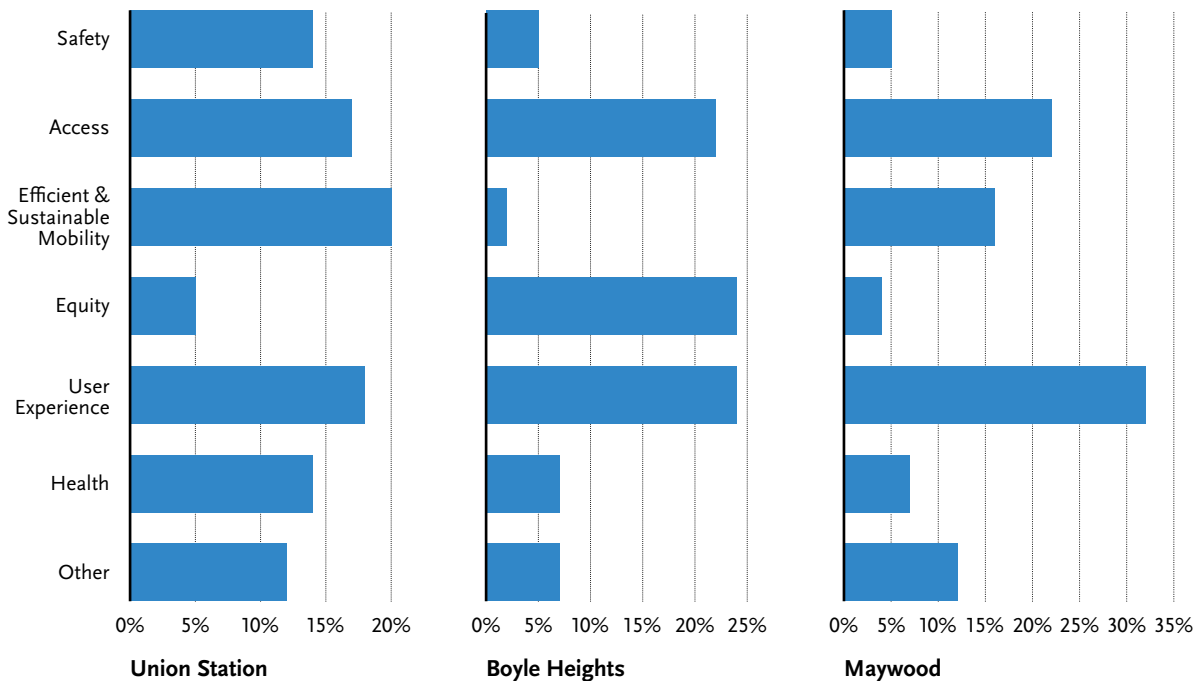

Figure 17. “What’s Your Vision?” results summarized by neighborhood





Current Use and Perceptions of the Los Angeles River

At the in-person outreach events, community members were also asked to describe how they currently use the Los Angeles River. Forty-one percent of people currently use the existing paths along the Los Angeles River for active recreational uses such as walking or bicycling, while only 3% use them for commuting purposes. Forty-two percent of community members stated they do not currently use the river either because it is difficult to access, concerns for safety, or because they do not know about it. Results are shown in Figure 18.

The LA River Path project aims to help alleviate these concerns. The path will help provide access to and along the river through its access points, improve safety from existing conditions, and bring attention to a local natural resource.

Across all neighborhoods, community members who participated in the pop-up outreach events said they mainly use the existing paths along the Los Angeles River for recreation and exercise. Residents who attended events in Elysian Valley, Vernon, and Huntington Park, which are the communities directly adjacent to the existing paths, reported the highest current use for recreation.

Ten percent of participants who attended events in Vernon and Huntington Park use the path for commuting purposes.

Figure 18. “How Do You Currently Use the River?” overall results

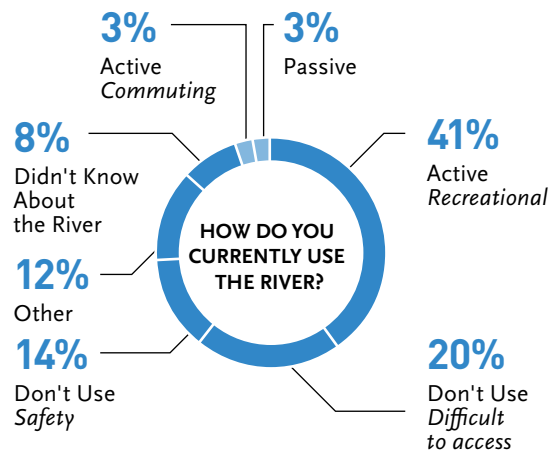

This is nearly five times the bicycling commuting mode split in the Los Angeles region (2.5%)¹ and five times that of the respondents from the other neighborhoods.

To better understand why people may not be using the existing paths, participants were asked what was preventing their use. In East Los Angeles, almost half of community members (48%) don't use the existing paths due to access issues, while only a quarter (25%) in Commerce and 17% in Vernon and Huntington Park cite access as the largest barrier. These results correlate with the distance of each community from the river, as the farther away people live from the river, the more difficult it is for them to access it. A lack of on-street bicycle connections to the river may be leading to access difficulties.

¹ 12017 American Community Survey 5-Year Estimate, Means of Transportation to Work

Figure 19. “How Do You Currently Use the River?” results summarized by neighborhood

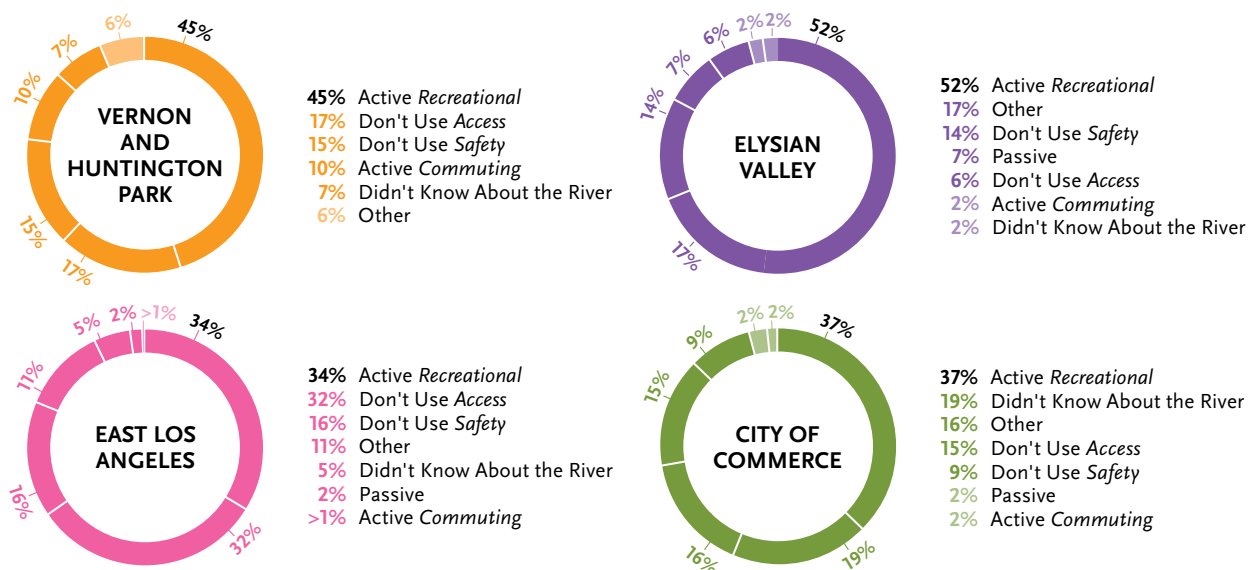

Knowledge of the existing paths is also a barrier to community members. Overall, 15% of respondents who don't use the paths reported they didn't know about it. In Commerce, nearly 33% of community members who reported they don't use the existing paths said they didn't know about it. Neighborhood results of the pop-up events are summarized in Figure 19.

Priorities for the LA River Path

Some of the priorities heard most frequently from community members were the need for a well-maintained path with amenities such as shade and lighting, as well as a desire for the path to be wide enough with separate lanes for bicyclists and pedestrians to limit user conflicts. Additionally, community members repeatedly reported a desire for the path to connect with existing bicycle and transit networks, key destinations in their neighborhoods, and the river's natural resources.



47. Community Meeting, Boyle Heights, CA



48. Community Outreach Meeting. Boyle Heights, CA.

During an activity at the community outreach meetings, the project team asked community members to spend “River Dollars,” tokens created for the purposes of the activity that allowed people to assign values to different elements, on statements that touch on some of the project goals. Community members were given six “River Dollars” and asked to spend them on the statements that resonated with them most. The four options participants could spend their “River Dollars” on were:

- **“A path that gets you where you want to go”**
- **“A path that is open everyday”**
- **“A path that has great views”**
- **“A path that is mostly flat”**

Participants from every community overwhelmingly prioritized “A path that gets you where you want to go,” which relates to the access goal. The access goal was the second and third ranked goal in the previously described exercise.

When combined, community members at the Boyle Heights and Union Station events considered “A path that is open every day” to be the second most important priority. However, community members from Maywood thought “A path with great views” highlights the importance of the user experience goal.

Future Use of the LA River Path

A survey, both on-line and intercept, was distributed between September and November 2018 to provide the community with an additional method with which to offer feedback on their desired use of the LA River Path. The survey was completed by approximately 1,900 community members. Results are summarized in Figure 20 and Figure 21.

Figure 20. Survey results from “How might you use the new LA River Path?”

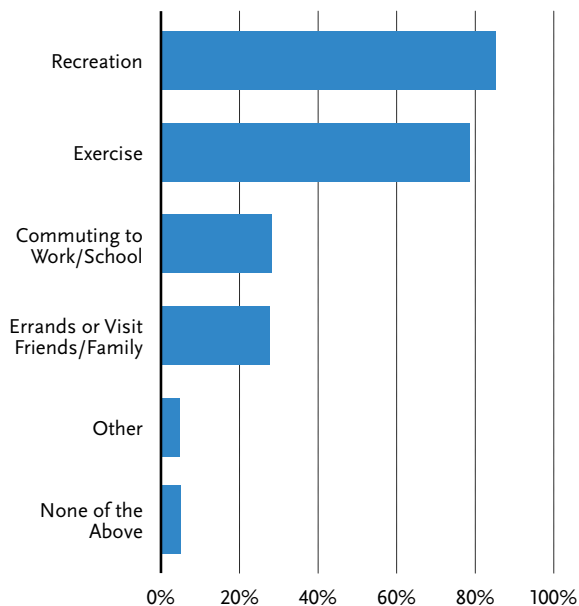
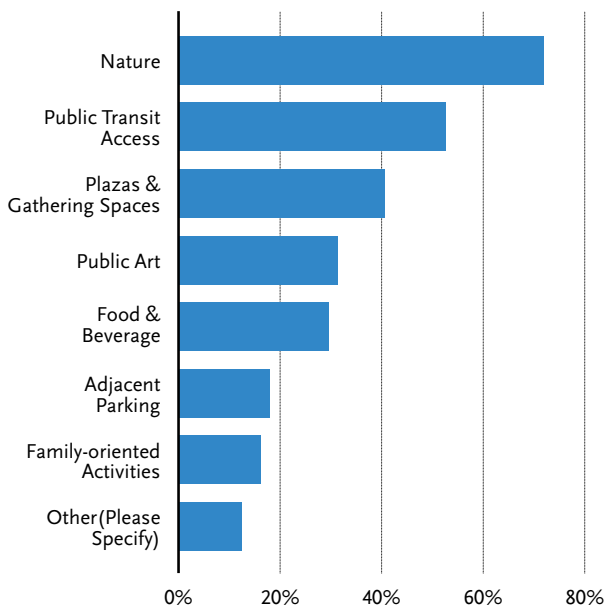

Figure 21. Survey results from “What would you like to see at the new LA River Path?”



There is a strong desire to use the path for recreation and exercise, and this result supports the project’s health goal. Although a less common response than recreation or exercise, nearly 30% of respondents would like to use the path for commuting to work or school as well as to run errands or visit family or friends. The percentages of these proposed utilitarian uses exceed existing utilitarian uses by nearly ten times.

In addition, the majority of survey respondents want to see nature at the new LA River Path. Although lined with concrete, the Los Angeles River is an important urban ecological corridor. The LA River Path has the potential to bring communities closer to the river’s natural resources.

Additionally, people ranked public transit access or gathering spaces as one of the top three elements to have along the future LA River Path.

Finally, the survey also asked people to share places they would like to get to from the new LA River Path. Downtown Los Angeles, the Arts District, Chinatown, Union Station, Boyle Heights, Long Beach, and the Los Angeles River itself were among the top responses.

Continued Outreach

Although these initial outreach activities concluded in fall 2018, community engagement continued throughout the full conceptual design phase of the project. In spring 2019, community engagement was focused on gathering input on specific design elements such as access point opportunities, path types, and draft path alternatives. This feedback is detailed in Chapters 9 and 10.



04

PATH ANALYTICS

Why is this important?

Path analytics is the practice of using data to inform path design. Understanding how people will use the path is an important aspect of quantifying projected future use.



How does it apply to the LA River Path?

A set of analytical tools were used to understand the unique characteristics of the Los Angeles River corridor and to predict how people will use the path.

Chapter 4 outlines the intended path users as well as the process to estimate the demand for the future LA River Path. Level of Service and Level of Comfort analyses and their role in understanding path widths are also discussed.

ANALYTICS INTRODUCTION

Using Data to Help Inform Path Design

The LA River Path will create an active transportation corridor for users of all ages and abilities. It will provide a new place for walking, running, bicycling, and other activities separated from vehicular traffic.

An origin and destination (OD) analysis provides a look at existing and future travel patterns of people walking and bicycling. Demand modeling estimates the volumes, travel modes, and likelihood that people will use the path. These demand projections can be used in Level of Service (LOS) and Level of Comfort (LOC) analyses to help inform how wide the future path should be to accommodate expected users. Figure 22 provides an overview of how these studies are used to inform the design process.

These studies will impact future design decisions about path width, slope, and the potential separation of users on the path.

The project team repeatedly heard from community members that the existing paths along the Los Angeles River are occasionally too narrow to comfortably accommodate the people that use them. The analyses detailed on pages 49–65 will help the project team design a path that is of appropriate width for expected user demand and provides a high level of comfort for path users of all ages and abilities.

Figure 22. Path Analytics Overview Flow Chart
How can we use data to help inform the path design?

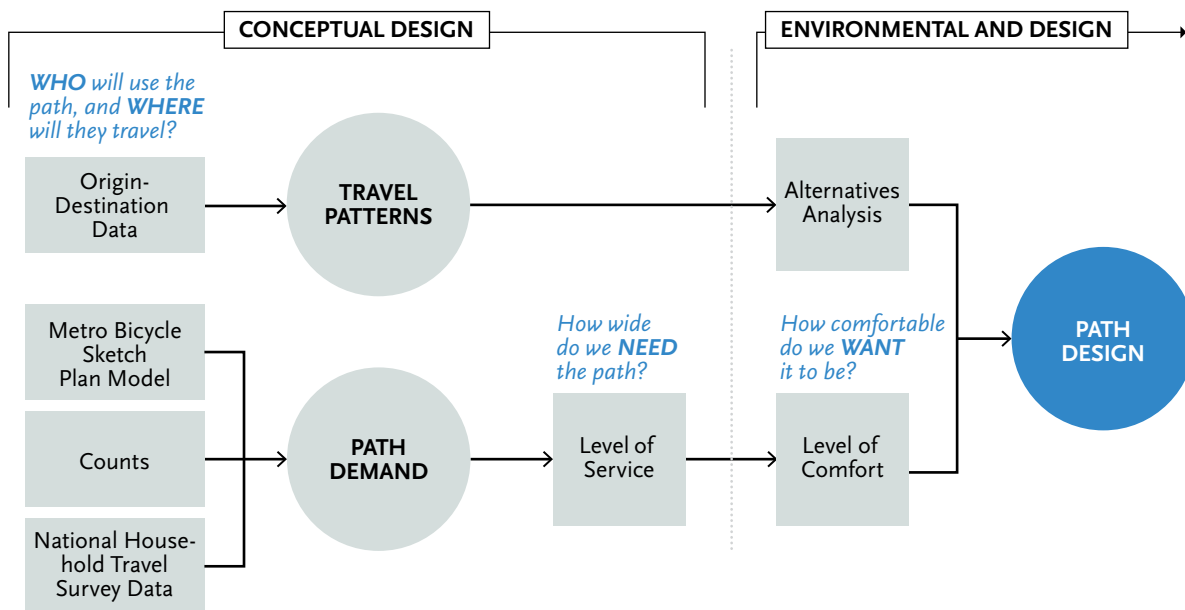

ORIGIN AND DESTINATION ANALYSIS

OD Analysis Method

In order to better understand current and estimated future activity near the project corridor, the project team conducted an OD analysis of existing travel patterns in the area.

Using data from the Metro Corridors Based Model 18 (CBM18), the project team determined the trips that could reasonably be made by bicycle and foot, and used them to identify the locations in the assessment area with the greatest levels of potential bicycling and walking activity, and areas with high potential for trips crossing the river.

The OD travel patterns were then compared to predicted activity patterns for the year 2042 (the projected year from the Metro CBM18) to identify changes in potential activity levels over time.

OD Conclusions

The results from the OD analysis allow the project team to better understand potential current and future bicycle and pedestrian travel patterns in the assessment area.

Maps illustrating the results of the OD analysis follow in Maps 13–15. They depict travel patterns in 2017 (Map 13), predicted travel patterns in 2042 (Map 14), and the change in those travel patterns between the two time periods (Map 15). This comparison allows the project team to identify not only areas of current and future travel intensity, but also to identify likely geographical shifts in travel patterns over the next 25 years.¹

¹ Metro. 2019. *LA River Path Project Origin and Destination + Demand Analyses*. Los Angeles, CA.

Map 13. Potential Bicycling and Walking Trips within the Assessment Area in 2017

- 174 to 559 Trips
- 60 to 173 Trips
- 24 to 59 Trips
- 8 to 23 Trips

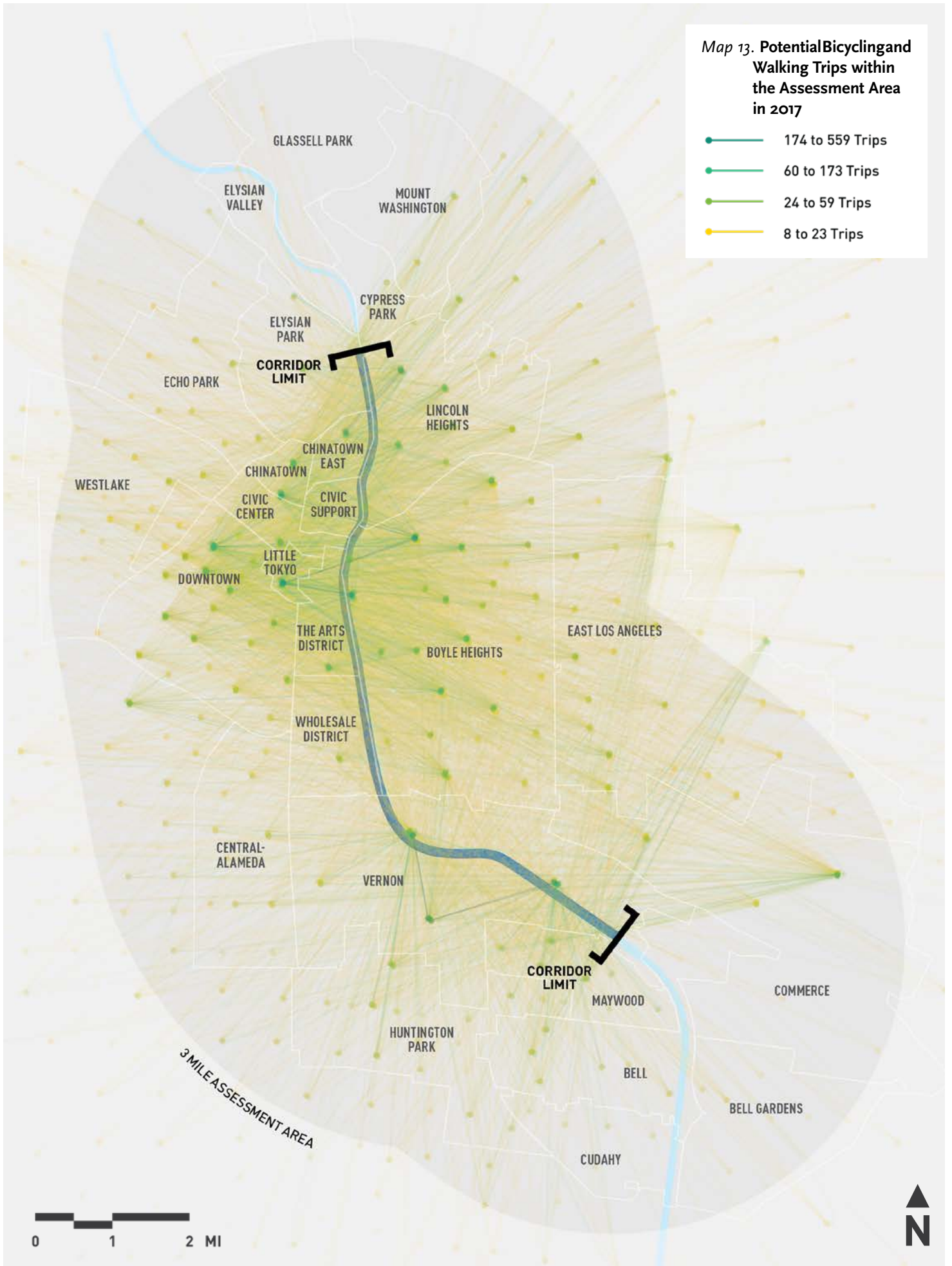

Map 14. Potential Bicycling and Walking Trips within the Assessment Area in 2042

- 174 to 559 Trips
- 60 to 173 Trips
- 24 to 59 Trips
- 8 to 23 Trips

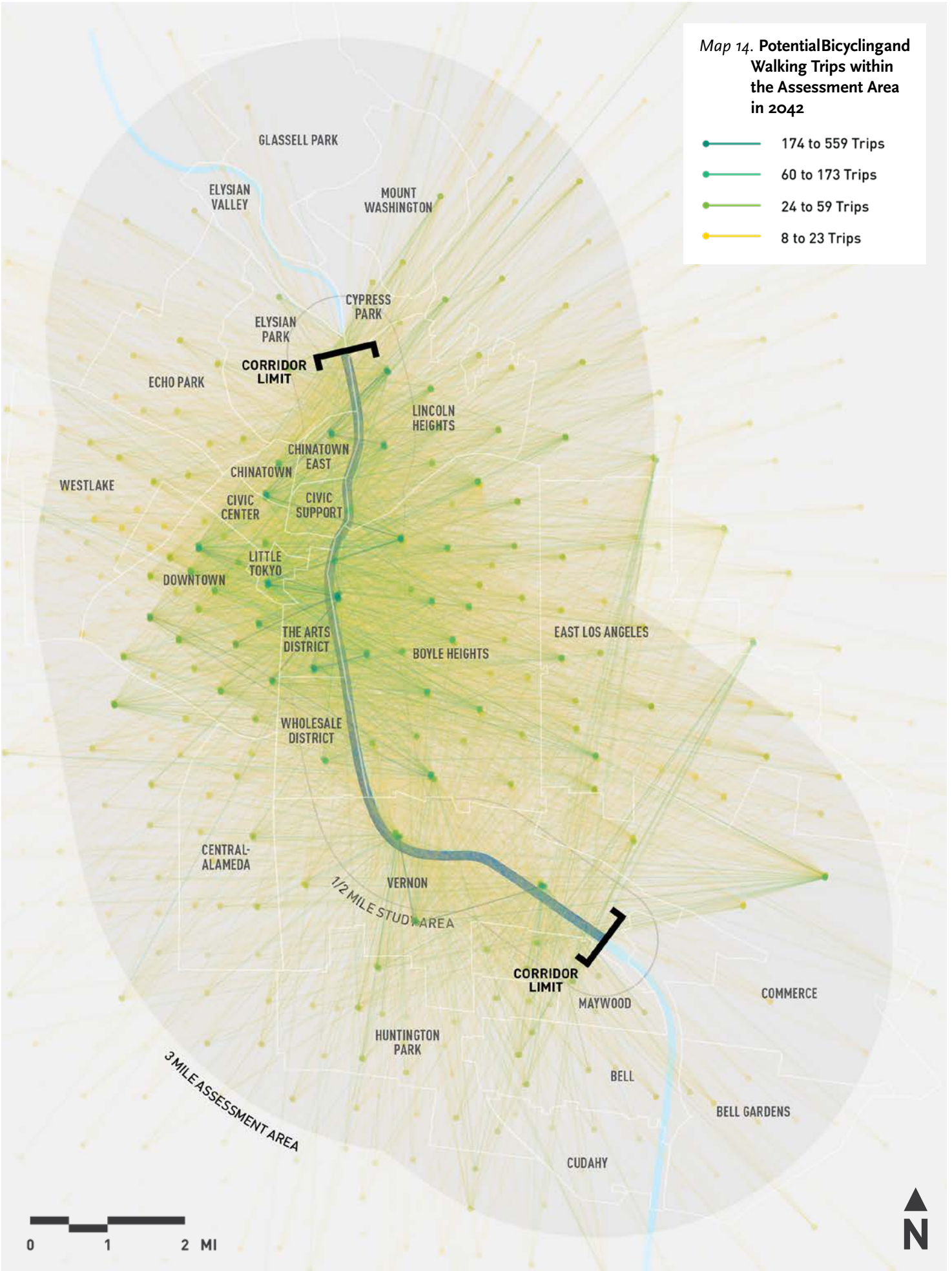

Map 15. Potential Increase in Bicycling and Walking Trips in the Assessment Area Between 2017 and 2042

- 97 to 231 Trips
- 30 to 96 Trips
- 11 to 29 Trips
- 2 to 10 Trips

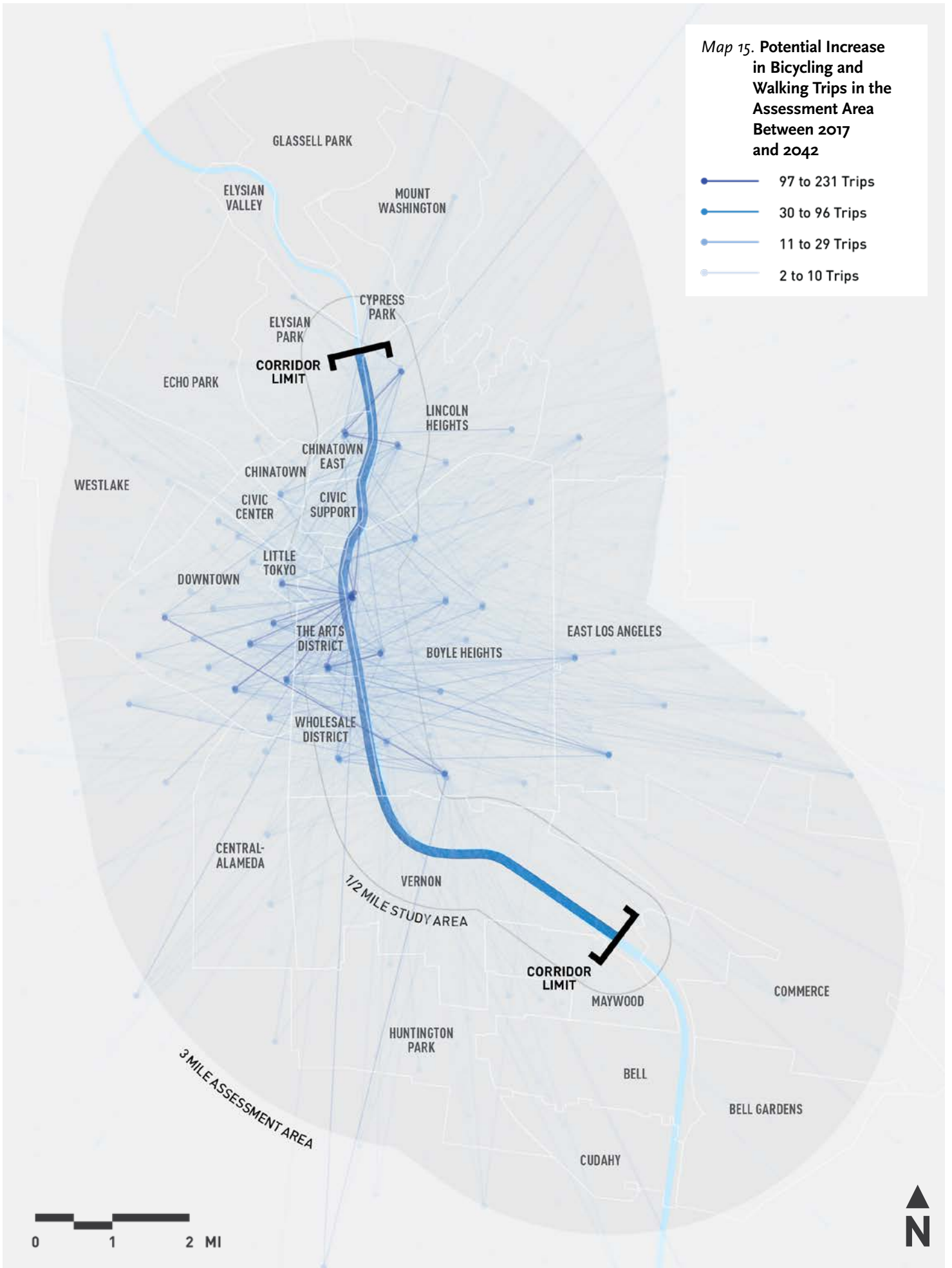

PATH DEMAND ANALYSIS

Path Demand Analysis Methods

The demand analysis for the LA River Path provides a relative activity assessment for the path along eight segments. The segments were identified by determining where the logical breaks were along the corridor based on existing conditions. Distinct from the OD analysis, the demand analysis used data sources and analysis methods to estimate user volumes and travel modes along the future path itself, rather than overall travel patterns.

The analysis integrated peak hour and long-term counts, and calculated a baseline bicycle utilitarian activity estimate for the year 2035, based on the 2014 LA Metro Bicycle Sketch Plan Model (BSPM). The BSPM was used for the demand analysis instead of the CBM18 because of its ability to provide more specific data related to bicycling activity, despite the fact that it projects out the 2035 instead of 2042. Multiple linear regression was used to develop a formula to account for changes along the study corridor and

adjust the baseline bicycle activity up or down by adjusting it for localized conditions, and determining a margin of error. Data inputs included both historic (2012–2017) and current (2018) user counts, demographic data, and bicycle infrastructure. Guidance from the *FHWA Shared-Use Path Level of Service Calculator* (SUPLOS) was used to develop estimated utilitarian pedestrian trips.

National Household Travel Survey (NHTS) 2017 data was used to determine recreational bicycle and pedestrian trip estimates for each segment of the path.

Path Demand Conclusions

It is anticipated that in 2035 the LA River Path will serve up to 5,900 daily bicycle and pedestrian trips, varying throughout each of the corridor's eight segments. In the lower demand areas, only about 1,700 daily pedestrian and bicycle trips are expected.¹ Anticipated daily bicycle and pedestrian trips results for all eight segments are shown in Map 16. The busiest areas of the path are expected to be in proximity to downtown Los Angeles, followed by the northern section, near Elysian Park. Activity is expected to decrease as the path moves south through Vernon.

The project team believes the results of the demand analysis provide conservative estimates. Although any demand analysis is subject to data constraints and limitations like the accuracy of underlying models and available count data, the estimated level of demand is consistent with similar existing urban multi-modal paths, including the Eastbank Esplanade in Portland, OR (approx. 3,000-4,000 daily trips) and the Hudson River Greenway in New York, NY (approx. 5,000-7,500 daily trips). Given the future path's location near downtown Los Angeles' dense urban core, it is expected that the estimated demand levels would be in line with or exceed these existing urban path examples.

Special Events

The turnout of bicyclists at special events indicates that there are far more bicycles in Los Angeles than there are daily bicyclists. While a statistical model cannot and should not incorporate special events into average daily ridership, these events do indicate that the path may see far higher levels of use. Large events may attract even higher numbers of riders on the path than predicted through the regression model. One example are the popular CicLAvia open streets events. These events have been attended by over 1.6 million people over 29 CicLAvia events during the past nine years. On average, 55,000 people attend each one-day event.¹ This indicates that significant numbers of people are interested in bicycling, walking, and rolling in safe and comfortable environments.

¹ <https://www.ciclaviva.org/about>

¹ Metro. 2019. *LA River Path Project Origin and Destination + Demand Analyses Report*. Los Angeles, CA.

This page intentionally left blank

Map 16. Anticipated Daily Bicycling and Walking Trips, 2035

LA River



LEVEL OF SERVICE AND LEVEL OF COMFORT ANALYSIS

Introduction

To provide a high quality experience that is safe, efficient, and comfortable for future path users, the project team performed a Level of Service (LOS) and a preliminary Level of Comfort (LOC) analysis to support the conceptual design phase by providing suggested path widths and facility types for consideration.

LOS is a tool that focuses on the capacity of physical infrastructure, while LOC provides a more comprehensive evaluation of physical infrastructure in conjunction with a facility's context and user experience. The LOC model incorporates the LOS factor as a weighted score, but includes additional factors to evaluate path user comfort including solar index, slopes, vehicle stress, context & views, and perceived crime risk. These factors will be updated in later phases of the study as the project design advances.

The project team completed a preliminary LOC analysis during the conceptual design phase, and will conduct a final analysis during the environmental clearance and design phase to help make design decisions once the project has progressed further into design and engineering.¹

LOS Analysis

The purpose of calculating LOS for the LA River Path project is to ensure that the project provides appropriately sized facilities that will accommodate existing and projected user demand (see Map 16 on page 56). The analysis uses the Federal Highway Administration (FHWA) Shared-Use Path Level of Service (SUPLOS) Calculator to determine LOS scores, and is based on the following assumptions:

- User demand and mode are based on the LA River Path's demand analysis, which incorporates existing activity data and user surveys, and provides projections of potential future path use.
- The models will help to define an optimal shared-use path width, as well as minimum path widths to be employed when constrained conditions are encountered.
- In some circumstances, user-separated facilities (separate, dedicated path space for people walking and for people bicycling) will be considered, which dramatically improves the FHWA LOS score.

¹ Metro. 2019. *LA River Path Project Level of Service and Level of Comfort Report*. Los Angeles, CA.

Interpreting LOS Grades¹

- A Excellent.** Path has optimum conditions for people bicycling and retains ample space to absorb more users of all modes, while providing a high-quality user experience.

- B Good.** Path has good bicycling conditions and retains significant room to absorb more users, while maintaining a high-quality user experience.

- C Fair.** Path has at least minimum width to meet current demand and to provide basic service to people bicycling. A modest level of additional capacity is available; however more people walking or running, or other slow-moving users, will begin to diminish LOS for people bicycling.

- D Poor.** Path is nearing its functional capacity given its width, volume, and mode split.

- E Very Poor.** Given path width, volume, and user mix, the path has reached its functional capacity.

- F Failing.** Path significantly diminishes the experience for at least one, and most likely all, user groups.

¹ FHWA Shared-Use Path Level of Service Calculator; A User's Guide <https://www.fhwa.dot.gov/publications/research/safety/pedbike/05138/chapter3.cfm>

LOS ANALYSIS RESULTS

The project team used the FHWA SUPLOS Calculator and estimated user volumes from the path demand analysis to determine LOS scores for each segment of the path.

Based on stated user volume assumptions, LOS scores were calculated for a range of path widths in order to identify meaningful differences in scores based on user demand by segment for shared-use and separated facilities.

SHARED-USE FACILITY SCORES

For shared-use facilities in low demand areas (88-135 users per hour), a 14-16-foot minimum width is preferred to achieve LOS Level B, a score that is considered to be high performing by FHWA standards. For high demand areas (176-254 users per hour), a user separated facility is preferred to achieve LOS Level B. In segment 5, the segment with the highest expected demand, a separated facility is required in order to achieve LOS Level B. This analysis was used to determine preliminary path width considerations based on LOS scores that are considered acceptable by FHWA standards. The project team may define other acceptable ranges for LOS scores, minimum path widths, and facility types during the next phase of the project.

SEPARATED FACILITY SCORES

LOS calculations were also completed for a separated use facility by retaining the default FHWA mode split proportions for fast user groups (i.e. adult and child bicyclists and in-line skaters) but removing the pedestrian contribution. Rolling path widths of 8-14 feet and walking path widths of 6-8 feet were used for the analysis, for a combined width of 16-20 feet.

Separated facilities are typically preferred in high demand areas in order to achieve high LOS scores. In low demand areas, shared-use facilities are sufficient to achieve acceptable scores.

For user separated facilities in high demand areas, a 12-foot minimum width facility should be provided for people riding bicycles or rolling, with a separate 6-8-foot path for pedestrians. This combined 18-20-foot total width provides a higher LOS within a smaller footprint compared to a shared-use facility.

User Demand Assumptions for the LOS Analysis

User demand assumptions, described in terms of one-way users per hour at peak travel times, were derived from the LA River Path Demand Analysis (2019). Estimated daily trips were converted to one-way users per hour using National Bicycle and Pedestrian Documentation Project (NBPD) factors and based on a typical weekday peak hour of 9:00am - 10:00am. The results provide the number of one-way users per hour during peak weekday commute times. The lowest volumes are expected in Vernon between Atlantic Boulevard and Soto Street and the highest volumes are expected between E 7th Street and the Piggyback Yard area.¹

¹ Metro. 2019. *LA River Path Project Origin and Destination + Demand Analyses Report*. Los Angeles, CA.

Path Width Considerations Based on LOS Results

Projected user demand, separation of users and modes, and the physical characteristics of the corridor all play a role in determining LA River Path widths and configurations. The LOS analysis results show potential path widths for both shared-use and separated use configurations for expected user demand.

Path width considerations exist for each of the eight segments. For illustrative purposes, considerations are shown by three project reaches—north, central, and south—that were determined by grouping

the segments together based on existing conditions and expected demand.

Figure 23 shows an example of the existing path width for the Los Angeles River Bicycle Path south of the project corridor. This 14-foot shared-use path is being considered for low-demand areas of the path.

Figure 24-Figure 27 show potential path widths and configurations based on the results of the LOS analysis. The results are shown by project reach.

Figure 23. Existing Shared-Use Path in Bell

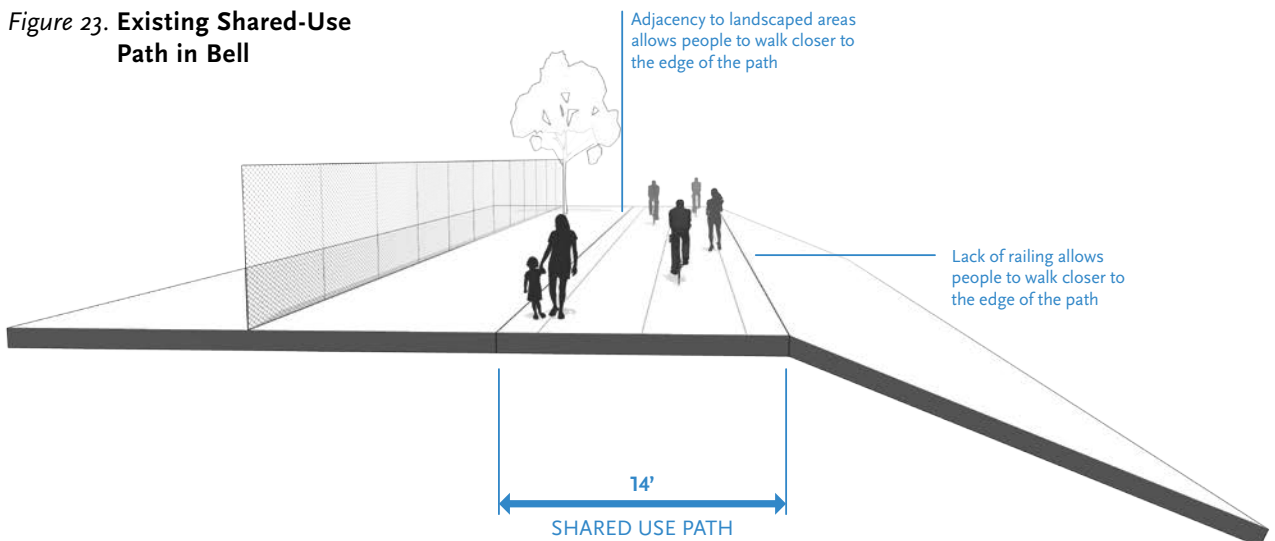

North Reach

The North Reach features two levels of demand. In the northernmost segment (the northern terminus of the project to south of the Gold Line), demand is expected to reach up to 135 one-way users per hour in 2035. In this section, the project team is considering a 16-foot shared-use path to meet demand as shown in Figure 24.

Demand increases to medium-high through Lincoln Heights and Chinatown East. Demand is estimated to reach up to 216 one-way users per hour in 2035, over 5 times greater than the current use levels in Elysian Valley. For this level of demand, a separated use path will be evaluated in order to minimize conflict between people walking and riding bicycles as shown in Figure 25.

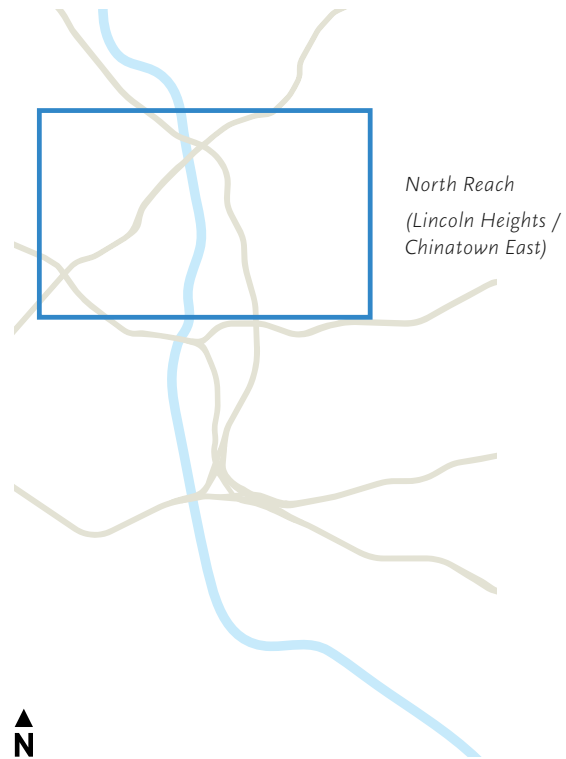

Figure 24. 16' Shared-Use—
Preliminary Consideration

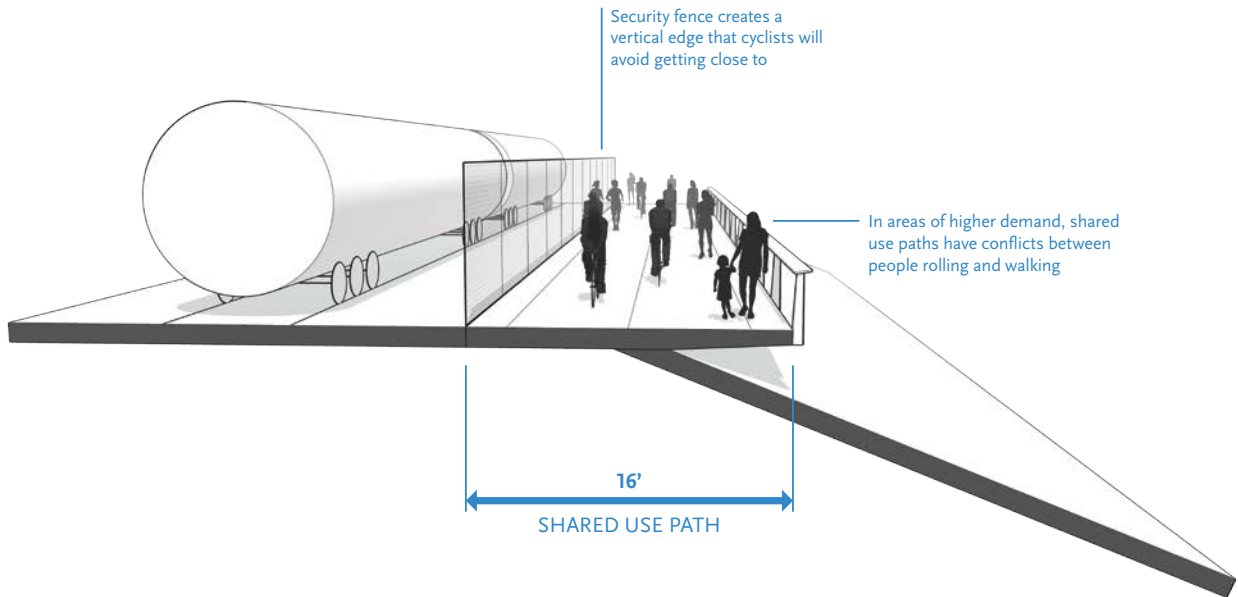
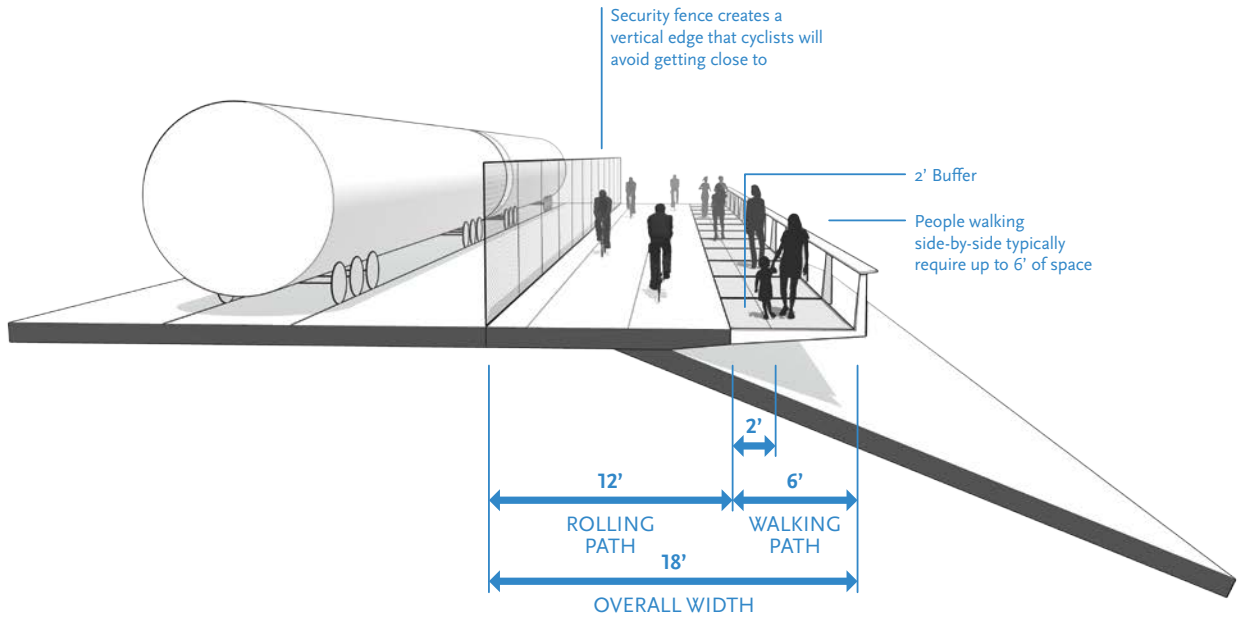

Figure 25. 18' Separated Use—
Preliminary Consideration



Central Reach

The Central Reach features high demand through Civic Center, Boyle Heights, and the Arts District. Demand is estimated to reach up to 254 one-way users per hour in 2035.

For this level of demand, a separated use path will be evaluated to minimize conflict between people walking and riding bicycles and achieve a LOS score of B or higher (see Figure 26).

For reference, in the Los Angeles County region, the Santa Monica Beach Path is a high demand path with a separated 20-foot-wide bicycle path and 14-foot-wide pedestrian path.

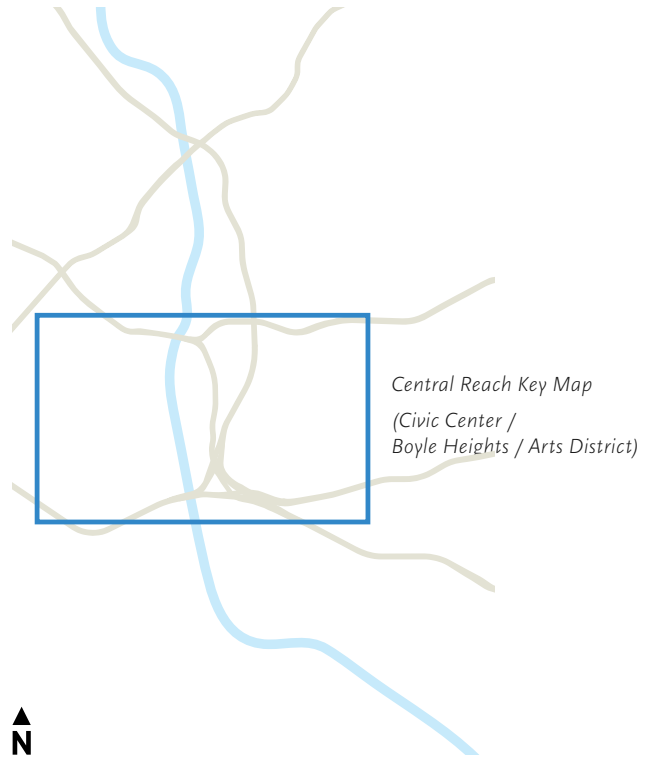
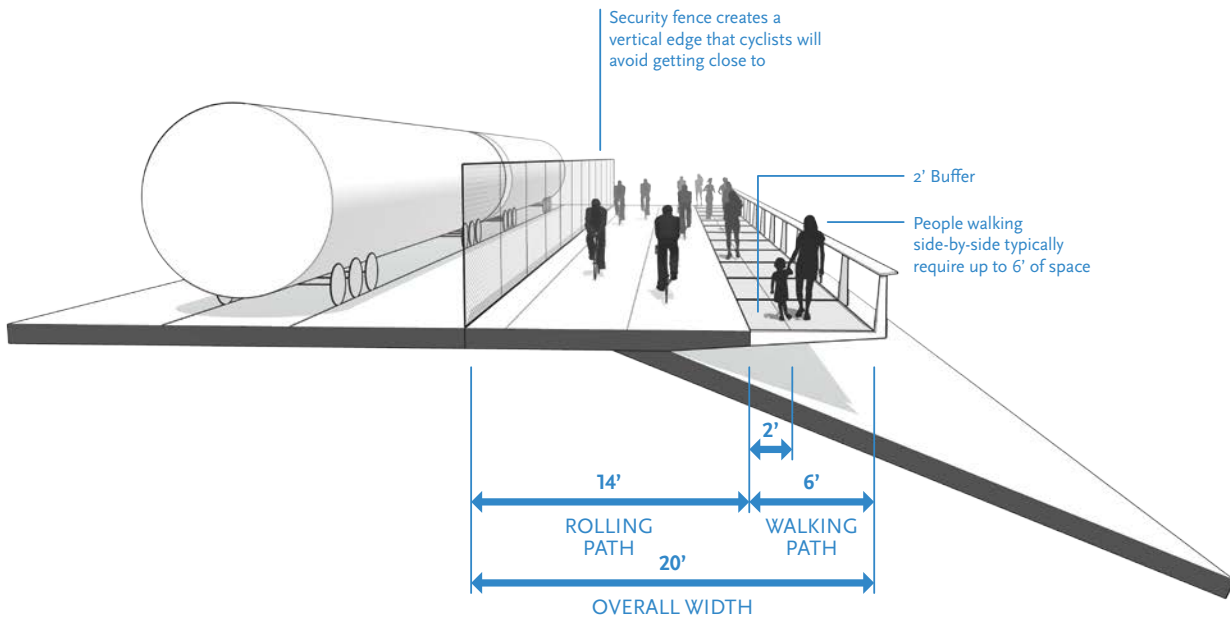

Figure 26. 20' Separated Use— Preliminary Consideration



South Reach

The South Reach features medium demand through Vernon. Demand is estimated to reach up to 128 one-way users per hour in 2035, over 3 times greater than the current use levels in Maywood/Bell.

For this level of demand, a 16-foot-wide shared-use path would be able to provide a comfortable user experience (see Figure 27).

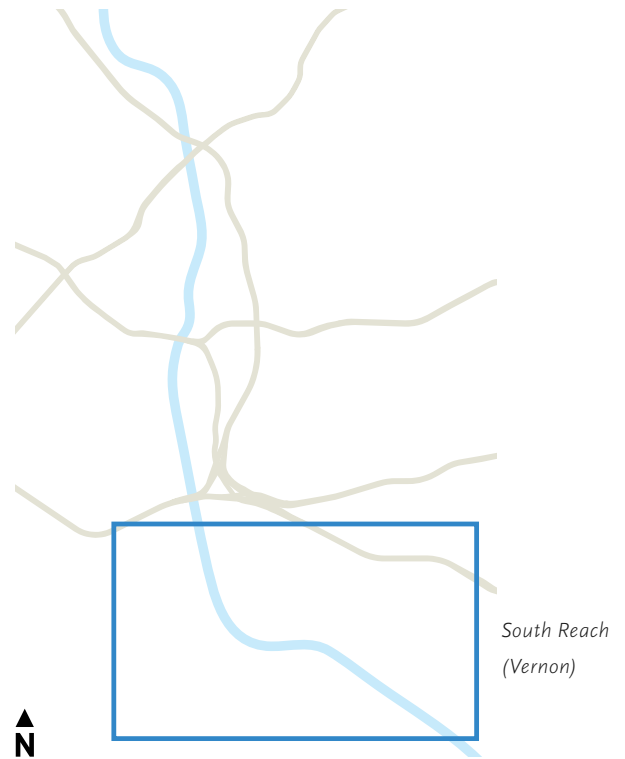
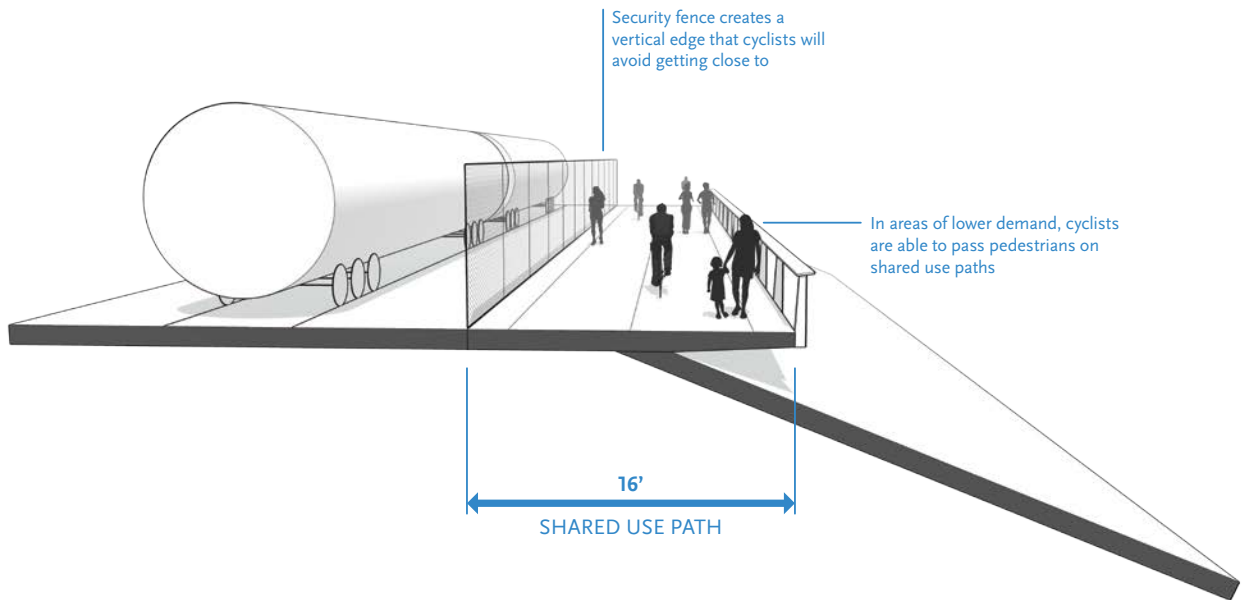

Figure 27. 16' Shared-Use—
Preliminary Consideration



LOC Analysis

The LOS results described in pages 57–64 outline preliminary path width and facility type considerations for the LA River Path. Alta’s LOC analysis uses these results as an input, but also addresses factors that are absent from the FHWA LOS model that nevertheless impact the success, safety, and enjoyment of multi-modal paths.

Particularly where a path system is intended to serve users of all ages and abilities, the transportation-oriented FHWA LOS model is limited. Alta’s LOC model incorporates the LOS score as a weighted factor but adds other relevant factors, including:

- **Solar Index:** The degree to which the path provides shade for path users.
- **Slopes:** The degree to which the path grades change, from Very Good (1-2%) to Unacceptable (>8%)
- **Vehicle Stress:** The degree to which the path is separated from vehicular traffic.
- **Context & Views:** The degree to which the path is buffered from unpleasant noise or odor pollution, and provides interesting vistas for path users.
- **Perceived Crime Risk:** The degree to which the path is visible from multiple angles and path users would feel seen on the path.

These factors are each given a score reflective of corridor conditions, ranging from 0-5, as well as a weighted score that reflects community and stakeholder priorities.

Understanding the LOC Scoring Matrix

LOC scores indicate anticipated path performance:

0	Unacceptable	3	Average
1	Very poor	4	Good
2	Poor	5	Very Good

Each factor follows the above grading scale, with the exception of Slopes, which uses specific standards per score:

0	Unacceptable	3	3-4%
1	5-8%	4	2-3%
2	4-5%	5	1-2%

Different path segments and scenarios can be tested in order to understand how different elements can impact user comfort on the path.

As a preliminary analysis, the project team chose two segments to serve as illustrative examples of how adjusting the scores of different factors can affect user comfort. Path widths and LOS scores described previously were used for the analysis. The results show that when all other factors remain the same, adjusting the scores of just two factors (for example, changing perceived crime risk and slopes from very good to very poor) impacts LOC scores significantly. This indicates that even when existing conditions require the path to be more narrow than needed to achieve optimal LOS, incorporating additional factors can still help the path feel safe and comfortable for path users.

The project team will conduct a final LOC analysis during the environmental phase to help determine design considerations for the path and evaluate the three path alternatives.

This page intentionally left blank



05

EXISTING CONDITIONS

Why is this important?

The eight-mile project corridor follows the flow of the river, and is surrounded by rail, roads, utilities, bridges, and pathways. All of those elements will influence the path design and how it is used and experienced.



How does it apply to the LA River Path?

The Los Angeles River is a complex and unique corridor, where urban and industrial uses, natural spaces, historic treasures, and cultural icons coexist and require different approaches to planning and design.

Chapter 5 provides a pre-environmental analysis of the corridor's existing conditions and surrounding land context, used to develop feasible alignment options, access points, and potential path alternatives for the LA River Path. It also highlights case studies of existing path O+M practices.

MOBILITY CONNECTIONS

Existing Paths Along the Los Angeles River

There are 24 miles of existing path along the Los Angeles River; however, the path is not continuous. The largest continuous gap is this project's corridor.

North of the gap, the Los Angeles River Greenway Trail runs seven miles from Griffith Park through Elysian Valley. The path is predominately at-grade, meaning it is located along the top-of-bank adjacent to the channel wall. The activity of this section is driven in large part by access to elements along the path such as parks and cafés, as well as access to the river itself. Small parks, trees, and community gathering spots line the path, providing shade, respite, and opportunities for communal activity for path users. Cafés have entrances that face the path and exemplify the path-oriented development that has taken place since the path's construction. This section is also part of the 2.5-mile Elysian Valley River Recreation Zone, an area where the public is allowed to access and enjoy the river in designated areas to walk, fish, and kayak. The popularity of the existing path has led to overcrowding and the narrow width of the path has been identified by the community as a concern.

At the southern end of the project corridor, the Los Angeles River Bicycle Path begins in Vernon and continues 17 miles to the Pacific

Ocean in Long Beach. In comparison to the northern section of the path in the Elysian Valley, this section is more open and visually homogeneous because of the consistently wide trapezoidal shape of the channel. The path is predominately at-grade and uses fences to provide a barrier to adjacent streets or lots, but along the river there is often no more than a short curb adjacent to the channel, which is illegal to enter at any time. This section provides an efficient path for through travel but lacks some of the elements of the northern segment, with little shade and few parks and gathering places.









Along the 17-mile Los Angeles River Bicycle Path, there are approximately 10 parks. Access to these parks from the path is somewhat limited due to a lack of access points and the high embankment on which much of the path sits. Many access points include stairs or dirt paths which are problematic for wheeled users and may not provide ADA routes. Seating along the path is limited and rarely shaded. Additionally, the path has limited lighting infrastructure, with only two light poles along the 17-mile stretch, and long stretches without shade, especially between Vernon and Maywood.

Map 17. Existing and Planned Bicycle Networks

-  LA River
-  Corridor
-  Existing LA River Path
-  Metro Rail Line Stops

EXISTING & PLANNED BICYCLE NETWORKS

City of LA Mobility Plan 2035
Vernon Bicycle Master Plan (2017)

-  Class I: Path
-  Planned
-  Class II: Bicycle Lane
-  Planned
-  Class III: Bicycle Route
-  Planned
-  Class IV: Separated Bikeway
-  Planned



Bicycle Network

The LA River Path will connect to on-street bicycle networks via access points. The LA River Path will be a Class I path and provide a low stress experience for people bicycling separated from vehicular traffic.* A low stress experience connecting to and from the LA River Path could be provided on other Class I paths, Class III neighborhood bicycle routes (i.e. shared-use, low volume, low-speed neighborhood streets), and Class IV separated bikeways. Map 17 shows existing and planned bicycle networks from the City of Los Angeles' Mobility Plan 2035 (an element of the General Plan) and Vernon's Bicycle Master Plan.

Pedestrian and Transit Networks

In addition to becoming a spine on the bicycle network, the LA River Path will also provide connections that serve people walking and taking transit.



The City of Los Angeles Mobility Plan 2035 identifies Pedestrian Enhanced Districts and a Transit Enhanced Network. These

networks are planned for street improvements that will increase access to area amenities through continuous, predictable and safe sidewalks, intersections, and transit support facilities. Access points along the river may connect to these districts and networks.

The LA River Path will also connect to Los Angeles Union Station, the region's largest transportation hub, providing an opportunity for users to connect with Metrolink, Amtrak, and Metro's countywide rail and bus lines. Finally, the West Santa Ana Branch Transit Corridor is a planned 20-mile light rail transit line that would run parallel to the LA River Path and connect downtown Los Angeles to southeast Los Angeles County expanding transit connections from Union Station (see Map 18).



*Class I bikeways are bicycle paths that are completely separated from roadways and can be shared with pedestrians, sometimes referred to as multi-use or shared-use paths.

Map 18. Mobility Connections



-  LA River
-  Corridor
-  Existing LA River Path

PLANNED MOBILITY NETWORKS

City of LA Mobility Plan 2035

-  Pedestrian Enhanced Districts
-  Transit Enhanced Network

EXISTING TRANSIT ROUTES

-  Metro Rail Line Stops
-  Metrolink Tracks

PLANNED TRANSIT ROUTES

-  Metro West Santa Ana Branch Transit Corridor Project



CORRIDOR CONDITIONS

Introduction

A pre-environmental analysis of existing corridor conditions was completed in order to provide context for conceptual design work and guide the development of feasible alignments, access points, and potential alternatives. Assessments of channel configurations, hydrology, railways, utility corridors, historic resources, bridges, right-of-way, hazardous materials, geotechnical resources, and ecological conditions are described in the following pages.

The River Channel

The width and shape of the Los Angeles River channel have a direct impact on where the LA River Path can be constructed. The Los Angeles River channel is broadly configured into two channel shapes, trapezoidal and rectangular, with a channel width ranging from approximately 200 to 500 feet. The trapezoidal channel is wider and features sloped walls, while the rectangular channel is more narrow with vertical walls. Transitional channels have both vertical walls and sloped walls, and are typically located between rectangular and trapezoidal channels. In general, narrower channels are easier for channel crossings while trapezoid channels can accommodate the greatest variety of path types. (See Figure 29-Figure 32).

51. Rectangular channel

52. Medium Trapezoid channel

53. Large Trapezoid channel

Figure 28.

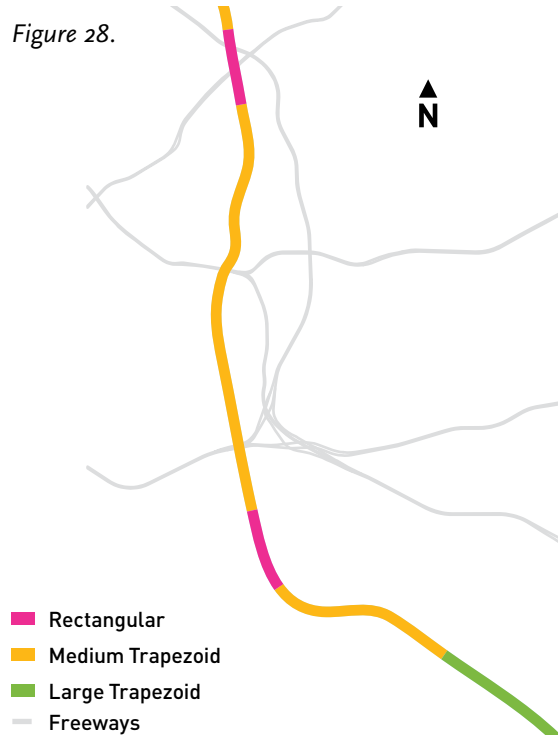

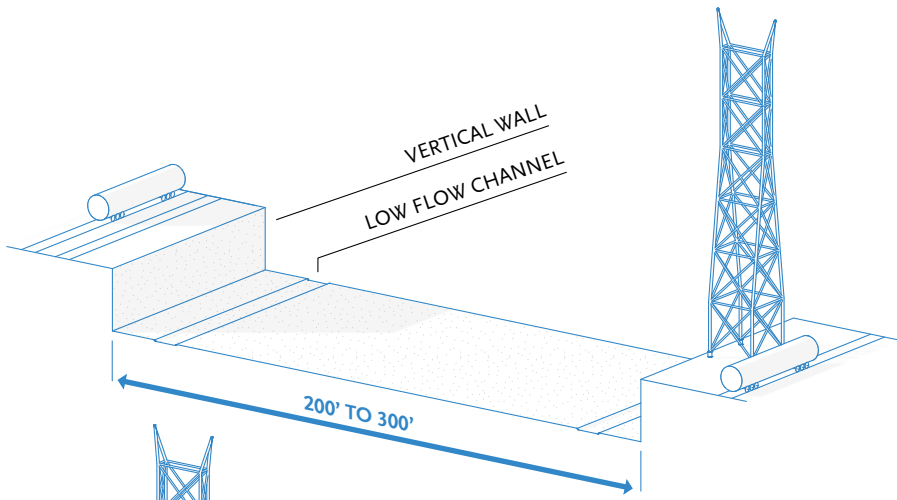

Figure 29. Rectangular

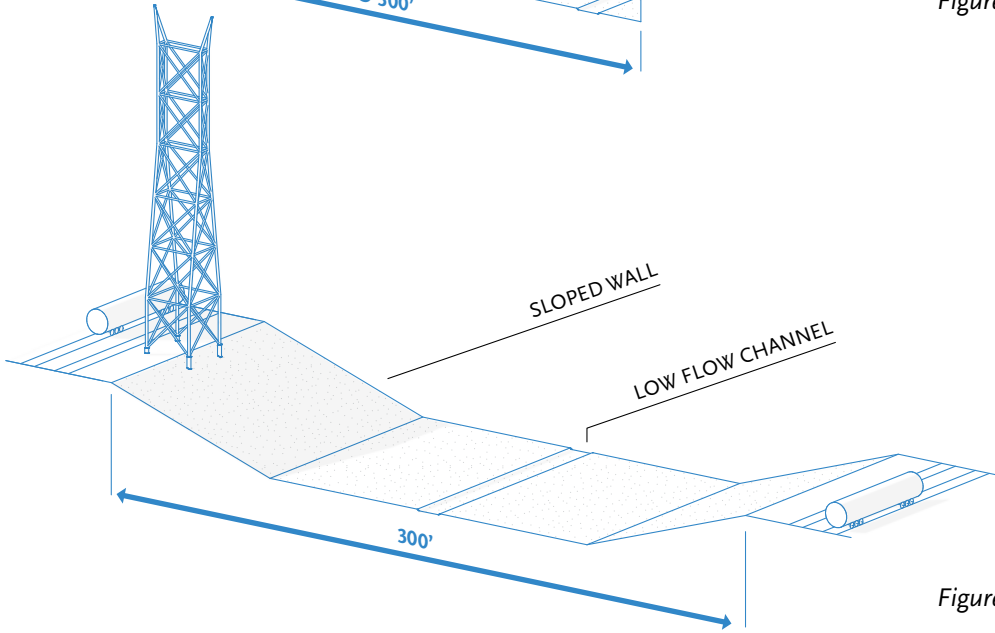

Figure 30. Medium Trapezoid

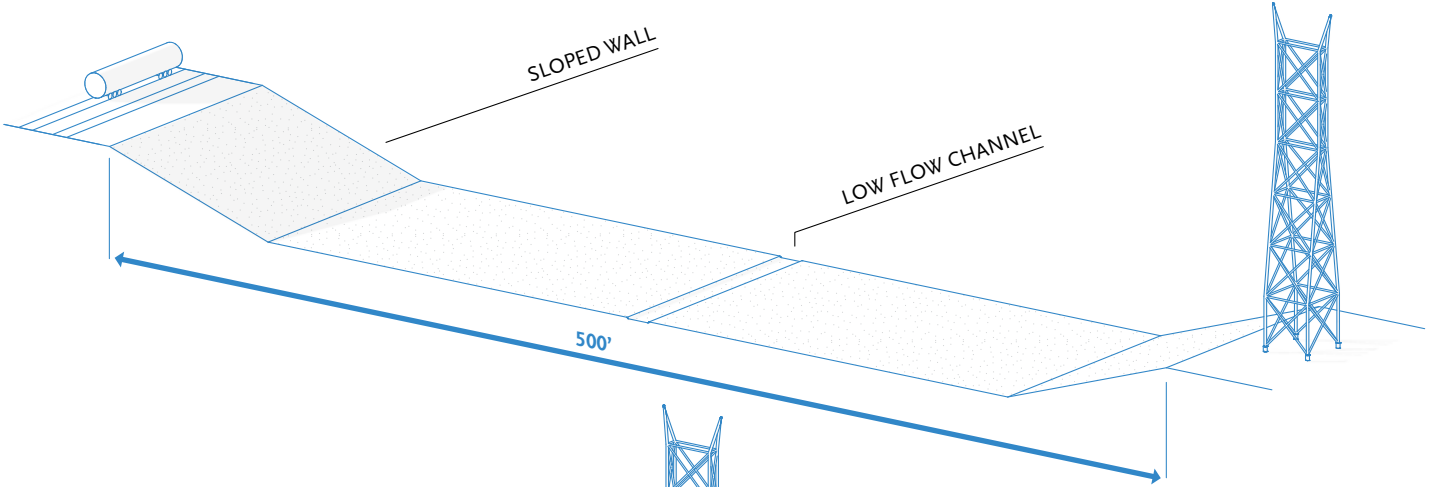

Figure 31. Large Trapezoid

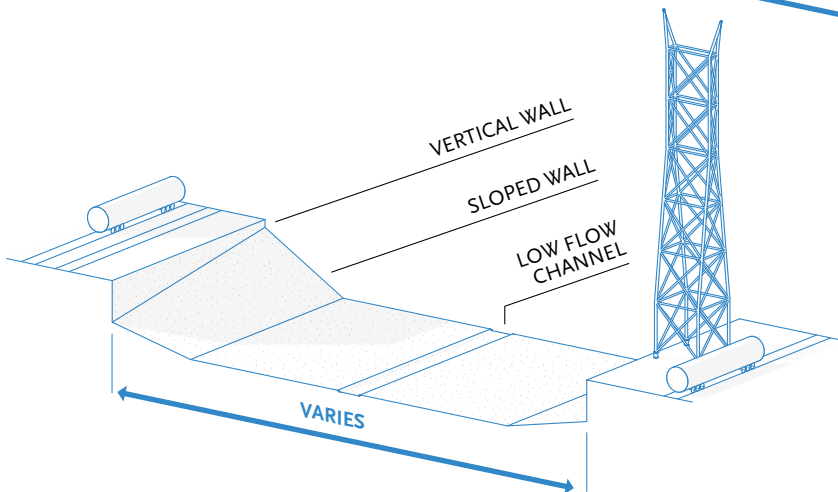

Figure 32. Transitional

Hydrology

Hydrology of the Los Angeles River corridor impacts the LA River Path design in two distinct ways. First, the LA River Path needs to provide a safe and efficient route along the corridor, and locating path types that reduce flood risk will improve path safety and minimize path closures. Second, the Los Angeles River corridor needs to maintain flood control functions, and the path design shall not exceed allowable structural impacts to the channel.

The project team consistently heard feedback from the community on the importance of having a well-maintained, safe, and efficient path that would not be subject to frequent flooding and path closures. This priority also impacted preferences on path types, with 72% of community members selecting a path type that would be open year round as their preferred choice. See Chapter 3 for an overview of community feedback on path vision and priorities and Chapter 9 for a summary of community feedback on path types.

As part of the mission of the agency to reduce risk from disasters, the main goal of the USACE is safety along the Los Angeles River corridor. It is important to maintain flood control for public safety, to protect the neighborhoods surrounding the Los Angeles River from flooding, and to protect the public from flood waters.

The Los Angeles River is 55 miles long with an 824-square-mile watershed ranging from the eastern portions of the Santa Monica Mountains, Simi Hills, and the Santa Susana Mountains in the west to the San Gabriel Mountains in the east. The Los Angeles River originates at the western end of the San Fernando Valley at the confluence of Arroyo Calabasas and Bell Creek. The Los Angeles River watershed consists of approximately 324 square miles of forest and open space. Over half of the watershed is highly developed with commercial, industrial, and residential uses.

Throughout the project corridor, stormwater and other surface water runoff is conveyed to municipal storm drains that eventually drain to the Los Angeles River. The storm drainage system that exists today generally mimics the historic locations of rivers and tributaries in the watershed.



The Los Angeles River is characterized as a seasonal wash, running mostly dry in the summer and intermittently in the winter. During the dry season only a minimal amount of water flows above ground in the channelized river bed. In contrast, during the wet season, with an annual precipitation of 13 to 15 inches that mostly occurs between October and early May, the river flows in intermittent bursts, sometimes violently, following rain events.

In order to analyze the feasibility of constructing a path within the Los Angeles River corridor, USACE HEC-RAS (5.0.7 version) hydraulic

Map 19. Existing Freeboard Conditions

- Minimum freeboard is not met
- LOW: 3 to 4 ft.
- MODERATE: 5 to 10 ft.
- HIGH: > 10 ft.

CHANNEL SHAPE

-  Rectangular
-  Trapezoid

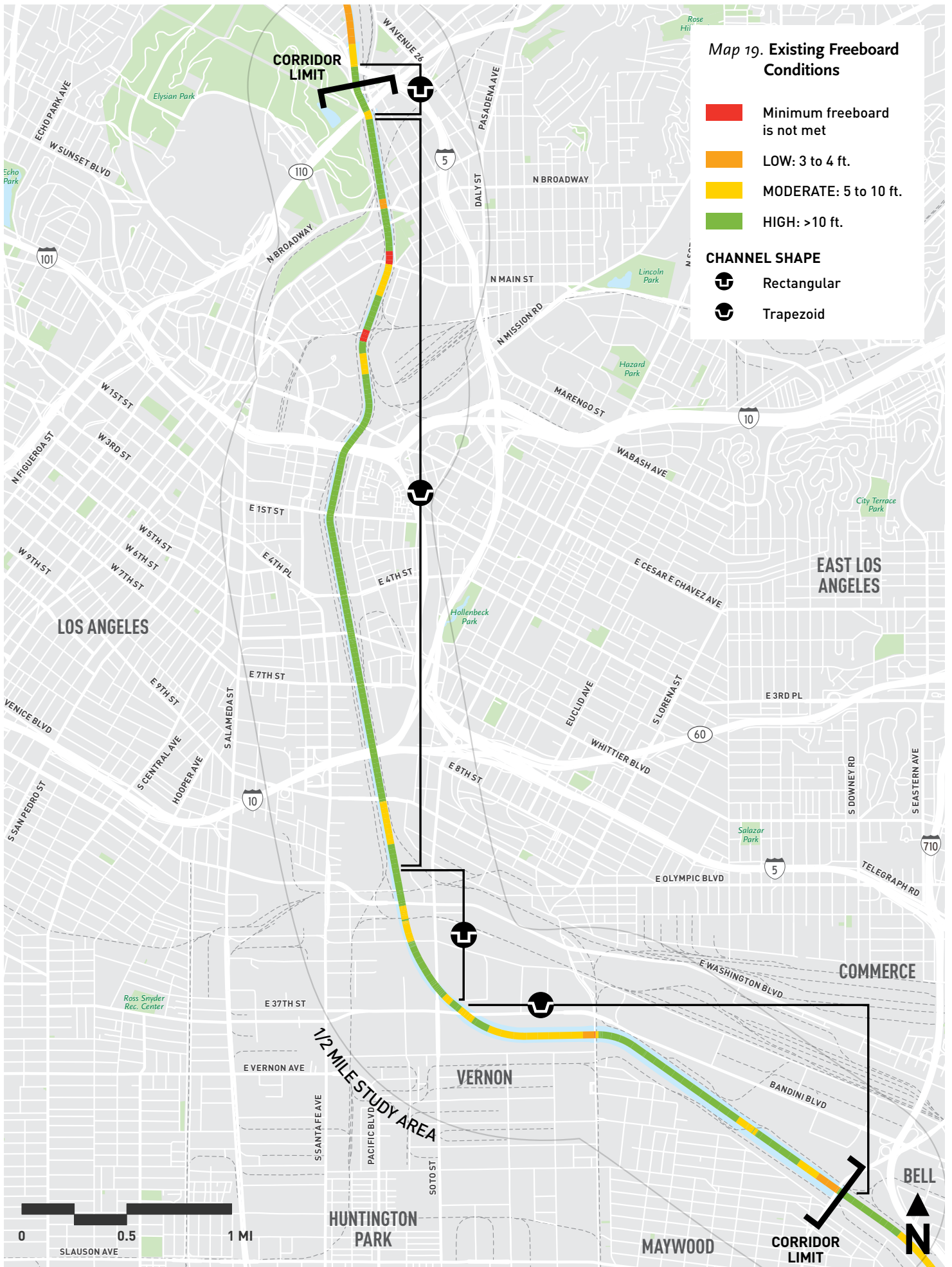

modeling software was used to evaluate the existing hydraulics of the Los Angeles River. The model results provided water surface elevations (WSE), minimum freeboard (a safety factor), channel velocity, and the Froude number along the channel profile (a value that describes open channel flow).

Freeboard is the space between the top-of-bank and the computed WSE. It can be used to identify areas along the channel where the river has relatively more or less hydraulic capacity, or where the channel may have more or less room for the path.

FEMA requires three feet minimum freeboard along the channel and four feet minimum freeboard near bridges. The computed existing freeboards are illustrated in Map 19. Red-colored reaches indicate that minimum freeboard requirements are not met. Orange-colored reaches indicate that minimum freeboard requirements are minimally met. Yellow-colored reaches indicate requirements are met with five to ten feet of freeboard. Green-colored reaches indicate there is greater than ten feet of freeboard.¹

¹ Metro. 2019. *LA River Path Project Water Resources Existing Conditions Assessment*. Los Angeles, CA.

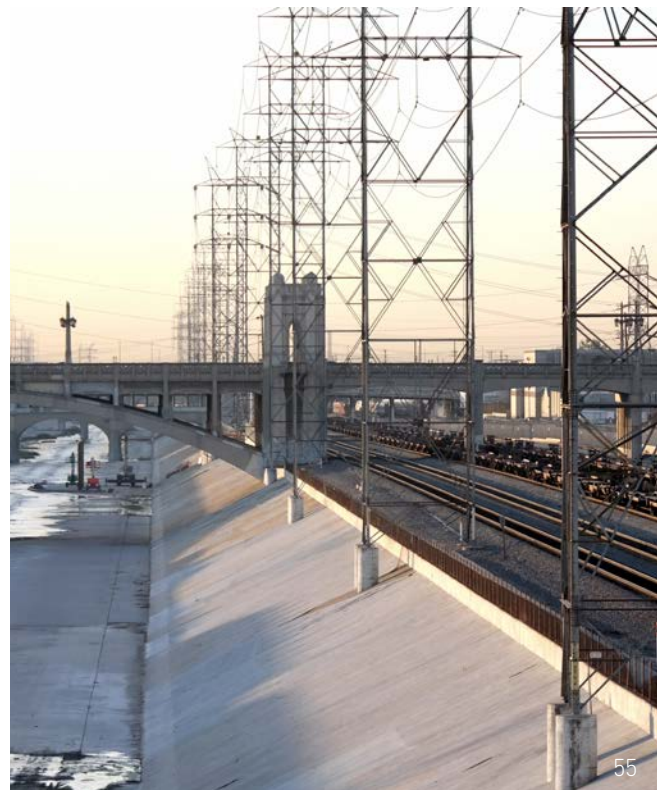

54. LADWP transmission line corridor, Vernon

55. LADWP transmission line corridor near 4th Street, City of Los Angeles

Figure 33.

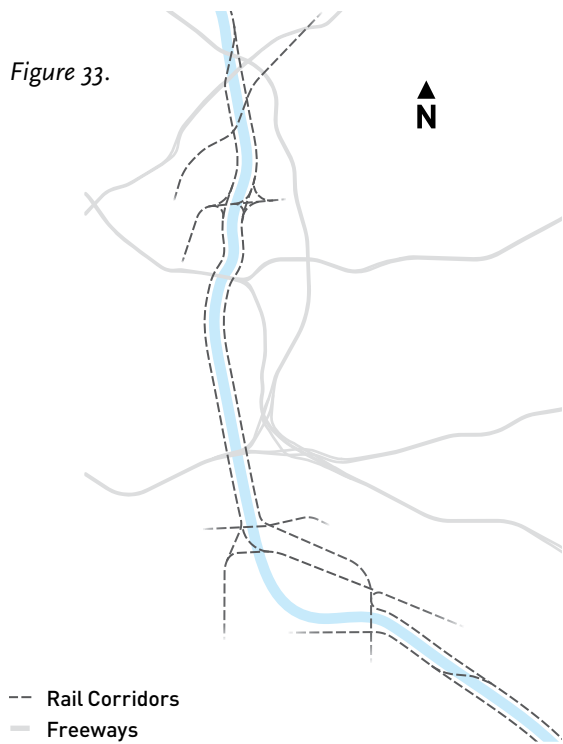

Railways

The Los Angeles River is an important corridor for both commuter and freight railways. They run along both the east and west banks as well as across the river on at-grade and elevated bridges (See Figure 33). Rail owners include Metro, Amtrak, Union Pacific (UP), and Burlington Northern Santa Fe (BNSF). Metrolink is a rail operator in this area as well.

Setbacks limit the available space at top-of-bank for a path, and in many locations will require the LA River Path to be incised, cantilevered, or elevated. Access points that are separated from the path by railways will require ramps that pass up and over the rail. Obtaining the rights to construct and operate in the proposed path under, over, or along rail right-of-way will require coordination with rail owners and operators.

Utility Corridors

Utility corridors run along and across the Los Angeles River, providing power and services to many residential and industrial

Figure 34.

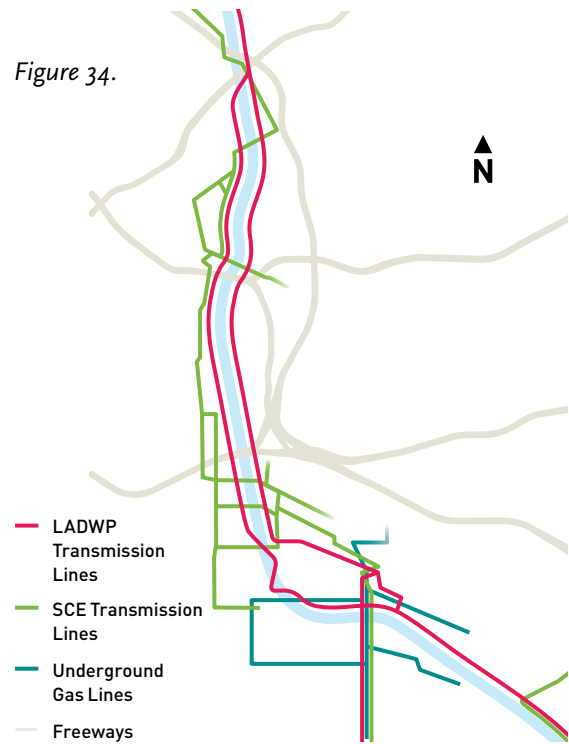

communities. The types of utilities in the area include electric, gas, telecommunications, cable, water, sewer and storm drain, and oil (See Figure 34). Electrical transmission lines in the project corridor are owned by Los Angeles Department of Water and Power (LADWP), Southern California Edison, and the City of Vernon Public Utilities Department. The Los Angeles River is a critical utility corridor for LADWP as it transmits power from a generating station in Seal Beach to a substation in Glendale. Power is carried by overhead lines, mounted on 150-foot-high lattice towers. The path will need to consider the constraints of utility towers along the top of the bank as well as crossing under overhead power lines.

The storm drain outlets within the project corridor vary in size and are operated and maintained by either the City of Los Angeles, Los Angeles County Flood Control District, or Vernon Public Works.¹

¹ Metro. 2019. *LA River Path Project Utilities Existing Conditions Assessment*. Los Angeles, CA.

Figure 35.

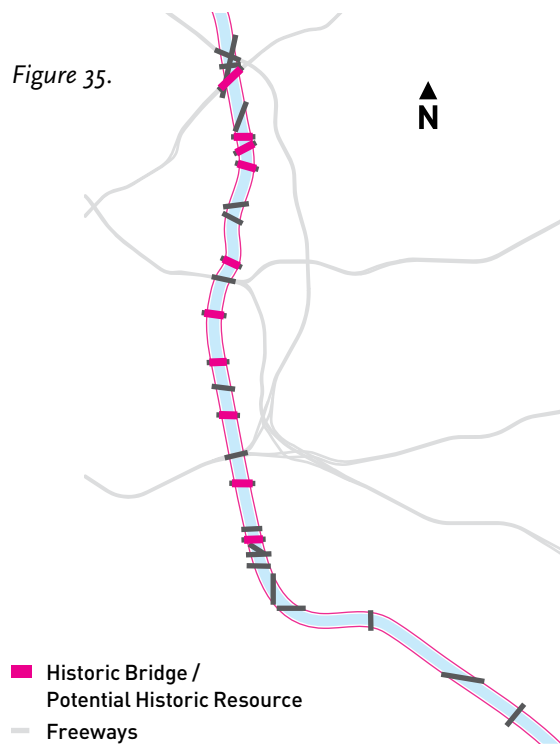

Historic Resources

A “historic resource” is a property that has been listed in or found eligible for listing in a national or state historic register, designated as a local landmark, either individually or as a contributor to a historic district, or has been identified in a historic resources survey. The LA River Path may need to mitigate physical and visual impacts to historic resources, which may influence path type, ramp, and crossing locations.

Figure 35 identifies potential historic resources along the project corridor which include ten historic bridges. Early studies indicate that the Los Angeles River channel itself has not had a formal determination of eligibility for historic designation. Rather, for previous projects that have impacted the river, the channel has often been assumed to be a historic resource for the purpose of environmental review, and project impacts to the channel have been assessed.¹

¹ Metro. 2019. *LA River Path Project Historic Resources Existing Conditions Assessment*. Los Angeles, CA.

Figure 36.

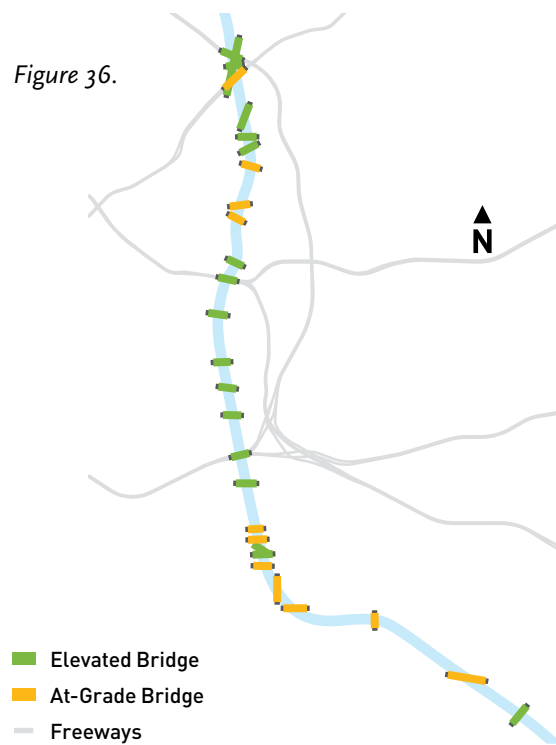

Bridges

There are thirty bridges that cross the Los Angeles River within the project corridor, including bridges for both automobiles and designated railroad bridges. The oldest bridge, the Mission Junction Railroad Bridge North, was constructed in 1902 and the newest bridge, the Sixth Street Bridge, is currently under construction and expected to be completed in 2020. Bridges pose challenges for the LA River Path design as the alignment will have to traverse over, under, to, or through the existing structures. The majority of the bridges are elevated over the channel. Eleven bridges cross the channel at-grade (See Figure 36).²

² Metro. 2019. *LA River Path Project Structures Existing Conditions Assessment*. Los Angeles, CA.

Photos, opposite (all Los Angeles River, CA):

56. 1st Street Bridge

57. 4th Street Bridge

58. Olympic Boulevard Bridge



56



57



58

Property Ownership

The land along the corridor includes publicly and privately held property, both within the river channel and along the top-of-bank (see Map 20). The channel itself is owned in large part by the City of Los Angeles north of Washington Boulevard and by the Los Angeles County Flood Control District (LACFCD) south of S. Downey Road. The section between contains a number of privately owned properties, many of which are adjacent industrial properties with parcel boundaries that extend into the channel itself. Private industrial uses, railroads, and utilities dominate the ownership immediately adjacent to the channel. Metro owns approximately 98 miles of rail, operated by Metrolink, immediately adjacent to the Los Angeles River channel, the Gold Line which traverses the river, as well as large parcels adjacent to the river containing Union Station and operational facilities from Mission Junction south of Main Street to 6th Street.

The USACE and LACFCD hold flood control easements throughout the LA River Path project corridor. The easements extend beyond the channel along the top-of-bank. The Los Angeles County Flood Control Act (Assembly Bill 2554) allows the LACFCD to enhance and add recreational features to its properties, which has often been put to use to develop existing segments of the LA River Path along the river. Exploring options to use joint use agreements between LACFCD and agency land owners (such as Metro or USACE) may be a strategy to allow construction and operation of the path within the right-of-way it owns. The Compton Creek Trail is an example of a joint agreement between USACE, LACFCD, and the City of Compton.¹

¹ Metro. 2019. *LA River Path Project Right-of-Way Existing Conditions Assessment*. Los Angeles, CA.

Map 20. Rights-of-Way

OWNERS

- LACFCD
- LADWP
- City
- Metro
- Railroad
- Other Government
- Private Owner

EASEMENTS

- LACFCD Easement
- USACE Easement

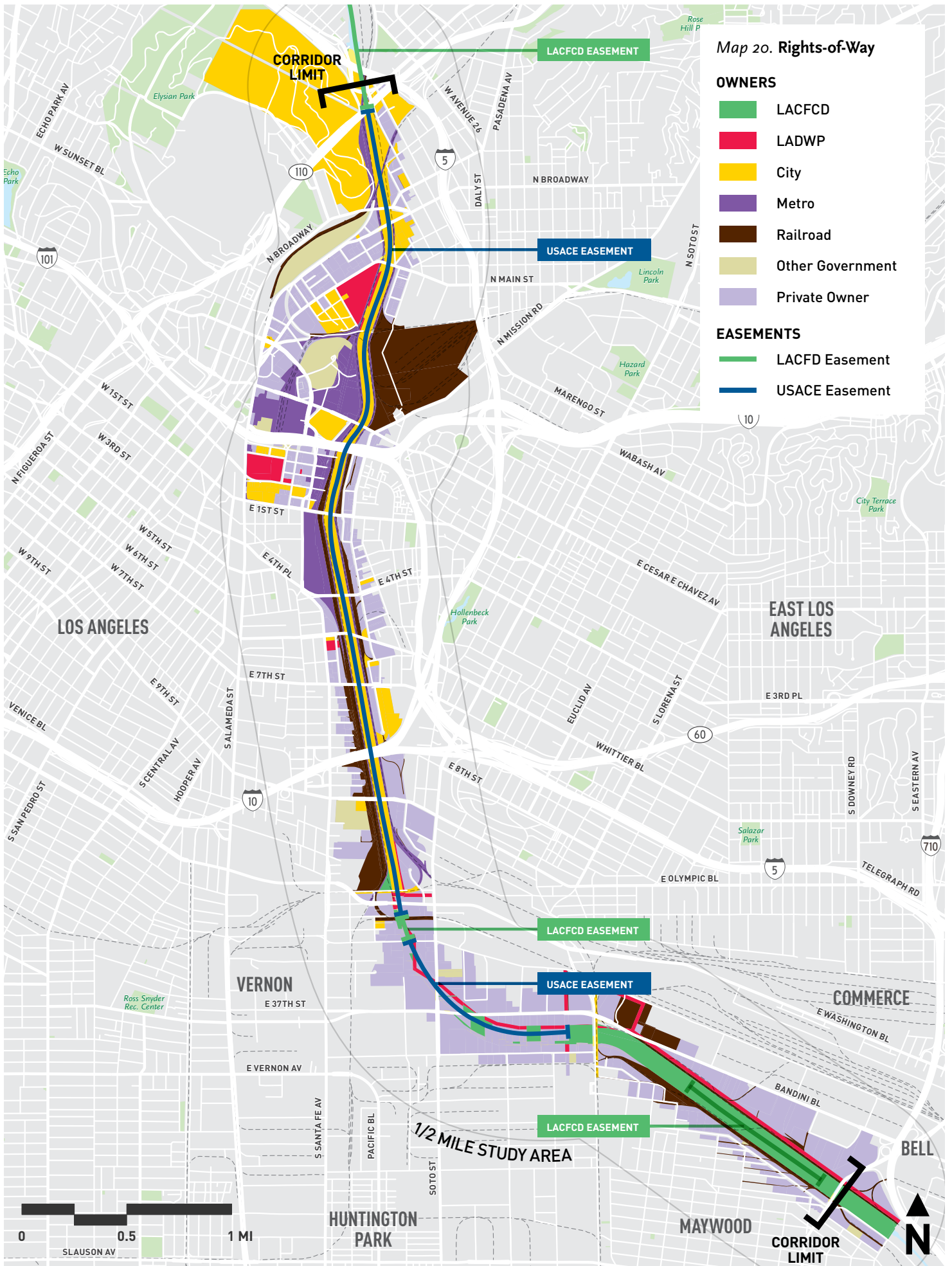

Hazardous Materials

Hazardous materials from current and historical land uses are present throughout the assessment area (see Map 21). Parcels with hazardous materials will influence where the LA River Path is located, and contaminated parcels will require remediation or be avoided altogether. Past and current land uses include light and heavy industry and manufacturing, metal processing plants, battery recycling facilities, auto-related businesses, and shipping yards, in addition to commercial, residential, and open space zoning.

Public and commercial buildings are common throughout the study area, many of which were built prior to the 1970s, when asbestos and lead-based paint were commonly used in building materials.

Various chemicals were historically used to preserve railroad ties and for weed abatement along railroad tracks. In addition, leaks, spills, and drips of various hazardous substances and petroleum products may have occurred throughout the project corridor. Due to the close proximity to several nearby highways, elevated concentrations of aerial-deposited lead (ADL) may be present in the soil along the corridor.

Public utilities, such as crude oil, natural gas, and hydrocarbon product pipelines, are present throughout the study area and contaminants may be present in soil and groundwater.

Hazardous subsurface gases, such as methane and hydrogen sulfide, may pose a hazard during construction and operation of the project.

Environmental site assessment investigations will be performed during conceptual engineering to determine impacts and potential mitigation measures. Proper mitigation measures will ensure that there is no risk of contamination once the path opens. Environmental concerns were assessed for parcels within 500 feet on either side of the project corridor. Map 21 shows the ranking ranging high (known hazardous material record or high likelihood of volatility based on land use) to low (business, government, or residential).¹

¹ Metro. 2019. *LA River Path Project Hazardous Materials Existing Conditions Assessment*. Los Angeles, CA.

Map 21. Hazardous Materials Concern Rank

- Low
- Medium
- High
- Unknown

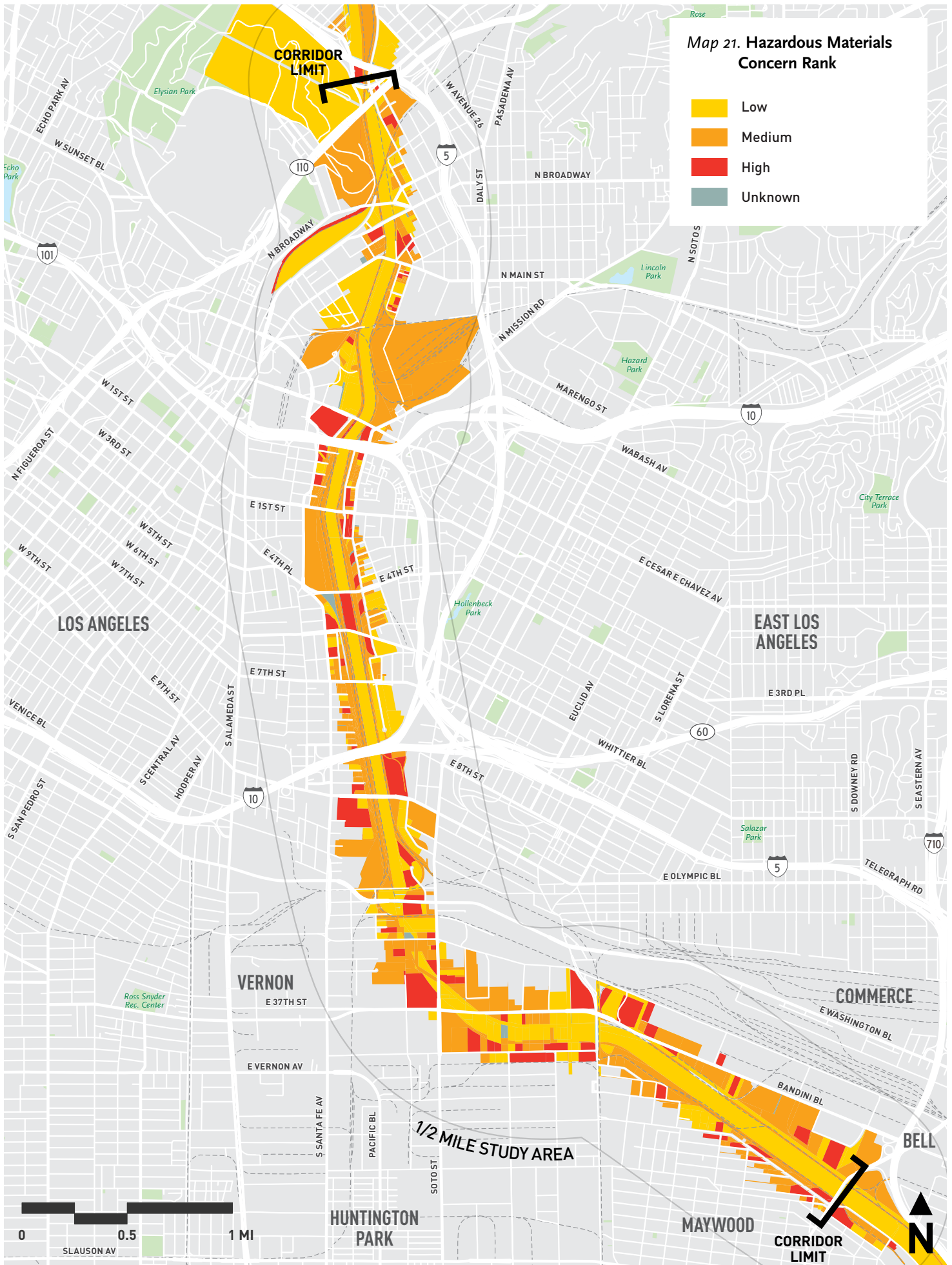

Geotechnical

The primary geotechnical, subsurface, and seismic existing conditions which could impact the design, construction, and operation of the project are the presence of naturally occurring oil and gas, shallow groundwater conditions and loose alluvial sediments. These conditions could impact the design and construction of foundations and pavements. In addition, design features could be impacted by seismic shaking and its secondary effects—including liquefaction and lateral spreading. As the project moves forward a comprehensive geologic and geotechnical investigation will be conducted, and design level geotechnical reports will be prepared to inform pathway design.¹

Biological Resources

The majority of the LA River Path corridor is surrounded by a highly developed urban landscape. Existing vegetation is sparse, highly disturbed, fragmented, and dominated by native plants. In the northern section of the project corridor, Southern California black walnut trees grow along the top of the western channel bank, in addition to willows, cottonwoods, and palm trees.

The project corridor is home to several bird and animal species. Historically, the Los Angeles River supported several species of native fish including the endangered Southern California steelhead, the endangered unarmored threespine stickleback, the threatened Santa Ana sucker, and others including the arroyo chub and Santa Ana speckled dace.

The Los Angeles River provides a perennial source of water along its course due to urban runoff, discharges from publicly owned treatment works, and high-volume storm flow during rain events. Within the project corridor, sections of the river do not meet water quality standards due to point and non-point sources of levels of impairments such as chemicals, oil, algae, and trash.

Currently, there are only limited opportunities for people to access the river, whether for relaxation, fishing, bird watching, or other recreational uses. The USACE is leading the Los Angeles River Ecosystem Restoration Project, an ongoing process that seeks to restore 11 miles of the Los Angeles River from the Griffith Park area through downtown Los Angeles. The restoration measures include creation and reestablishment of riparian and marsh habitat, reintroduction of ecological and fluvial processes, as well as opportunities for passive recreation compatible with the restored environment. A number of community members reported a desire to more closely access the river and its natural resources (see Chapter 3).

The LA River Path will be constructed within this dense and thriving urban corridor. This preliminary assessment of existing and potential biological resources within the assessment area provides an initial identification of potential impacts to biological resources that could occur from construction of the path. Further review of potential impacts and ways to avoid or mitigate them will be evaluated during the environmental review phase of the project.²

¹ Metro. 2019. *LA River Path Project Geotechnical, Subsurface, and Seismic Existing Conditions Assessment*. Los Angeles, CA.

² Metro. 2019. *LA River Path Project Biological Existing Conditions Assessment*. Los Angeles, CA.

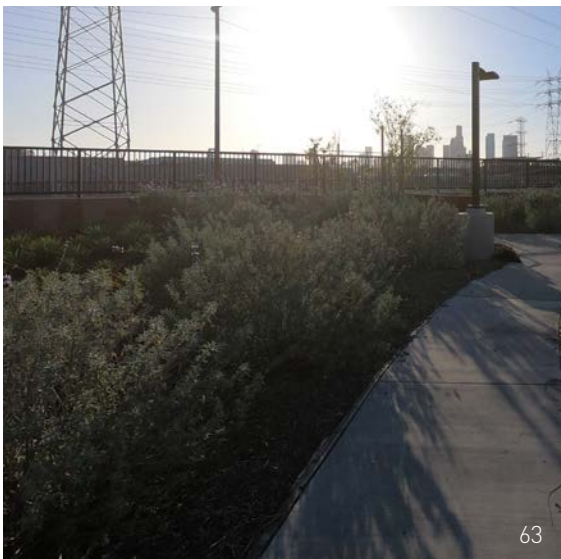
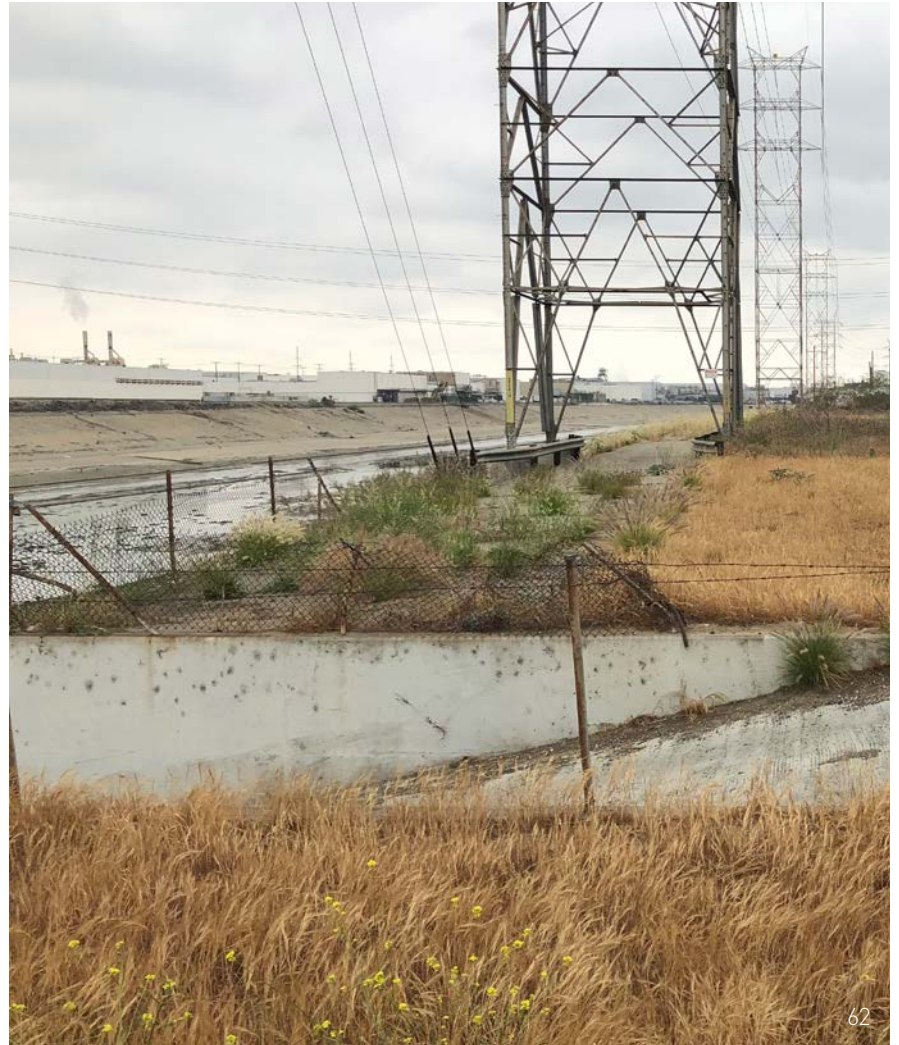
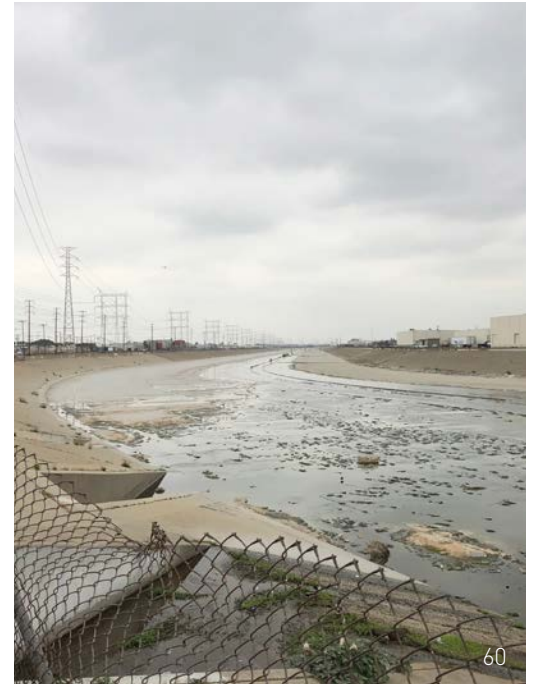

59. Plant life adjacent to the Los Angeles River, Elysian Valley, CA.

60. Algae growth in-channel, Vernon, CA.

61. Algae growth in-channel, Redondo Junction, CA.

62. Vegetation along the existing path in Vernon, CA.

63. Path landscaping in Boyle Heights, CA.

OPERATIONS AND MAINTENANCE

LA River Path Existing O+M

Three agencies conduct O+M on the existing LA River Path: the City of Los Angeles, Los Angeles County, and the Mountains Recreation and Conservation Authority (MRCA).

The City of Los Angeles Department of Transportation (LADOT) oversees O+M for the Los Angeles River Greenway Trail within city limits. However, several city departments contribute to overall O+M, leading to a complicated O+M structure (see case study, page 88).

Funding for the Los Angeles River Greenway Trail O+M in the City of Los Angeles comes from the Transportation Development Act, Article 3 (TDA3). This program, administered by Metro, allocates funds annually on a per-capita basis to cities and the county government in Los Angeles County. Funds can be used for planning, constructing, and maintaining regionally significant bikeways.

O+M for the Los Angeles River Bicycle Path along the lower Los Angeles River (south of Atlantic Boulevard) is managed by the Los Angeles County Department of Public Works (LACDPW) Bikeways Unit. The lower LA River Path is overlaid on the channel maintenance path used by the Los Angeles County Flood Control District (LACFCD). The principle function of this path is to provide access to the channel for flood control maintenance. O+M requires coordination between LACDPW Bikeways Unit and LACFCD.

MRCA manages numerous parks along the Los Angeles River from the San Fernando Valley to downtown Los Angeles. MRCA also manages two recreation zones on the river which allows for kayaking and fishing in the designated zones during favorable conditions in the summer. MRCA supports the City of Los Angeles' O+M through its River Ranger pilot program. In the northern reach of the river, the River Rangers contribute to safety patrol, emergency medical aid, public outreach, law enforcement, natural resource management, and interpretation. MRCA is currently coordinating efforts with the 22 cities along the Los Angeles River to expand the River Ranger program.

Los Angeles River Greenway Trail Case Study

The 7.4-mile Los Angeles River Greenway Trail connects the northern end of the LA River Path at Riverside Drive with the border of Burbank and Glendale. A number of Los Angeles city departments are involved in its maintenance, resulting in a complex structure.



64. Los Angeles River Greenway Trail, Los Angeles, CA

CURRENT MANAGEMENT STRUCTURE

The City of Los Angeles Department of Transportation (LADOT) oversees O+M for the Los Angeles River Greenway Trail within city limits.

Several city departments, including the Bureau of Engineering (BOE) and Department of Recreation and Parks, contribute to overall O+M, leading to a complicated O+M structure.

- LADOT provides routine maintenance such as replacing signs, striping, and crack repair
- A LADOT contractor performs remedial maintenance such as paving repair and replacement
- A LADOT contractor performs daily maintenance, such as sweeping and vegetation management, ensuring the path is free of debris
- BOE's Structures team conducts bridge inspections and repairs
- The Department of Recreation and Parks provides maintenance in areas with more intensive landscaping and site elements
- Contracting maintenance services with a private contractor. The contractor is scoped to sweep the path twice a week, and make weekly inspections for trash and graffiti removal.

CLOSURE STRUCTURE

The Los Angeles River Greenway Trail is primarily located at the top-of-bank, with incised portions underneath bridges. Unlike the Arroyo Seco Bike Path which closes at the prospect of rain, the Los Angeles River Greenway Trail closes only during major rain events.

CURRENT CHALLENGES

The two largest challenges facing operating and maintaining the LA River Path today include people experiencing homelessness along the path and the complex O+M structure in both the City of Los Angeles and County. These concerns were also heard from the community throughout the conceptual design phase. Community members repeatedly reported the need to have a safe, well-maintained path, and noted that encampments along the path make the path feel less safe for users.

The City of Los Angeles' Homeless Outreach and Proactive Engagement (HOPE) Team is a collaborative effort between the Los Angeles Police Department (LAPD), Department of Sanitation, LADOT, Los Angeles Homeless Services Authority (LAHSA), Office of the City Attorney, and the Mayor's Office. The HOPE Team proactively addresses the needs of the homeless by responding to the complex and diverse needs of unsheltered residents who may be residing along the river. This contributes to helping to provide a safe and enjoyable experience for LA River Path users.

Additionally, Metro's Homeless Task Force provides specific guidance for Metro facilities. Metro works with the Los Angeles County Department of Mental Health (LACDMH), LAHSA, and Los Angeles County Sheriff's Department (LASD) to respond to homelessness by working with homeless populations and connecting them to services.

The agencies who operate and maintain the LA River Path today acknowledge the complex and inefficient nature of the current O+M strategy. The challenges of the current strategies can lead to deferred maintenance which degrades user experience as well as contributes to more expensive future repairs.

The Arroyo Seco Bike Path (see case study, page 90) is a local example of a bottom-of-channel path, which provides insight into the existing O+M challenges of path implementation on the channel bottom.

The development of an O+M Plan for the LA River Path project, informed by continued stakeholder and community feedback, will continue into the next phase of the project in order to ensure a safe and well-maintained facility for all path users. More information on the O+M Plan for the LA River Path project can be found in Chapter 2.

Arroyo Seco Bike Path Case Study

In 1983, Los Angeles County built a two-mile shared-use path at the bottom of the cement-lined Arroyo Seco. Because the path is along the channel bottom, it has special maintenance considerations to keep the path free of debris and it has experienced closures limiting its use as a reliable active transportation corridor.



65. Arroyo Seco Bike Path, Arroyo Seco, CA

CURRENT MANAGEMENT STRUCTURE

The path facility is maintained by both the City of Los Angeles and the LACDWP.

The LACDWP manages the channel for flood protection. LACDWP is responsible for:

- The channel itself
- Closing the gates to the path whenever there is a chance of rainfall greater than 0.25 inches, or any discharge from the Devil's Gate Dam upstream
- Managing illegal dumping in the channel through the Clean Los Angeles program and hotline

The City of Los Angeles maintains the bicycle and pedestrian path. City of Los Angeles is responsible for:

- Pathway general maintenance
- Cleaning up deposition of materials (rocks, granite, etc.) after rainfall
- Contracting maintenance services with a private contractor. The contractor is scoped to sweep the path twice a week, and make weekly inspections for trash and graffiti removal.

CLOSURE STRUCTURE

Due to flash flood risks, LACDWP closes the path at the prospect of rain, or a release from the Devil's Gate Dam. Closure is based on a combination of predicted rainfall amount and an estimate of watershed saturation. This presents safety and logistical challenges:

- Closures must be closely coordinated with discharges from the Devil's Gate Dam, which are made both during and following storms. Annual closures due to dam releases range from one to 52 days per year, depending on rainfall.
- The LACDWP estimates that a rainfall of 0.25" would result in channel water flows of 150 cubic feet per second and trigger a path closure. This occurs an average of 14 days per year.
- The City of Los Angeles is not always available to clear and clean the path immediately after the gates are re-opened. After rain, path users often encounter dirt, granite, and other debris until they are cleared.
- It is difficult to ensure that no one has entered the path before closing the gates. A person could inadvertently be locked into the channel as gate closures are sometimes sporadic.
- Frequent closures pose a challenge to the path's ability to function as a reliable transportation alternative.



06

PATH DESIGN

Why is this important?

The path design guidance draws on best practices, design standards, and innovative precedents to create design solutions for the unique and complex environment of the channel.



How does it apply to the LA River Path?

Throughout the corridor, the path design will change to respond to constraints and needs of various locations. It is important to identify existing pathway standards and guidance. It is also important to understand the benefits and trade-offs for each path type, in addition to elements that will contribute to the path experience, such as crossings, bridges, and technology.

Chapter 6 explains the path design approach and illustrates the design principles that may be used along the path, as well as potential path typologies that may be implemented.

GUIDANCE RESOURCES

These design guidelines serve as an inventory of path design treatments and provide conceptual guidance for their development. These treatments and design guidelines are important because they are the tools for creating a safe and outstanding user experience for people walking, bicycling, and connecting to transit. The guidelines set the framework for the path design to achieve the project goals. The guidelines are not, however, a substitute for a more thorough evaluation by a landscape architect or engineer.

The LA River Path will be designed for people walking, bicycling, and rolling, as well as for all ages and abilities. The path is also expected to be used for a variety of purposes, including transportation and recreational trips.

The LA River Path will be designated as a Class I bikeway. Class I bikeways are bicycle paths that are completely separated from roadways and can be shared with pedestrians, sometimes referred to as multi-use or shared-use paths.¹

Existing Guidance

NATIONAL GUIDANCE

The Federal Highway Administration's Manual on Uniform Traffic Control Devices (MUTCD) was amended by Caltrans for use in California. The CA MUTCD provides uniform standards and specifications for all official traffic control devices in California.

The American Association of State Highway and Transportation Officials (AASHTO) Guide for the Development of Bicycle Facilities (2012)² is currently under update with a new and expanded edition due out in 2020, but still serves as one of the main resources of design guidance. The guide documents best practice for on-street and off-street (path) facilities, as it relates to the operational and safety characteristics of different facility user types.

The National Association of City Transportation Officials' (NACTO) Urban Bikeway Design Guide (2012) is the newest publication of nationally recognized bikeway design standards, and offers guidance on current state-of-the-practice designs for on-street bicycle facilities.

The U.S. Army Corps of Engineers (USACE) manages and operates the Downtown Los Angeles portion of the Los Angeles River for flood control purposes. Guidelines for Landscape Planning and Vegetation Management at Levees, Floodwalls, Embankment Dams, and Appurtenant

¹ Caltrans Highway Design Manual 1002.1 + 1003.1

² Update expected 2019

Structures provides guidance to ensure that the safety, structural integrity, and functionality of the stormwater channel are retained and that accessibility for maintenance, inspection, monitoring, and flood control are not compromised.

The ADA Accessibility Guidelines (ADAAG) are design guidelines developed and updated by United States Access Board, an independent federal agency, created in 1973 to ensure access to federally funded facilities. The U.S. Department of Justice (DOJ) and U.S. Department of Transportation (DOT) each have similar ADA Standards based on the ADAAG. The DOJ's standards apply to all facilities except public transportation facilities, which are subject to DOT's ADA standards.

The United States Access Board is developing guidelines for public rights of way, referred to as PROWAG. Once these guidelines are adopted by the DOJ, they will become enforceable standards under title II of the ADA. The Board's aim is to ensure that access for persons with disabilities is provided wherever a pedestrian way is newly built or altered, and that the same degree of convenience, connection, and safety afforded to the public generally is available to pedestrians with disabilities.

INTERNATIONAL GUIDANCE

Ipv Delft (an internationally celebrated bridge design firm in the Netherlands and member of the project team) wrote the Dutch Design Guide for Bicycle and Pedestrian Bridges, published in 2014. With portions of the LA River Path project anticipated to be on-structure, this international guidance helps the project to remain on the cutting edge of best practices and innovation.

In addition to this bridge-specific design guidance, the Dutch CROW Manual and Danish Collection of Cycling Concepts provide further international best practice and design direction for on-street and off-street bicycle facilities, including transitions, shared spaces, gradients, wayfinding, and other elements.

STATE GUIDANCE

Caltrans (California Department of Transportation)

Caltrans manages over 50,000 miles of highway and freeway lanes throughout California and operates programs in highway transportation, mass transportation, transportation planning, administration, and an equipment service center. Key guidance relevant to the LA River Path includes Highway Design Manual (HDM)

Chapters 200 (Geometric Design and Structure Standards) and 1000 (Bicycle Transportation Design) as well as AASHTO LRFD Bridge Design Specifications: Sixth Edition with California Amendments.

California Public Utilities Commission

The California Public Utilities Commission (CPUC) regulates privately owned electric, natural gas, telecommunications, water, railroad, rail transit, and passenger transportation companies, and provides design guidance for development adjacent to utilities in the form of General Orders. General Order (GO) 26-D offers guidance for rail. GO 95 offers guidance for overhead electric utilities.

LOCAL GUIDANCE

County

The Los Angeles County Bicycle Master Plan (2012) is an adopted regional planning document that guides the County in implementing proposed bikeways, as well as policies and programs to promote bicycle ridership. The Bicycle Master Plan proposes approximately 831 miles of new bikeways throughout the county (on unincorporated streets and separated paths) for implementation through 2032. The Design Guide section of the plan provides an overview of design guidelines based on national and local guidance and best practice.

Los Angeles County Trails Manual (2013) is a document created by the County's

Department of Parks and Recreation and only applies to County-owned trails and paths.

The Trails Manual provides County staff and developers with guidelines and standards for trail and path planning, design, development, and maintenance of County-owned trails.

City

The City of Los Angeles' Urban Design Studio works with other city departments, regional agencies, the broader design community, developers, non-profits, and community-based organizations to elevate the quality of design in the city. The Studio's Urban Design Principles (2011) provide a framework for "Rebalancing the needs of pedestrians, mass transit users and drivers, the importance of open space and protecting the health and well-being of residents and our urban ecology".

The City of Los Angeles' Complete Streets Design Guide (2014) provides design concepts and best practices that promote safety and accessibility, and is meant to supplement existing engineering practices and requirements in order to meet the goals of Complete Streets.

Los Angeles DOT People Street Kit of Parts for Parklets (2015) provides guidance on small-scale public space and may provide applicable design guidance to the access points along the LA River Path.

The City of Vernon's LA River Path Feasibility Study (2017) provides a path design and vision for the three-mile section of the LA River Path through Vernon.

METRO GUIDANCE

Metro Signage Standards

Metro's Signage Standards (2016) are basic guidelines that are intended for jurisdictions or other transit operators who are implementing wayfinding systems to guide users to Metro stations. The sign drawings and specifications provide basic station wayfinding signage guidelines.

Metro Adjacent Development Handbook

The Metro Adjacent Development Handbook (2018) provides guidance to local jurisdictions and developers constructing on, adjacent, over, or under Metro rights-of-way, non-revenue property, or transit facilities.

Metro's Kit of Parts

Metro's "kit of parts" station design standards (2018) feature components that seek to keep Metro stations and structures consistent in their appearance. The station designs improve the legibility of Metro's rail system, improve the maintainability of the stations, and are cost effective. The document provides a precedent for suitable materials and guidance for integrating path design with Metro stations.

Transit Oriented Communities Policy

Metro's transit oriented communities (TOCs) policy redefines the role of the transit agency by expanding mobility options, promoting sustainable urban design, and helping transform communities. The policy aims to achieve housing affordability and economic vitality at transit hubs throughout Los Angeles County.

Active Transportation Strategic Plan

Metro's Active Transportation Strategic Plan (ATSP) 2016 includes strategies to increase walking, bicycling, and transit use countywide through policy and infrastructure recommendations. The ATSP is focused on improving first and last mile access to transit and proposes a regional network of active transportation facilities, including shared-use paths and on-street bikeways.

Active Transportation Rail to River Corridor

The Active Transportation Rail to River Corridor Project, spanning approximately 10 miles, will convert an existing, underutilized railroad right-of-way into a path for walking and bicycling stretching from South Los Angeles to the Los Angeles River, connecting to the LA River Path and enhancing regional connectivity. The first phase, Rail to River, is in final design and serves as an active transportation precedent.

PATH USERS

Path Users

Path designs should be based on the intended user types, and anticipated volumes and speeds. Path users include people walking (including those using mobility devices or pushing strollers), people rolling (such as scooters and skateboards), and people bicycling. People with vendor carts may also potentially use this path. Understanding the unique characteristics and needs of all path users is critical when designing quality facilities that minimize user risk.

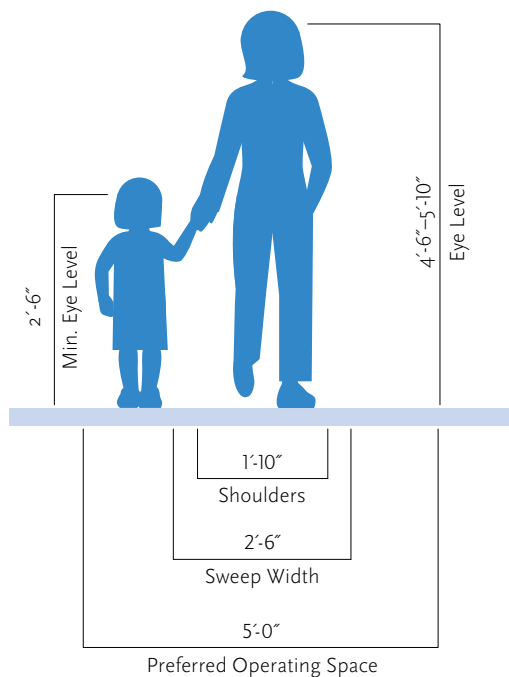

DESIGN NEEDS OF PEOPLE WALKING

People walking have a variety of characteristics and the path network should accommodate a variety of needs and abilities.

Age is a major factor affecting pedestrians' physical characteristics, walking speed, and environmental perception. Children generally have lower eye height and walk at slower speeds than adults. They also perceive the environment differently at various stages of their cognitive development. Older adults walk more slowly and may require assistive devices for walking stability, sight, and hearing.

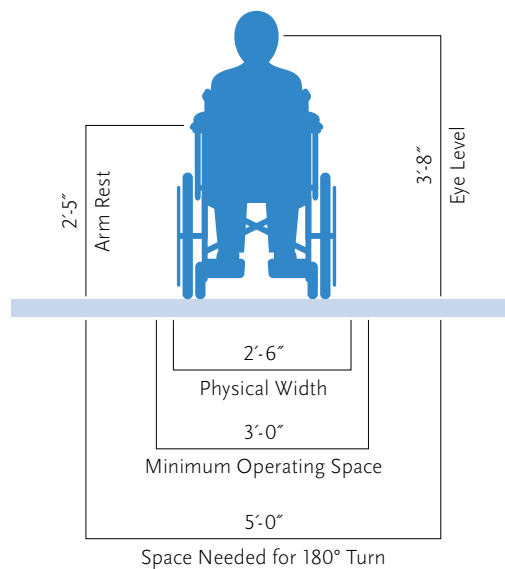

DESIGN NEEDS OF PEOPLE USING A WHEELCHAIR

Manual wheelchairs are self-propelled devices that can also be controlled by a second individual using handles attached to the back of the chair.

Powered wheelchairs and other electric mobility devices have larger physical dimensions than manual wheelchairs, and use battery power to move the wheelchair. The size and weight of powered wheelchairs limit their ability to negotiate obstacles without a ramp. Various control units are available that enable users to control the wheelchair movement, based on their ability such as a joystick control or breath control.

Maneuvering around a turn requires additional space for wheelchair devices. Providing adequate space for 180 degree turns at appropriate locations is an important element of accessible design with minimum 3-foot clearance between obstacles.¹

¹ AASHTO *Guide for the Development of Bicycle Facilities*

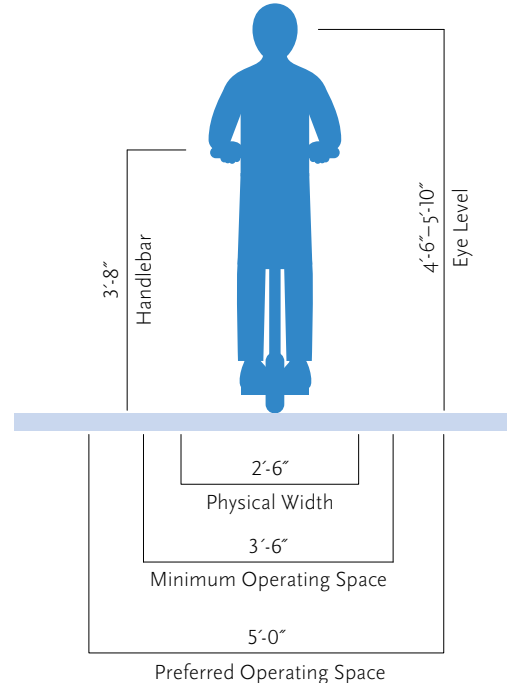
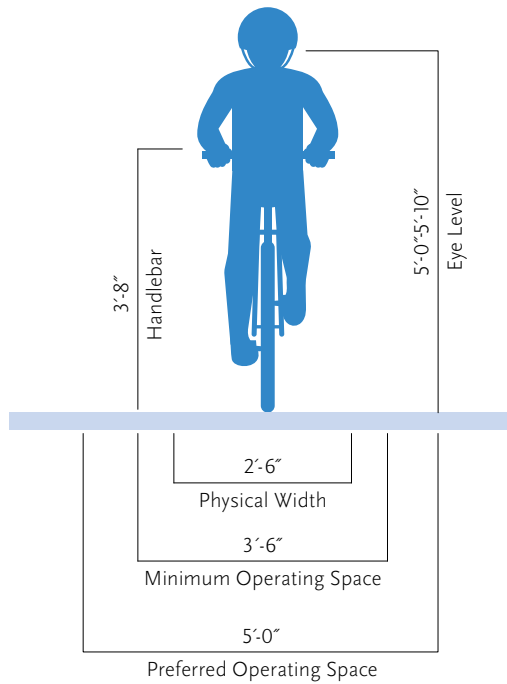

DESIGN NEEDS OF PEOPLE BICYCLING

People bicycling and their bicycles exist in a variety of sizes and configurations. These variations occur in the types of bicycle (such as a conventional upright bicycle, a recumbent bicycle or a tricycle), and behavioral characteristics (such as the comfort level and experience of the person bicycling). The path design should consider reasonably expected user types and utilize the appropriate design dimensions and standards. People bicycling differ from people walking in several ways, such as moving at a faster pace and generally having a higher center of gravity. Design of path curves is important for people bicycling, as are the design of ramps, grade changes, and path surface transitions.

DESIGN NEEDS OF PEOPLE ROLLING

Scooters, skateboards and other micro-mobility devices (MMD) are low-speed mobility devices operated on on-street facilities. MMD can be entirely human-powered, powered by an electric motor, or a hybrid of the two, but typically have a speed of 20 mph or less. Because the speed of these devices is similar to bicycles, they are often operated in bicycle facilities (on-street and off-street).

In general, these devices have the same design and operating envelopes of bicycles (in some cases even narrower), and can be operated by a wide range of users, including those who may not be able to operate a traditional bicycle.

The cost of these devices continues to decrease, making them more accessible. Beyond personal ownership, MMD for public use continues to expand with scooter-share systems being implemented in many cities across the country.

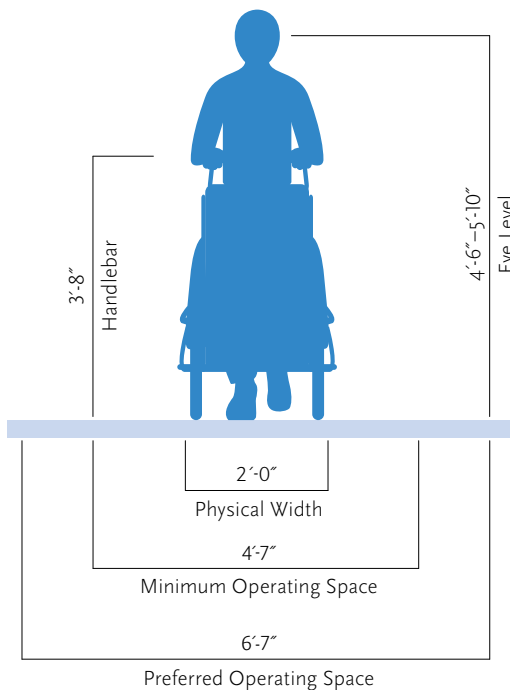
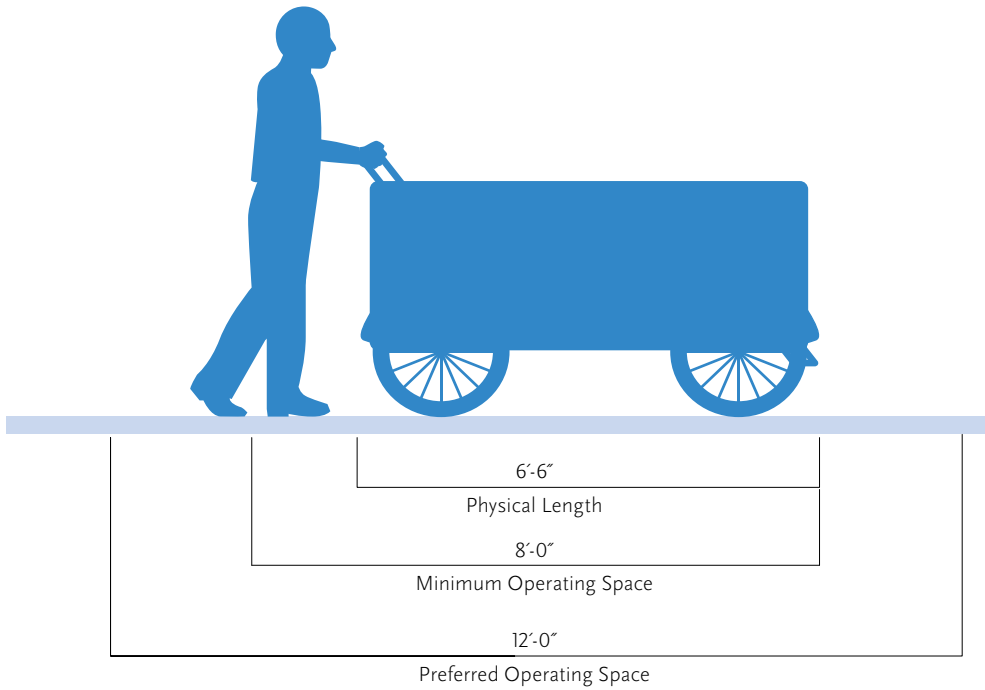

DESIGN NEEDS OF PEOPLE WITH VENDOR CARTS

Vendors with carts are potential users along the LA River Path. Vendors provide a variety of food and beverages and their carts come in a variety of shapes and sizes. A typical cart footprint is approximately 2' wide by 6'-6" long. If allowed along the future path, pavement markings or paving treatments can be used to demarcate where commercial activity is permitted. If allowed, spaces should be provided so that carts, vendors, and customer queues do not impede with the travel path of people walking and bicycling.

PATH FUNDAMENTALS

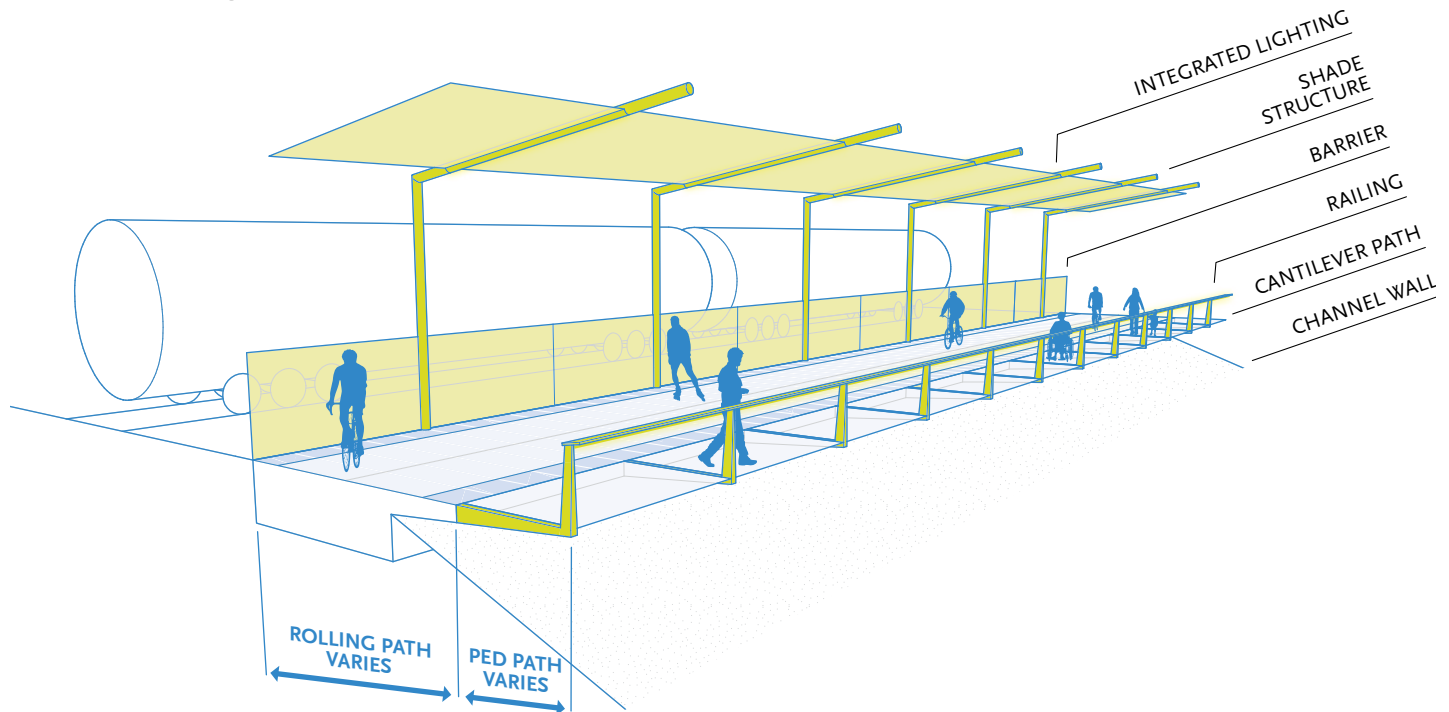

Overview

Path design elements are all of the individual design elements that come together to create a safe path that provides an outstanding user experience. Paths can provide a safe and outstanding user experience for people walking, bicycling, or connecting to transit. A facility that is physically separated from vehicle traffic appeals to a larger population. Paths should be well designed in relationship to their unique context and geography and provide a comfortable width responsive to anticipated user demand.

Design Features

PATH WIDTH

The recommended and minimum path widths are a function of user demand, path transitions, separation of modes, and other physical constraints. Path width is determined by the results of a demand analysis and Level of Service and Level

of Comfort Analyses (See Chapter 4 for Demand and LOS+LOC results for the LA River Path), as well as environmental and fiscal constraints. Path width considerations were determined for both separated and shared-use facilities.

Separated Paths

Examples of path cross sections where people walking and bicycling are physically separated from each other include:

- **High-demand:** 14 to 16 feet for bicycle/rolling path and 8 to 10 feet for pedestrian path. This cross-section may only occur at high demand access points.
- **Typical:** 12 to 14 feet for bicycle/rolling path and 6 to 8 feet for pedestrian path. Standard width bicycle and pedestrian pathway across most segments.
- **Constrained/low-demand:** 12 feet for bicycle/rolling and 4 feet for pedestrians. This configuration should only be applied in locations where typical widths cannot be accommodated due to physical constraints and/or user demand is low.

Although the path width will vary based on the feasibility of existing conditions and cost, the results of the Level of Service Analysis and other planning and design considerations provide that the ideal path cross-section is a 12 to 14-foot-wide bicycle path with an adjacent 6-foot pedestrian path in high demand areas. This represents the highest quality user experience to all modes where space and budget allow.

Shared-Use Paths

Where space is constrained and separated bicycle and pedestrian paths are not possible (per minimum dimensions for constrained widths) or in areas where expected demand is lower, a shared space or mixing space may be provided. Shared spaces may also be used in areas where a high degree of mixing is anticipated such as at path connectors, rest stops, and other pedestrian-oriented spaces where cross-traffic may be expected.

The existing path width for the Los Angeles Bicycle Path south of the project corridor is 14 feet. This 14-foot shared-use path is being considered for low-demand areas of the LA River Path. When possible, a 16-foot shared-use path would provide a higher quality user experience for path users.

TURNS

Path turns should be designed to minimize the likelihood of conflicts between users by providing for a wider radius curve. People

bicycling tend to lean when turning, and may cut corners or encroach on other paths of travel depending on these factors.

SIGHT DISTANCES

Appropriate sight distances provide an unrestricted view of upcoming potential conflict points (such as intersections or path crossings) in order for users to slow and come to a stop based on the speed of travel and distance to nearby crossings, mixing zones, or other path transitions. They are typically calculated according to the fastest design vehicles, e.g. electric bicycles and scooters, and take into account grades and curves.

OPERATIONS AND MAINTENANCE

Paths must be designed to facilitate ease of operations and maintenance. Wide path widths (greater than 10 feet) should be designed for segments of the path where maintenance vehicle access is necessary.

SPEED MANAGEMENT

Speed management strategies are necessary to mitigate potential conflicts between path users who may be traveling at different speeds. Strategies include the use of mixing zones, surface treatments, signage, etc.

Additional Resources

Proposed Public Rights of Way Accessibility Guidelines (PROWAG)

Advanced Notice of Proposed Rule Making (ANPRM) on Shared-use Path

USACE, 2014. Guidelines for Landscape Planting and Vegetation Management and Levees, Floodwalls, Embankment Dams, and Appurtenant Structures

PATH FUNDAMENTALS: CPTED

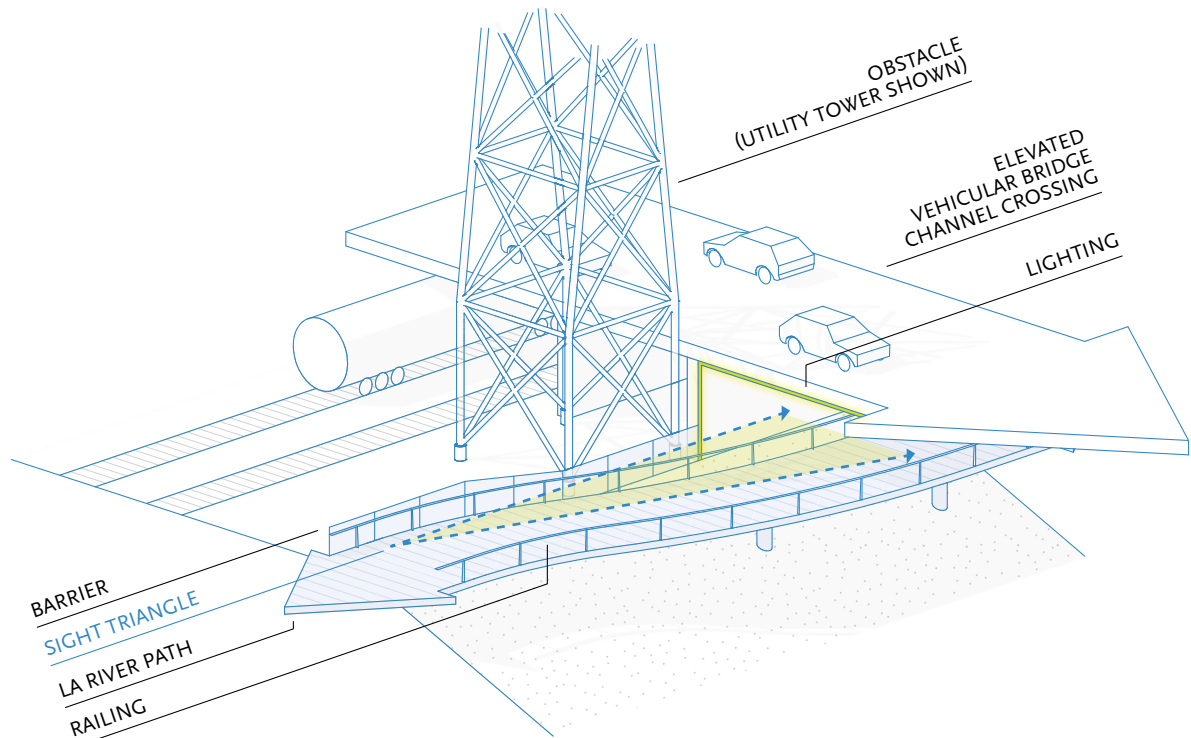

Overview

Crime Prevention Through Environmental Design (CPTED) is a design framework aimed at minimizing safety and security risk through design and maintenance strategies. Thoughtful design addresses both perceived safety issues (i.e. feeling safe or fear of crime) and actual safety threats (i.e. infrastructure failure and criminal acts). The basic premise of CPTED is that the arrangement and design of infrastructure and open spaces can encourage or discourage undesirable behavior and criminal activity. When all spaces have a defined use and the use is clearly legible in the landscape, it is easier to identify undesired behavior.

During outreach events, community members have expressed concern with personal safety on the path and expressed that it is one of the most important elements to address for a high-quality user experience.

Given the unique constraints of the Los Angeles River, the LA River Path will feature ramps, underpasses, bridges, and potentially isolated stretches of path. CPTED principles can be used to mitigate some of these challenges as well as concerns expressed by community members.

Design Features

There are four key CPTED design and maintenance principles¹:

- **Frequent access points** provide more route options and escape routes to path users and help to mitigate perceived safety concerns through legible wayfinding. This principle is of critical importance throughout the corridor in the spacing and design of access points.
- **Maximizing visibility** of the path increases the opportunity to see and be seen, and helps to keep all path users accountable. This principle will influence the location and design of underpasses, grade changes, and access points, as well as integration of the path with adjacent land uses.
- **Sense of ownership** over a space increases security. Design elements such as fences, paving materials, public art, signage, and landscape will help to convey a sense of place as well as municipal and community ownership over the LA River Path. This principle will influence the details and locations of design elements.
- **Maintenance** is an expression of ownership in a property. Regular maintenance of the LA River Path will communicate that the facility is cared for, while simultaneously contributing eyes on the corridor.

¹ CPTED Design Guidelines

PATH FUNDAMENTALS: TRANSITIONS

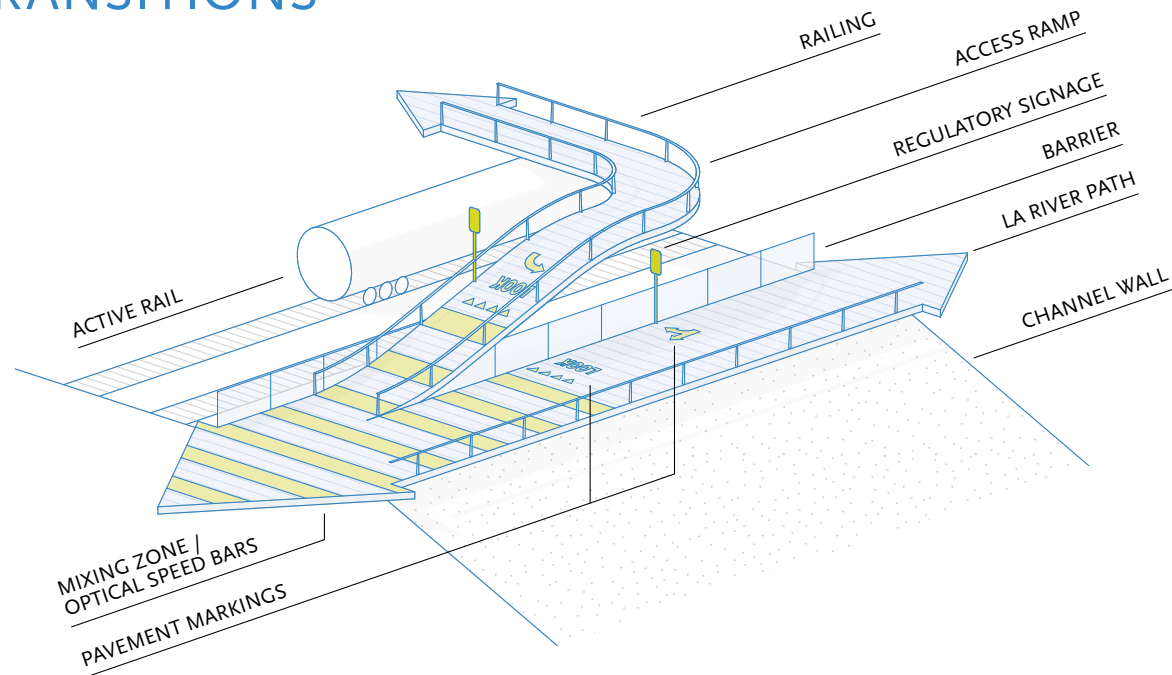

Overview

Path transitions along the LA River Path will occur where access ramps merge with the main path at access points. Transitions also occur where one path typology meets another, such as when an elevated path transitions into an at-grade path or where separated path segments transition into shared environments. Transitions may also include horizontal shifts to avoid physical obstacles such as utility towers or other structures.

Design Features

TYOLOGY TRANSITIONS

Design elements used to alert path users include pavement markings such as optical speed bars, zebra stripe crosswalks with shark's teeth, and "LOOK" wording and arrows. Signage may also be used, including warning and advisory signs. Physical treatments to alert path users include traffic calming measures such as vertical and horizontal deflection.

MIXING ZONES

Mixing zones are necessary where physical space constraints do not allow for separated modes, or at locations along the path where a high level of cross-traffic is expected. Mixing zones need to provide clear indication to all users that a transition is occurring in advance of the change, so that path users can adjust their speeds and awareness appropriately to proceed carefully into the mixing zone (see Path Fundamentals: Sight Distances).

Advanced warning can be accomplished with advisory signage, pavement markings, and the use of contrasting surface treatments (e.g. pavers/inlays with contrasting tones/textures, striping, or a combination of these treatments). These design elements help to guide path users safely through the mixing zone by alerting users to the change in conditions and thus reducing the speed differential.

PATH FUNDAMENTALS: SURFACE TREATMENTS

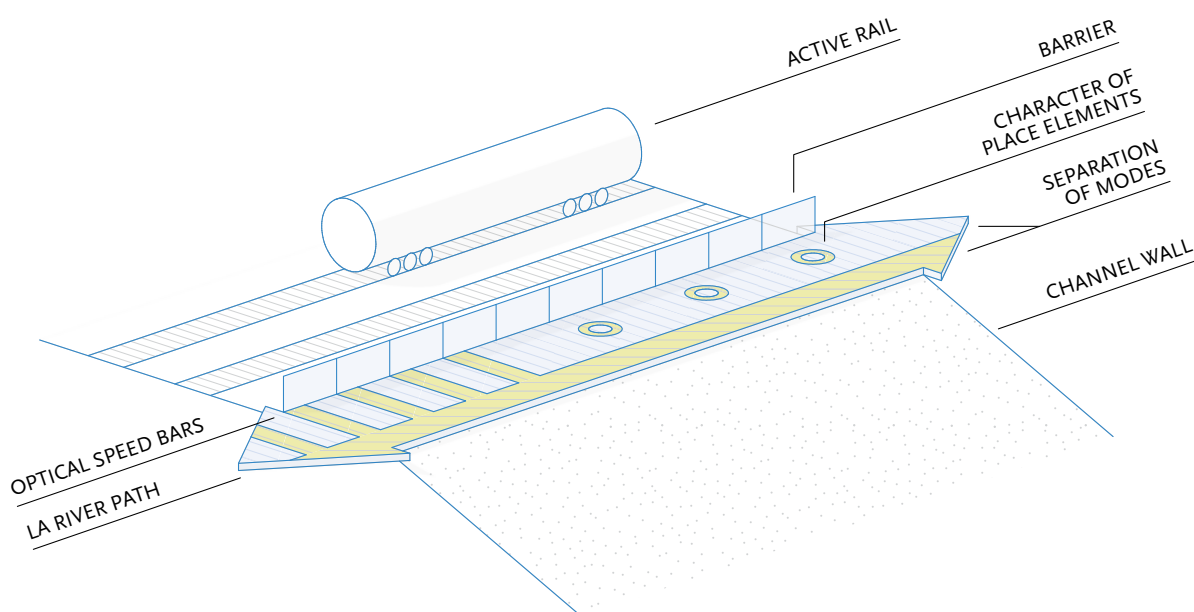

Overview

The surface of the LA River Path will provide a safe and accessible user experience, communicate regulatory and wayfinding cues, and contribute to the character of place for the entire project. Path surface treatments may vary in texture and/or tone depending on the location of the path, delineation of pedestrian and bicycle zones, tactile indications for mixing zones and other path transitions, and edge conditions. Path surfaces must meet or exceed ADA requirements for firmness, stability, and slip resistance. The path surface should be durable and withstand the physical elements while reinforcing design themes and user experience of the path.

Design Features

Surface treatments can be applied for a variety of purposes including^{1,2,3}:

- **Traffic Calming:** Indicating the need for faster travelers to slow or stop
- **Separation:** Path alignment, delineation of modes, and/or to restrict passing in constrained locations
- **Avoidance of Obstructions:** Indicate obstructions, such as trees, vendors, or others, along the corridor
- **Path Transitions and Mixing Zones:** Signal potential conflict points to path users
- **Wayfinding:** Minimize visual clutter of post-mounted signs, pavement treatments can be applied to serve as visual and/or tactile wayfinding
- **Character of Place:** Unifying and coherent design themes
- **Access Points:** Indicate location of access points and network connections

¹ NACTO: *Colored Pavement Material Guidance*

² FHWA *Interim Approval 14*

³ AASHTO *Guide for Development of Bicycle Facilities*

PATH FUNDAMENTALS: SLOPES AND GRADES

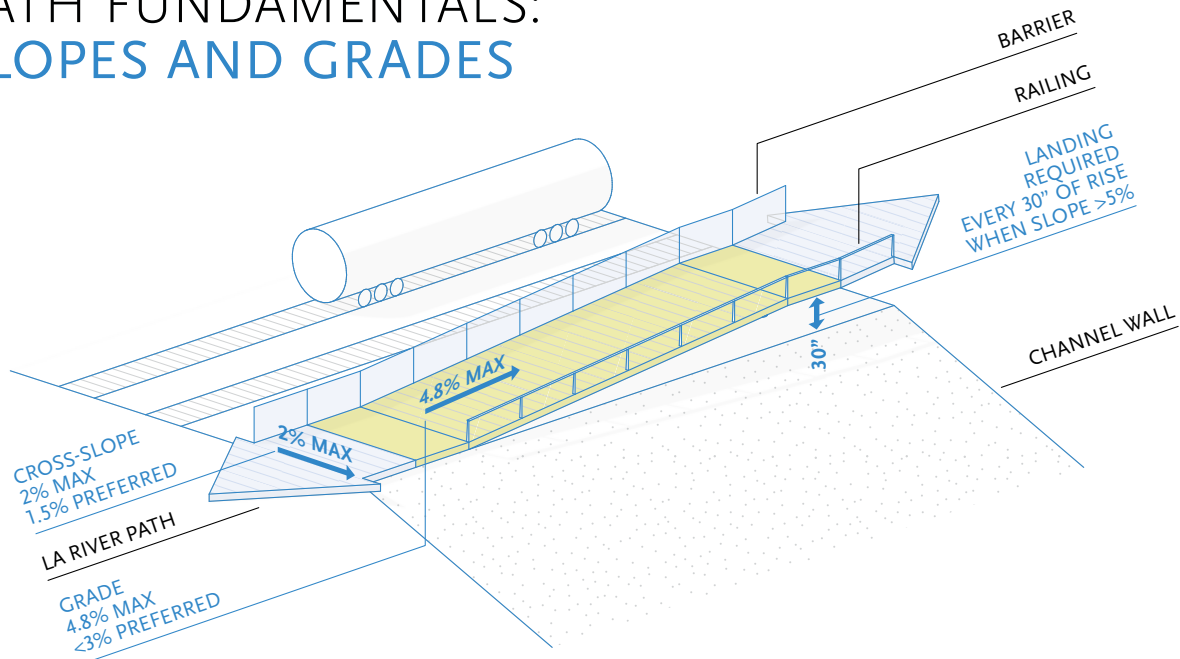

Overview

The LA River Path will feature extensive vertical transitions and ramping due to the existing conditions of the corridor. The most common occurrences will be to pass over/under an existing bridge or to ramp over adjacent rail lines to connect to an access point. Over the 8-mile corridor, there are 30 bridges that require navigating while most access points will require ramping approximately 24' over adjacent rail lines. At other locations it may be necessary to ramp up or down depending on the presence of physical obstacles, such as utility towers or existing structures. Vertical transitions are also necessary to satisfy minimum vertical clearance requirements for overcrossings and undercrossings.

Design Features

The complexity of ramp design and construction will vary depending on the grade

change, physical location of access points, the scale and orientation of path connectors, the proximity to competing structures (horizontal and vertical clearances), and budget.

Compact ramp designs feature both horizontal and vertical transitions to facilitate comfortable transitions in constrained spaces. These include U-, S-, or Z-shaped ramps and spiraled ramps.

SLOPE/GRADE

Running slopes under 5% are typically employed along pathways as they do not qualify as a ramp and therefore are not subject to the ramp requirements set forth by ADAAG. Slopes of 4.8% are generally employed to account for inconsistencies in the construction process and ensure slopes do not exceed 5%. For ramps, the Slope Bandwidth formula¹ can be used to evaluate the relationship between factors such as average slope, elevation

Figure 37. Slope Bandwidth

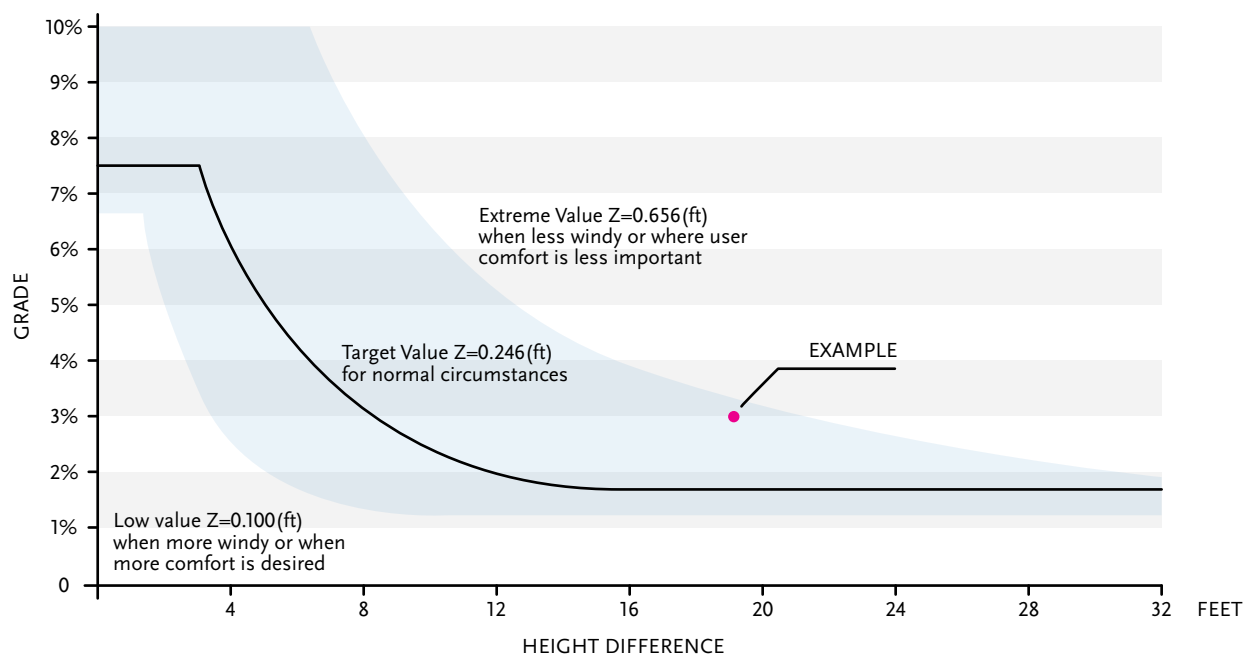

change, wind level, and user comfort. It is assumed that the longer and steeper a ramp, the more difficult path users will find it to traverse. A cross slope of 1.5% is preferred for drainage and accessibility, but may go up to 2% in constrained conditions.

However, the average slope of a ramp impacts user comfort significantly more than ramp length. The difficulty the user experiences while using a ramp can be calculated as the square of the average slope multiplied by its length, formulated as:

$$Z = (H/L)^2 \times L = H^2/L$$

or as the square of the height difference divided by its length, formulated as:

$$G = H/L = Z/H$$

where **H** = elevation change, **L** = length, **G** = average slope, **Z** = difficulty for users.

The Slope Bandwidth graph (see Figure 37) shows that target ramp slopes that are believed to be comfortable for the average person bicycling should be between 1.75% and 7.5%. The lower limit slope is between 1.25% and 6.67% and the upper limit maximum slope is 10%. The steeper the slope, the shorter the distance it may be employed to maintain the same relative level of ease or difficulty to the user.

¹ Dutch Design Manual for Bicycle and Pedestrian Bridges ipv Delft, 2015

Additional Resources

Caltrans HDM, 200, 300

UPRR and BNSF Guidelines for Railroad Grade Separation Projects, 4, 5

SCRRRA Grade Separation Guidelines, 7

PATH FUNDAMENTALS: EDGE CONDITIONS AND BARRIERS

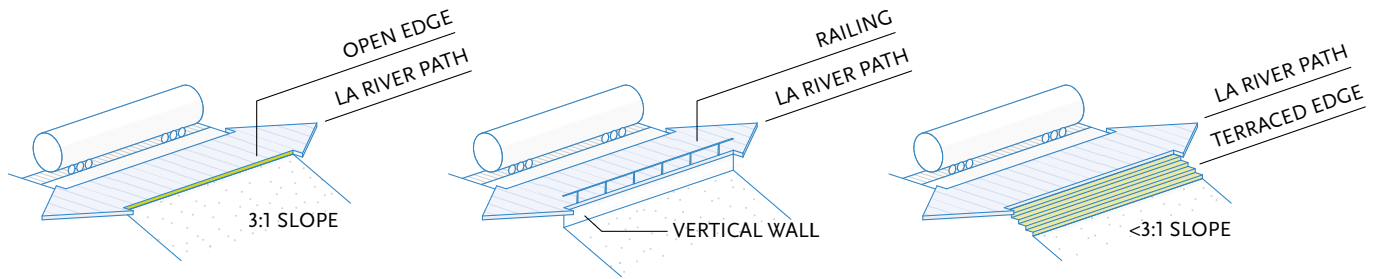

Overview

The LA River Path will traverse through a range of channel configurations, path types, and adjacent land uses. As a result, a toolkit of options is required in order to apply appropriate edge conditions to the unique circumstances along the path. Edge conditions comprise the range of treatments used to transition from the path of travel to space adjacent to the path. Edge conditions include shoulder buffers, screening, barriers, railing, and other visual and tactile cues to indicate the path of travel.¹ These treatments keep users from venturing off the path, protect users from hazards, delineate the path of travel where users are separated by direction, mode or speed, and enhance the comfort and attractiveness of the pathway.

Design Features

Shoulders should be a minimum of 2 feet wide (3 feet preferred) and constructed of the same material as the path or another durable surface.² Shoulders should be sloped at 2% to 5% away from the path to reduce ponding and minimize debris on the path.² Three feet minimum is required where signage or other furnishings will be installed.³

A shoulder of at least 1 foot should be provided between the path and any fencing or barrier. Where the shoulder serves as a pedestrian path, a maximum cross slope of 2% is required to remain compliant with ADA regulations.

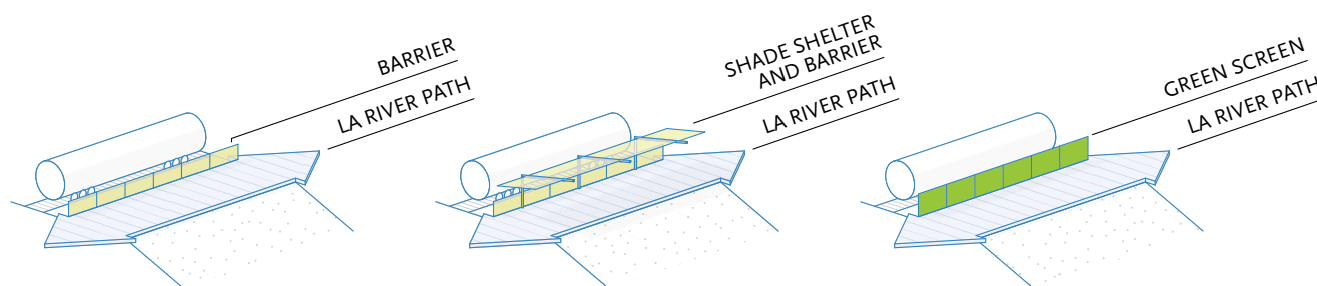

BARRIERS AND RAILINGS

Fences, walls, and railings will likely be a recurring element along the path to provide separation between the path and the channel edge, rail lines, and private property. In some areas, railings and/or security fences will be on both sides of the path. For overcrossing structures, barrier and fence types are prescribed by Caltrans (e.g. Type 26 and Type 732 barriers)². Previously Caltrans has granted exceptions to their standards which could apply to unique aesthetic treatments incorporated into this project.

A barrier or railing may be required along the river edge in locations where the channel wall slope poses a safety hazard. This could range from railings to curbs to a terraced edge. Portions of the existing path along the lower Los Angeles River within the county jurisdiction do not have barriers or railings along the river edge.

See Overcrossings design guidance on page 113 for more information on railings.

¹ UPRR and BNSF Guidelines for Railroad Grade Separation Projects, 4, 5

² Caltrans HDM, 1003.1

³ CA MUTCD

Additional Resources

USACE ETL 1110-2-571

SCRRRA Grade Separation Guidelines, 7

PATH SETBACKS: PATHS ADJACENT TO COMMUTER AND FREIGHT RAIL

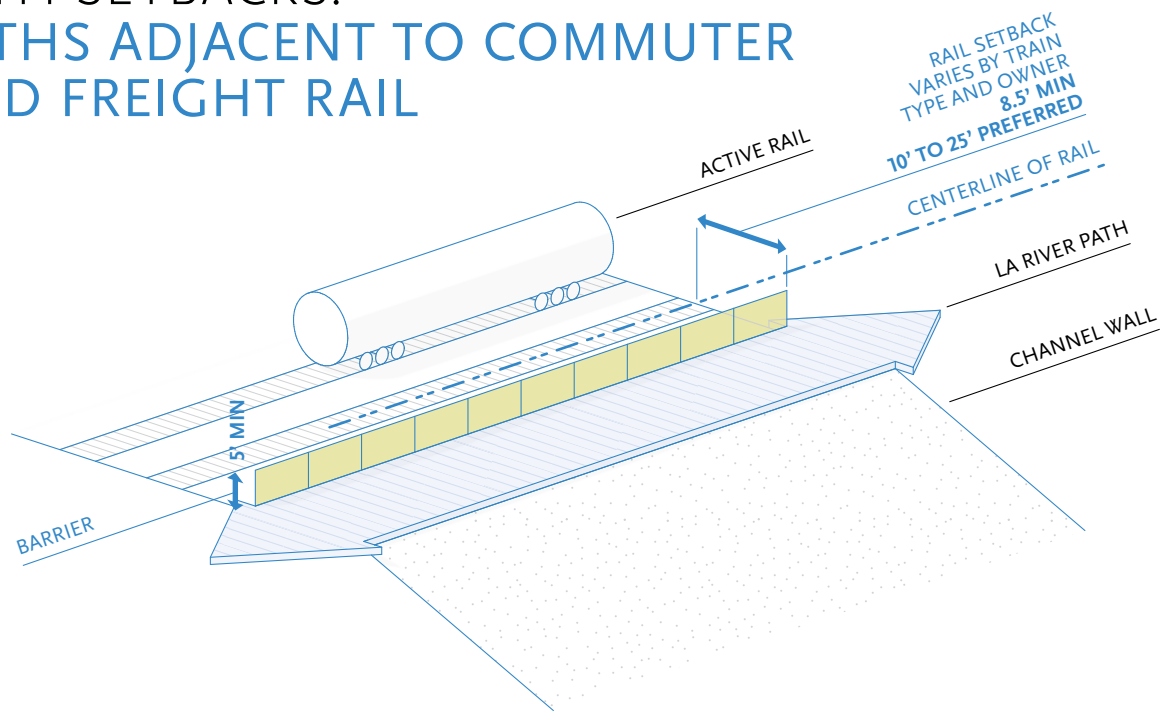

Overview

Because the path runs adjacent to both freight and commuter rail lines, it must adhere to minimum horizontal and vertical clearance requirements from the railway. This includes the path itself, as well as all adjacent structures, utilities, and screening. Development requirements should be cross-referenced between Metro, Burlington Northern and Santa Fe (BNSF) Railway Company, Union Pacific Railroad Company (UPRR), Southern California Regional Rail Authority (SCRRA) and the California Public Utilities Commission (CPUC), depending on the property owner or lessee.

Design Features

SETBACKS

“Setback” refers to the horizontal clearance between the centerline of the nearest track and the path. The LA River Path may be adjacent to freight or commuter rail corridors. There are different standards for appropriate setback distances based on train type (freight or commuter), speed, frequency, and length, and as a result setbacks will vary.

For the LA River Path, the preferred setback range from adjacent rail corridors is between 10’ and 25’. At a minimum, the setback must be greater than 8.5 feet to accommodate buffer or physical separation space, while a minimum 10-foot setback is preferred where space allows.¹ Depending on the rail operator and the site conditions, agencies may require a setback of up to 25’ in select locations.

Additionally, paths are required to maintain a minimum 10-foot setback from the centerline of the nearest freight track by CPUC.² Along a curved track segment, all specified side clearances are an additional one foot wider to accommodate vehicle sway.

Metro requires that building accessories and landscaping be a minimum distance of 10 feet from the overhead catenary system and support structures.³

In addition to appropriate setback, high-security fencing to separate and discourage trespassing should be provided. Whenever feasible, transparent fencing, public art and landscaping can create a more comfortable user experience. Public art and landscaping may also be used to create a more comfortable user experience.

¹ FHWA *Rails with Trails Lessons Learned*

² CPUC GO 26-D

³ *Metro Adjacent Development Handbook*

Additional Resources

California Public Utilities Commission General Standards

USACE ETL 1110-2-571

PATH CROSSINGS: OVERCROSSINGS

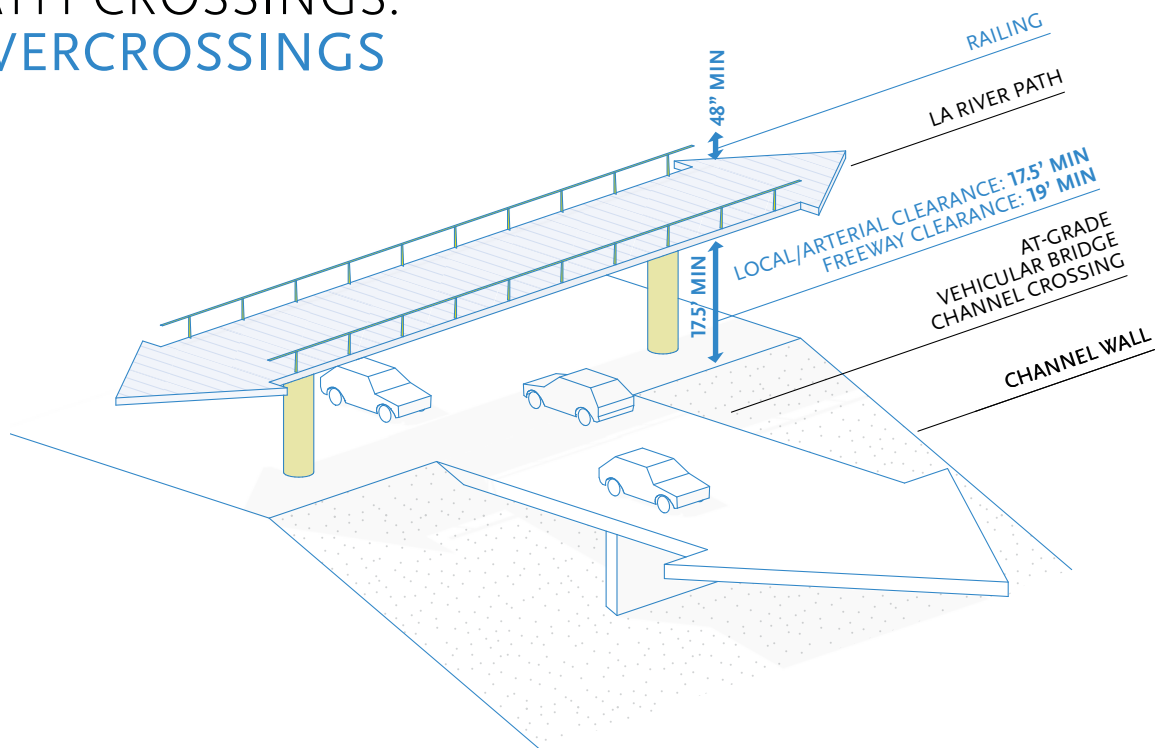

Overview

The LA River Path will need to pass over a number of existing bridges, including major roadways such as Main Street and Washington Boulevard. Path overcrossings provide grade-separated path crossings over barriers such as busy roads, railways, and the river channel. An overcrossing is needed when there is no other logical crossing, such as an underpass or at-grade crossing. LA River Path overcrossings make the path more visible to pedestrians and drivers on roadways, and may help to attract new users.

The primary design standards for bicycle bridges and tunnels in California are Caltrans HDM 208, Caltrans Bridge Design Specifications, and AASHTO Guide Specifications for Design of Pedestrian Bridges (December 2009). HDM 1000 and the AASHTO GDBF provide additional guidance. For bridges that cross over active railroad tracks, guidance from UPRR, BNSF, and SCRRRA becomes relevant.

Design Features

- Overcrossings should have a minimum width of 8 feet.¹ Ideally, when the core path passes over a road or railway, it would maintain the width of the adjoining path. Additional width should be provided at scenic viewpoints or other path pull-outs.
- Railing height shall be between 48 inches and 54 inches above the top of the riding surface.²
- A centerline stripe is recommended for grade separated facilities.³

CLEARANCE OVER ROADWAYS

The minimum required clearance is 17 feet 6 inches over local roads and arterials, and 19 feet over freeways and expressways.³

CLEARANCE OVER ACTIVE RAIL (UPRR, BNSF AND SCRRRA)

In addition to rail bridges that require overcrossings, most of the LA River Path's many access points will require the path to pass over the adjacent rail lines in

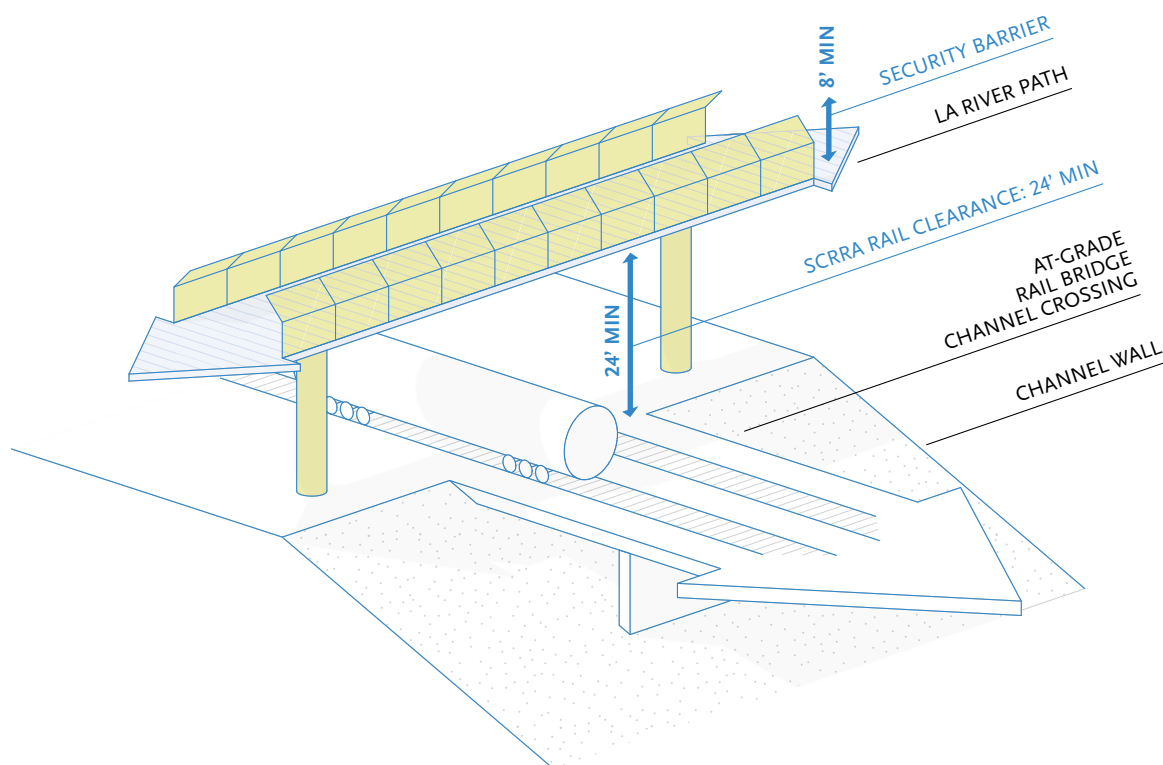

order to connect to the on-street bicycle network. Although UPRR and BNSF allow a minimum clearance over rail lines of 23 feet 4 inches⁴ and 23 feet 6 inches,⁵ SCRRRA requires 24 feet.⁶ SCRRRA allows temporary vertical clearance (i.e. during construction) to be reduced to 22 feet.⁶

Clearances will impact both the height of the path and the spacing of structural posts. Minimum horizontal clearance, measured from the centerline of the nearest railroad track to the obstruction or structure, varies based on the presence or absence of crash walls/barriers and their height.

- In the absence of a crash wall, 25 feet minimum horizontal clearance is required.⁵
- UPRR and BNSF allow horizontal clearance to be reduced to 12 feet or less if an appropriately sized crash wall is provided^{4,5}, although SCRRRA sets a 15-foot minimum clearance.⁶

- Bridge abutments and piers must normally be located outside of the railroad right-of-way.⁷
- Bridges parallel to existing or proposed railroad structures shall have a clear horizontal separation of no less than 25 feet, and bridges perpendicular to railroad structures shall have a horizontal clear separation of no less than 200 feet from the nearest railroad structure abutment.⁷
- For pathways over UPRR tracks, the total height of fencing and barrier must be a minimum of 8 feet high.⁴

¹ AASHTO *Guide for Development of Bicycle Facilities*

² CA LRFD 13.9.2

³ Los Angeles County GG

⁴ Union Pacific Railroad standards

⁵ BNSF Railway standards

⁶ SCRRRA standards

⁷ AASHTO LRFD *Bridge Design Specifications*

Additional Resources

CPUC GO 26-D

AASHTO *Guide Specifications for Design of Pedestrian Bridges*

This page intentionally left blank

PATH CROSSINGS: THROUGH STRUCTURES

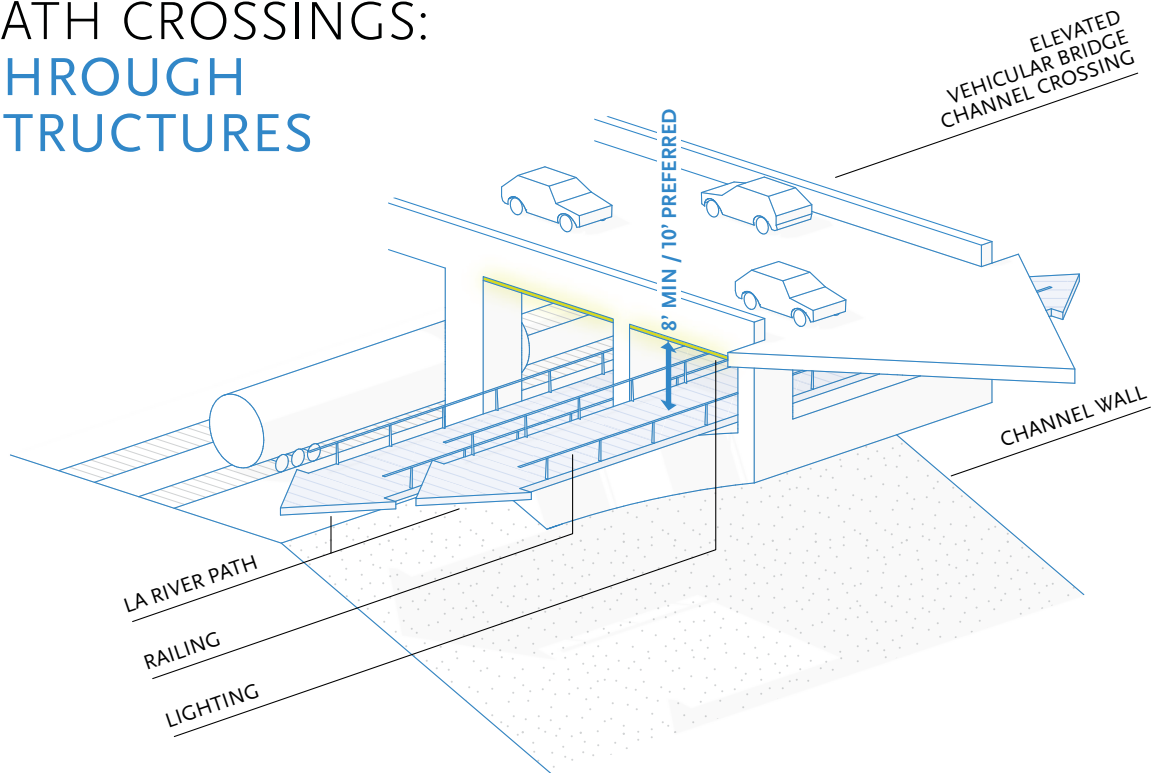

Overview

Where the LA River Path must interact with existing bridges, it may be desirable to construct the path through the bridge structures. Depending on the width and height of the openings on the bridge, the path may need to be narrowed, separated, and/or ramp up/down to pass through the existing bridge structure. Bridges where this may be feasible include Spring Street, Cesar Chavez Avenue, and 4th Street.

Design Features

If a grade change is necessary to bring the path up to same level as the openings in the bridge, the ramping must conform to running slope standards per ADAAG.

Separation of modes is recommended in this space to account for speed differentials and constrained physical space. If not possible, a shared space with visual and tactile indications should be used to alert various path users of the transition.

Lighting will be necessary to mitigate safety concerns and maintain visibility, and may be used to highlight and complement the existing bridge architecture.

PATH CROSSINGS: UNDERCROSSINGS

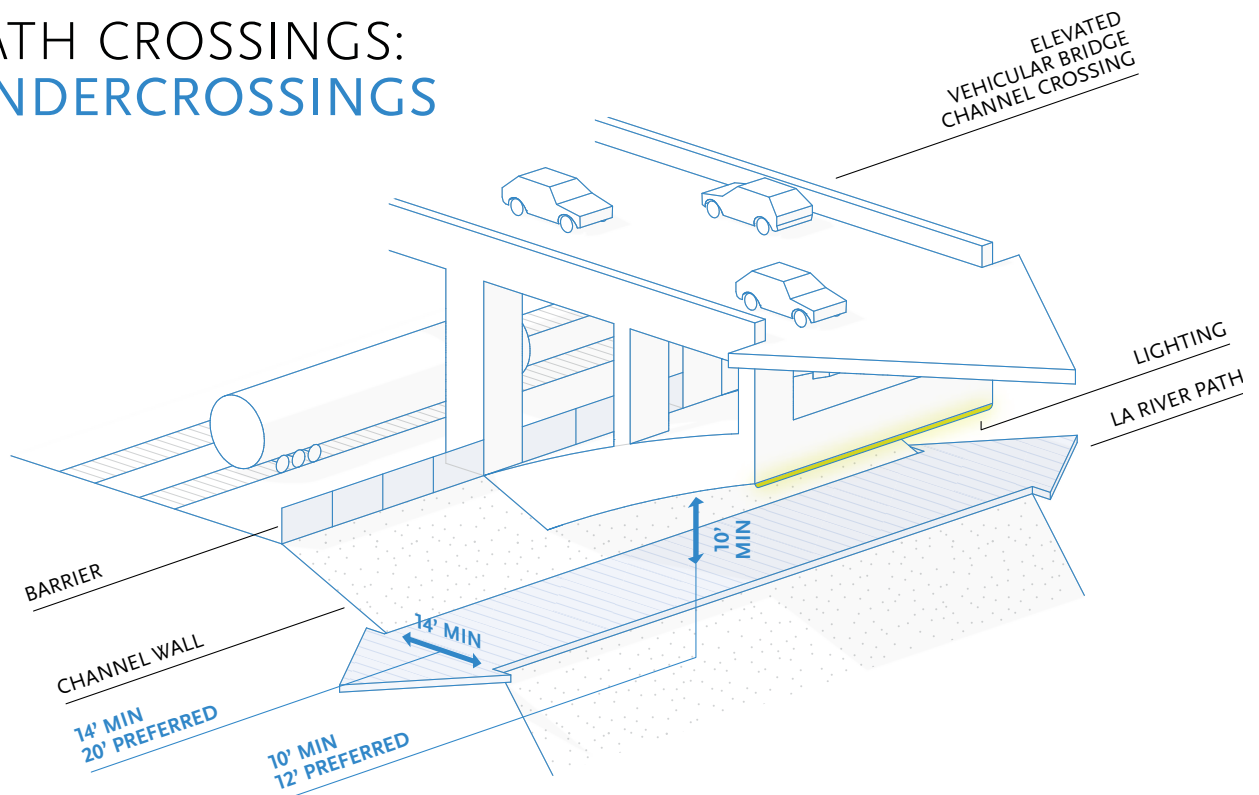

Overview

The LA River Path will require grade-separated undercrossings at a number of existing rail and vehicular bridges. The conditions of each undercrossing are unique to the bridge architecture, channel configuration, and whether or not the bridge is at-grade or elevated. Example locations where undercrossings may be used include Broadway, 1st Street, and Downey Road. These locations provide grade-separated crossings.

PATH UNDERCROSSINGS

A minimum vertical clearance of 10 feet shall be provided for pedestrian undercrossings with 12 feet preferred.²

Minimum horizontal clearance for a path undercrossing should be 14 feet wide.¹ Ideally, the width of the undercrossing should match the width of the adjoining path. These minimum clearance height and width dimensions also allow access for maintenance vehicles.

The CPUC requires any road serving vehicular traffic which crosses under a rail line to provide a 15-foot clearance above the surface of the road;² however, the final clearance requirement is decided based on input from the CPUC and rail company, and may be less (10 to 12 feet) for underpasses accommodating people walking and bicycling only.

ILLUMINATION

All-day illumination (24/7) should be provided along the entire length of the undercrossing. The appropriate level of illumination will vary by location, but 5 lux to 22 lux is generally considered an appropriate average maintained horizontal illumination level.³ Higher illumination levels should be considered along longer undercrossing segments, or in places where security issues have been identified. Light poles should be human-scaled and luminaires and poles must meet horizontal and vertical clearance requirements.

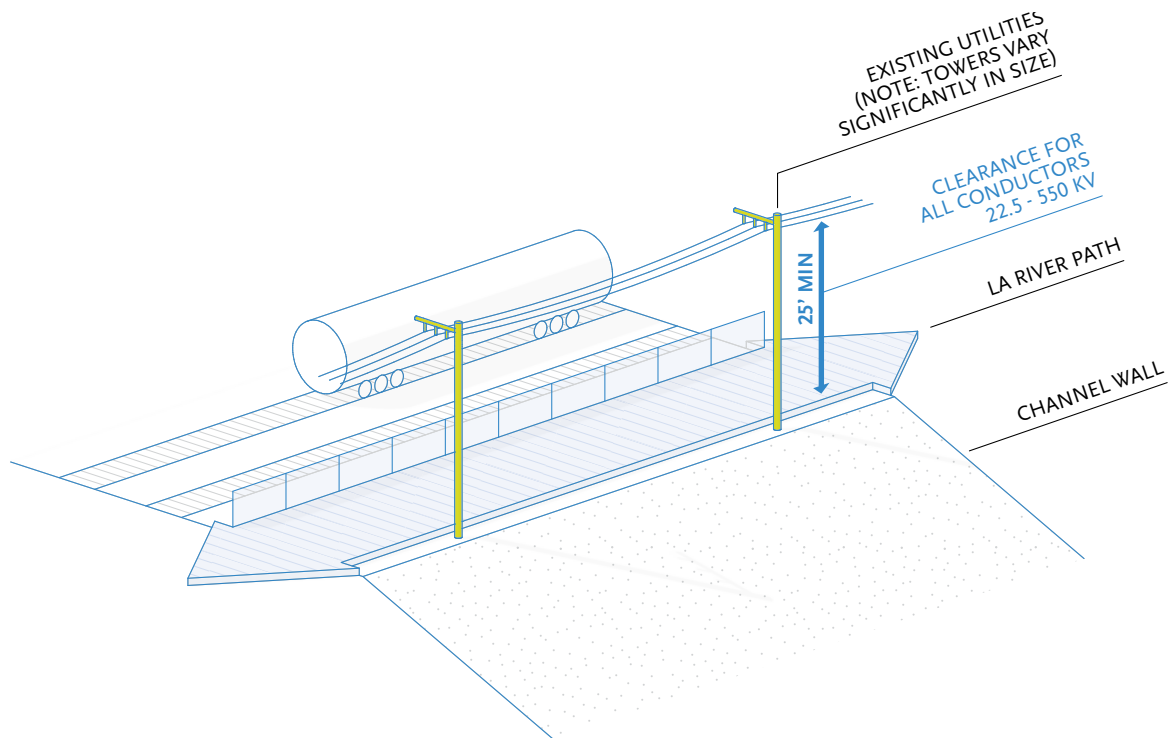

OVERHEAD TRANSMISSION LINES

The CPUC provides design standards that govern development near overhead electrical construction, which include minimal clearances of wires, cables and conductors. These minimum values depend on the location and voltage of the conductors in question. The minimum horizontal clearance ranges from 6 feet (for a 22.5 kV–300 kV conductor) to 15 feet (300–550 kV);⁴ however, precedent on other parts of the river has the pathway going through/under these lines. The minimum vertical clearance from all conductors ranging 22.5–550 kV in voltage is 25 feet above ground.⁴

¹ City of Los Angeles GG

² CPUC general

³ Caltrans HCM 1003.1

⁴ CPUC GO 95

PATH CROSSINGS: AT-GRADE CROSSINGS

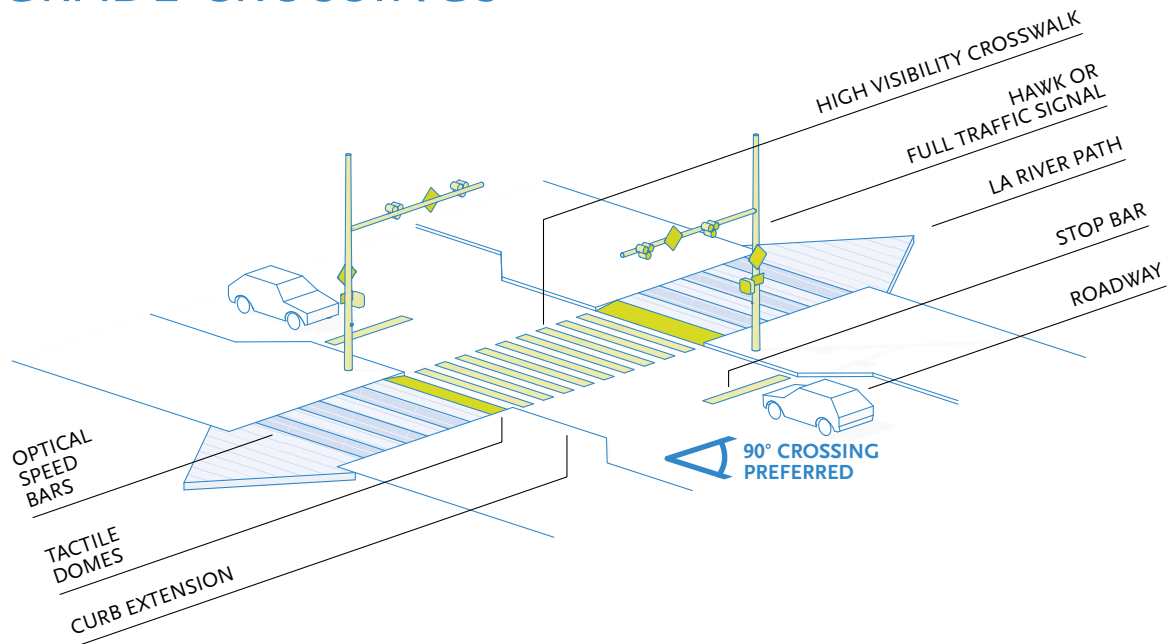

Overview

At-grade crossings will be limited to a few key locations on the LA River Path. While grade-separated overcrossings and undercrossings will be used along the core path alignment, at-grade crossings may be considered for select access points where roadway or rail line volumes are low. If utilized, at-grade crossings will be designed to be safe and comfortable and will be accessible by path users of all ages and abilities. Improvements at existing on-street crossing locations may include median refuge islands, Rectangular Rapid Flashing Beacons (RRFB), and Pedestrian Hybrid Beacons (HAWK).

Design Features for At-Grade Railroad Crossings

At-grade rail crossings are regulated by the California Public Utilities Commission (CPUC). The design and construction of all new path railroad crossings must be approved by CPUC. Necessary railroad protection and specific design standards are determined based on a joint field review involving the railroad company (BNSF or UPRR, and Amtrak) and the CPUC. If the proposed path passes through any existing at-grade rail crossings, the crossing would need to be upgraded to the current standard.¹

At-grade railroad crossings must be at least as wide as the traveled way of the facility, ideally straight and at right angles to the rails. A number of modifications, special construction techniques, and materials are available to accommodate challenging site conditions and geometries.²

Design Features for At-Grade Street Crossings

At-grade crossings at signalized street intersections can be addressed by routing path users to the intersection. Appropriate crossing treatments will depend on a range of variables including crossing width, number of lanes, presence of median, and roadway speed and volume. Applicable treatments may include full signalization, the use of a Hybrid Beacon, or RRFBs. Both devices are Caltrans- and FHWA-approved devices that may be considered at locations where no traffic signal currently exists. These devices would be paired with high visibility marked crosswalks, appropriate signage, and other possible crossing enhancements such as curb extensions and median refuge islands to reduce the roadway crossing distance.

Definitions:

Pedestrian Hybrid Beacon (PHB or HAWK): a traffic control device used to stop road traffic and allow pedestrians or bicyclists to cross safely, while stopping road traffic only as needed.

Rectangular Rapid Flashing Beacon (RRFB): a user activated flashing light that is used at marked crossings to increase visibility of the crossing location.

¹ CPUC GO 26-D

² Caltrans HDM 1003.1

Additional Resources

AASHTO *Guide for Development of Bicycle Facilities*

AASHTO *Guide for the Planning, Design and Operation of Pedestrian Facilities*

PATH ELEMENTS

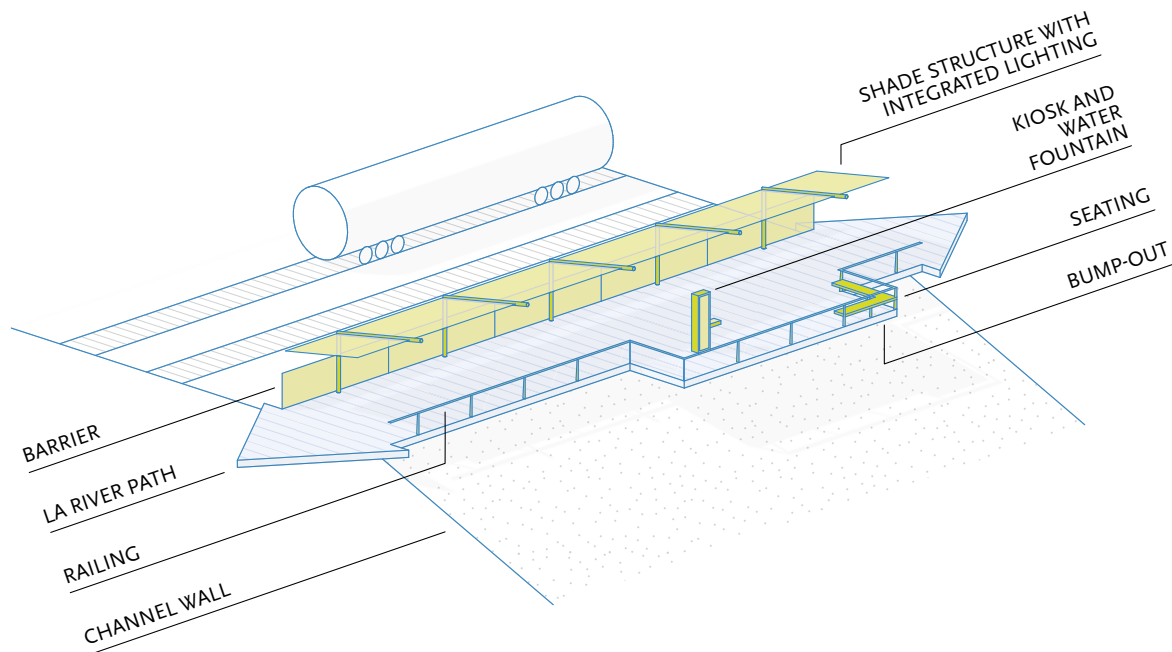

Overview

Path elements are important design features that improve safety and security for path users, enhance the attractiveness, comfort, and enjoyment of the path as a transportation and recreational corridor, and contribute to the path as a destination in and of itself. Path elements are important on the path itself and at key access points. They also directly respond to the desires of the community; community feedback indicated a strong desire for amenities including shade, lighting, art, and landscape.

Design Features

Elements may include:

- Lighting
- Seating
- Drinking fountains
- Restroom facilities
- Public art
- Landscaping/vegetation
- Informational/educational/wayfinding signage
- Bicycle fix-it stations
- Shade structures

Additional Resources

CPTED

AASHTO Guide for Development of Bicycle Facilities

PATH ELEMENTS: PATHWAY INNOVATIONS

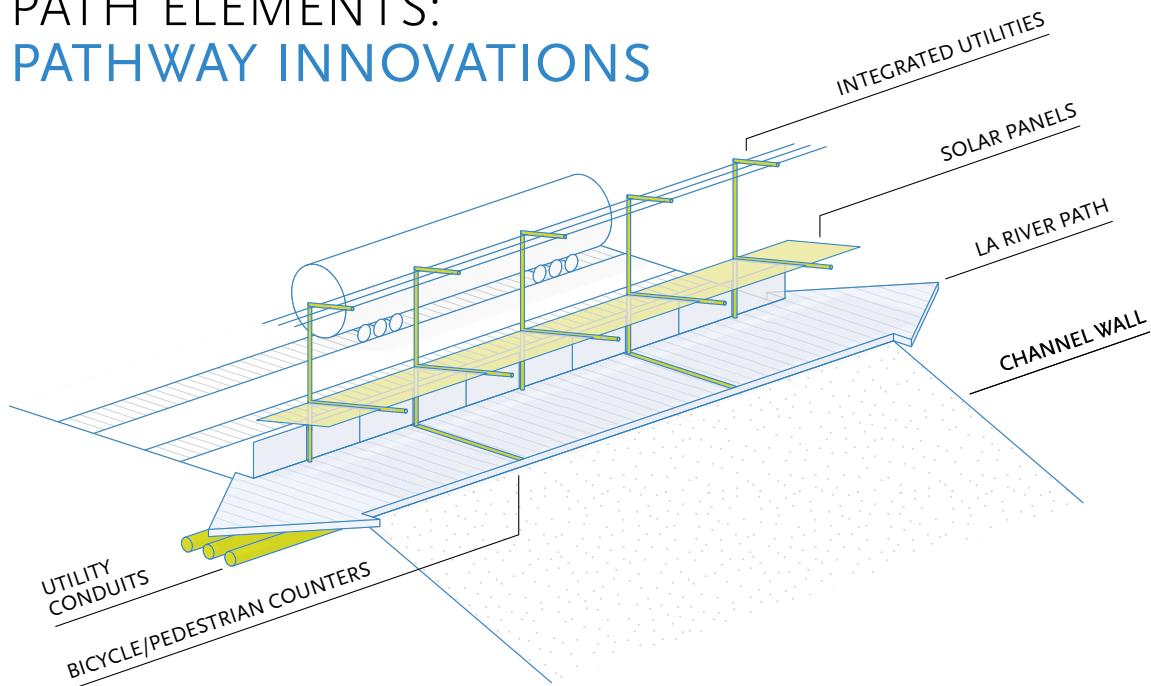

Overview

Innovative design features and technologies may be incorporated throughout the path, to enhance the user experience along the path, encourage/discourage user behavior, collect data about path use, and integrate other utilities and technologies. The path should be designed to allow for future technological upgrades.

Design Features

Potential design features that may be considered include:

- Bicycle and pedestrian counters
- Wi-Fi hot spots
- Bluetooth sensors and transmitters for count technologies
- Smart phone technology/apps; project website integration
- Shade structures
- Solar panel arrays
- Charging stations for e-bicycles, scooters or other personal mobility devices, as well as phones and other personal gadgets
- Educational/interpretive signage and visualizations
- Utilities/Irrigation/Data transmission integration
- Power lines
- Communications, fiber optic lines
- Irrigation/sewer lines

PATH ELEMENTS: WAYFINDING

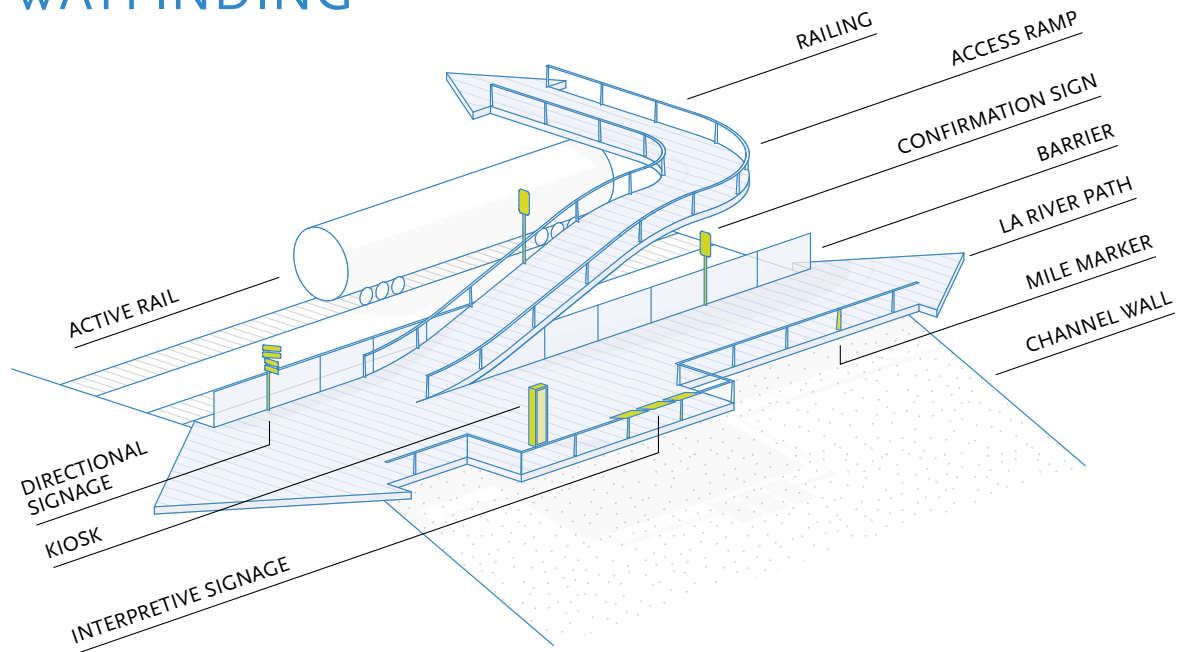

Overview

A comprehensive wayfinding system increases user comfort and accessibility to the path. The complete family of wayfinding elements should comply with relevant regulations and coordinate with existing LA River Path wayfinding while also advancing the project's design aesthetic and lending character of place to the project.

Design Features

Wayfinding signs located throughout the corridor should indicate to path users:

- Location of destinations
- Directions and distances
- Mileage in quarter-mile intervals

Signage can serve both wayfinding and safety purposes including:

- Helping to familiarize users with the path corridor and network

- Helping users identify the best routes to destinations
- Helping to address misconceptions about time and distance
- Helping emergency responders pinpoint exact locations

Sign Types

Signage elements are used to guide people through districts and to local landmarks and destinations. These elements are designed at a human scale and include directional signs, information kiosks, and map panels. The Spectrum of Signs (see Figure 38) represents a non-exhaustive range of elements that may be included in a path wayfinding family.

Path users rely on landmarks, edge treatments, and visual and tactile cues to orient themselves along the path. Wayfinding signage and pavement markings provide path users with clear, concise information about where they are in relation to other

Figure 38. Spectrum of Signs

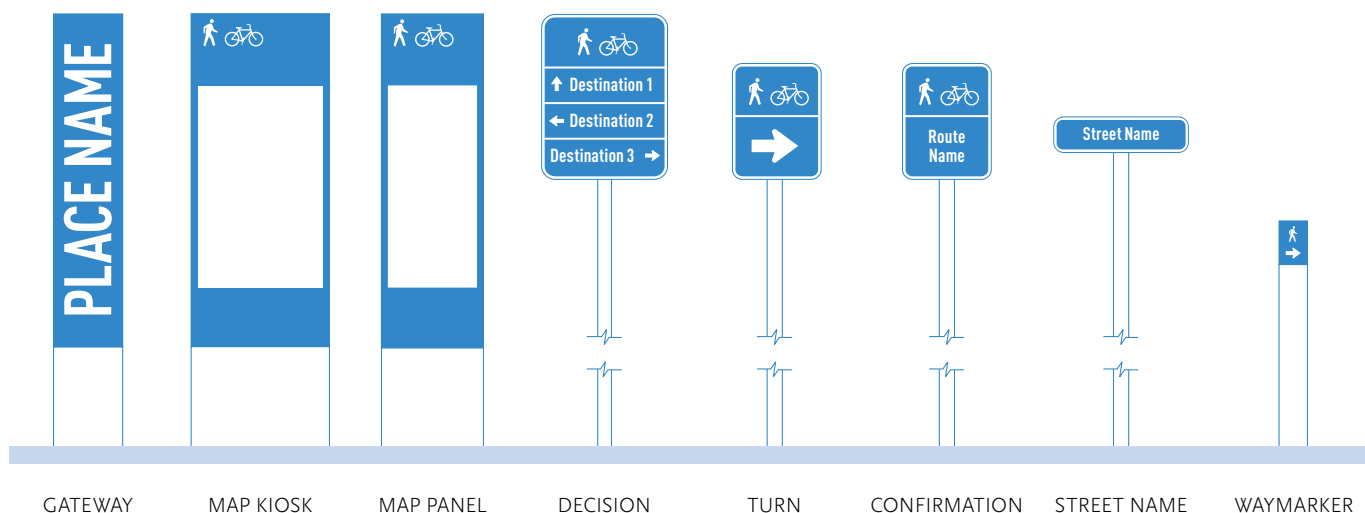

destinations, and the larger path and street network. This information is necessary for accessibility, comfort, travel distance and time estimation, and confirmation that path users are where they want to be (and/or are heading in the right direction).

The family of wayfinding elements will be specific to the LA River Path, align with existing Los Angeles River wayfinding elements, contribute to the overall path identity and character, and conform to applicable standards and best practice.

Wayfinding signs also visually cue motorists and fast moving bicyclists that they are arriving at the entrance of a path and should use caution. Signs are typically placed at key locations leading to and along path routes, including route intersections. Pavement markings work well for mile markers and street names in addition to bicycle and pedestrian symbols with directional arrows.

The CPUC GO 90 requires minimum clearances of electric wires from signs; these requirements vary based on the nature of the sign (location, illumination, etc).

Multi-sided kiosks provide opportunities to highlight local businesses, community partners, or advertisements. Paid advertisements may provide a revenue source for path maintenance and operations.

Additional Resources

LA River Path Feasibility Study

CPUC GO 90

Metro Signage Standards

CHANNEL OPERATIONS

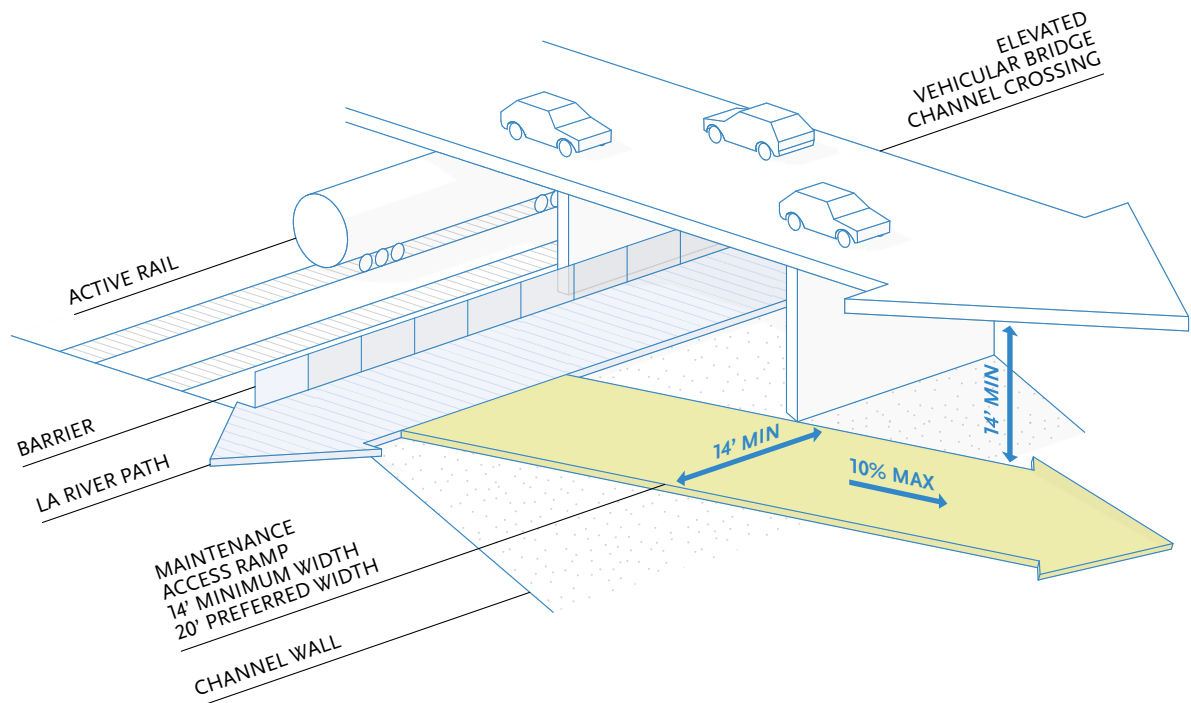

Flood Control Operations and Maintenance

USACE Operation and Maintenance requirements and priorities are described in the USACE Operation, Maintenance, Repair, Replacement, and Rehabilitation (OMRRR) Manual, Los Angeles County Drainage Area (LACDA), December 1999 (LADM No. 1130-2-13). Other relevant documents include ER 1130-2-304, which includes information on the policies and procedures applicable to civil works projects for which operation and maintenance is a responsibility of USACE, and ER 1150-2-301, which contains information applicable to projects for which operation and maintenance is a responsibility of local interests.

USACE understands “operations” of the Los Angeles River channel to include the following elements:

- **Flood Operation:** In accordance with federal flood control regulations
- **Mobilization:** Response in times of flood emergency
- **Coordination:** Between operating agency and local organizations during flood periods
- **Inspection:** Patrolling during periods of storm runoff to detect vulnerabilities
- **Multi-Purpose:** Conservation, habitat, water quality, recreation, and development

USACE understands “maintenance” to include the following elements:

- **Inspection:** To ensure flood control facilities are maintained and functioning
- **Training:** Program implementation and personnel training
- **Public Interest:** Police protection, public health and safety

Access and Clearance Requirements

Typical flood control requirements address horizontal and vertical clearance, maximum slopes for access ramps, and vehicle loading. The following general provisions¹ apply except when more specific guidance is provided by USACE or LACFCD:

- Vehicle maintenance ramps extending down into the channel should be a minimum of 14 feet wide, 20 feet preferred
- 14 feet overhead vertical clearance above the path width shall be maintained for maintenance vehicles and equipment
- At locations where large, heavy maintenance vehicles require access, H₂O loading should be provided
- Maintenance access ramps should not exceed a 10% maximum slope

General Design Considerations

For areas approved for landscaping, a minimum clearance of 8 vertical feet and up to 15 horizontal feet beyond the toe of the levee must be provided to ensure that the safety, structural integrity, and functionality of the stormwater channel are retained and that accessibility for maintenance, inspection, monitoring, and flood fighting are not compromised.²

Flood control agencies currently managing the channel generally need a minimum 14-foot ramp into the channel. Where feasible, a paved maintenance road could be provided at the top of the levee for maintenance access. The LA River Path may serve a dual purpose and help provide some maintenance access.

For facilities such as the Los Angeles River where urban development surrounds the channel, USACE prioritizes aesthetic treatments and maintenance that “maintain or improve upon the original design concept level of aesthetic quality and utilitarian effectiveness.”³

Where appropriate, USACE encourages paving enhancements such as ornamental grouted stone, stamped concrete, and paver blocks.³

Block-letter channel station numbers must be visible from the bottom of the channel, access ramps, or berm roadways to identify locations for inspections or maintenance work.³

¹ City of Los Angeles GG

² ETL 1110-2-571

³ USACE 1999, V-iii

ELEVATORS

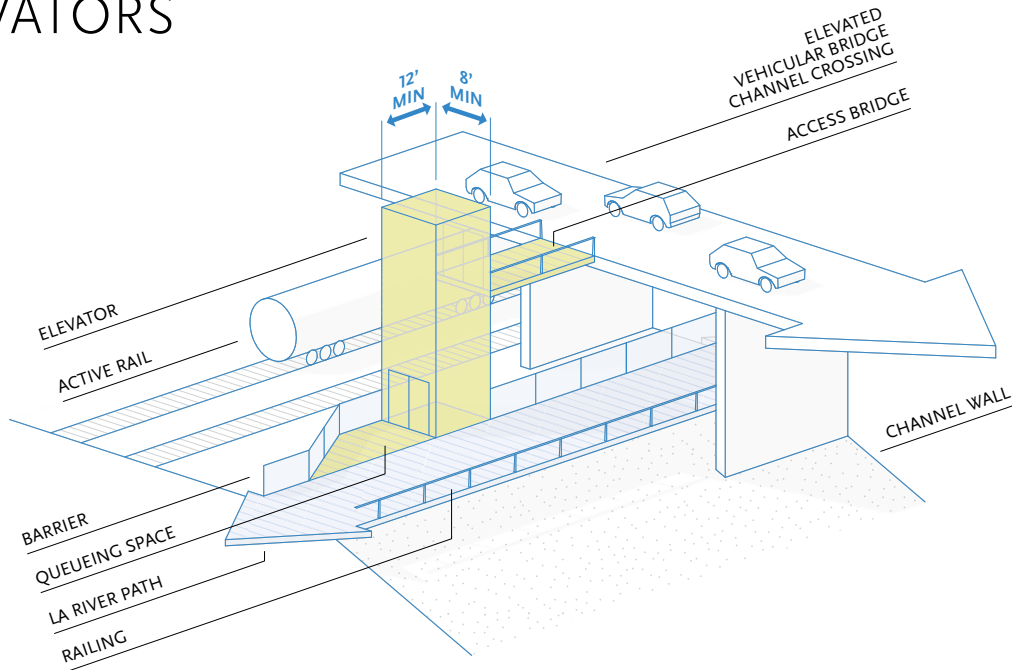

Overview

Access to the LA River Path is challenging due to existing railways. Most access will be achieved by ramping over adjacent rail lines, but in select conditions, such as providing access to an elevated historic bridge, elevators may be considered as an alternative to ramps. While stairs and ramps will also be provided, elevators can provide a better option for ADA and users of all ages and abilities. Elevators may serve other purposes besides their typical function, such as serving as a landmark architectural feature to path users. Elevators may also function as a structural element for the path. They would also require additional maintenance considerations.

Preferred Elevator Design

If utilized, elevators that may serve the LA River Path should be functional for all path users, including people with bicycles. A larger cab with minimum dimensions of 8' wide by 12' deep with 4' wide doors is preferred to accommodate multiple bicycles and bicycle types, as is an elevator that allows for users to enter one door and exit through a door on the opposite side.

If used for the LA River Path, path elevator locations may provide an opportunity to integrate path elements, such as wayfinding, art, and shade.



LAFAYETTE BRIDGE, PORTLAND

The Lafayette Bridge provides safe access to the TriMet Orange Line in Portland's Brooklyn neighborhood. The 185'-span weathered steel truss bridge crosses over three Union Pacific train lines and has bicycle elevators on both ends connected by a 12' wide walkway. Stairs provide alternate routes and small plazas with lighting, public art, landscaping, and adequate queuing areas bookend the connecting streets.

67. Lafayette Pedestrian Bridge, Portland, OR

68. Pedestrian Connexion Media Luna, Pamplona, Spain

69. Lafayette Pedestrian Bridge, Portland, OR



PAMPLONA, SPAIN

The system consists of an electric panoramic elevator with a capacity for 22 people. The interior of the cabin measures 5.5 ft x 6.5 ft. The upper and lower boardings provide two canopies that protect users from the elements, when accessing the elevator. The elevator tower is constructed of diaphragm walls and corten steel box girders. The lower boarding space is situated next to a sloping hill, allowing for a wide access. The lower boarding area is covered by a glass canopy and framed by concrete walls coated by corten steel, matching the same materials used for the tower.

FACILITY TYPOLOGIES

Overview

There is not a one-size-fits-all solution for the LA River Path. Within the corridor, there are varying conditions in channel shape, adjacency of rail lines, utilities, bridges, and land uses. To simplify the approach to designing a path within this context, the project team created a series of path typologies to respond to unique conditions. These typologies describe generalized design solutions to placing the path within the complex corridor. The various facility typologies can be combined in many ways to create one path.

The design of the LA River Path will consist of a variety of structural and non-structural path options, transitioning seamlessly between path typologies over the full eight miles of the project corridor. Conventional structures may be considered throughout the project corridor where existing conditions prevent non-structural options, such as a path on the top of the bank (at-grade) or cut into the channel (incised), from being used.

Path types are detailed in the following pages. Each path type consists of a number of opportunities and constraints that guide how the amenities desired by community members, such as lighting, shade structures, and landscaping, can be incorporated into the path. See Chapter 3 for more information on community feedback on vision and goals for the path, and Chapters 7 and 8 for more information on path amenities.

These path types and their trade-offs were presented to the community during January and February 2019. Community feedback on path types and their trade-offs is detailed in Chapter 9.

Path Types

- Elevated
- Top-of-Bank/Cantilevered
- Incised
- Bottom-of-Channel

Traversing Utility Towers

- Under
- Around
- Through

Traversing Existing Bridges

- Over
- Under
- Through

Structures

- Conventional
- Custom

Photos, opposite:

70. Trapezoid channel with adjacent rail

71. Trapezoid channel beneath bridge

72. Trapezoid channel with adjacent rail and utilities

73. Box Channel

74. Bridge connection to street



70



71



72



73

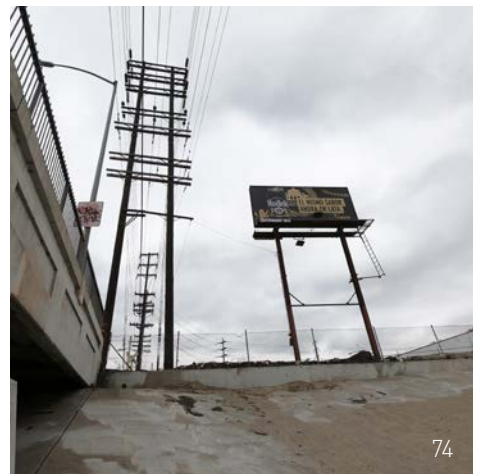

74

PATH TYPES

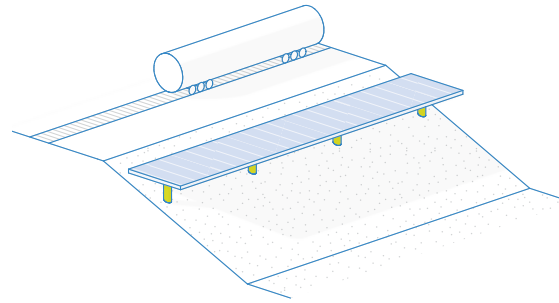
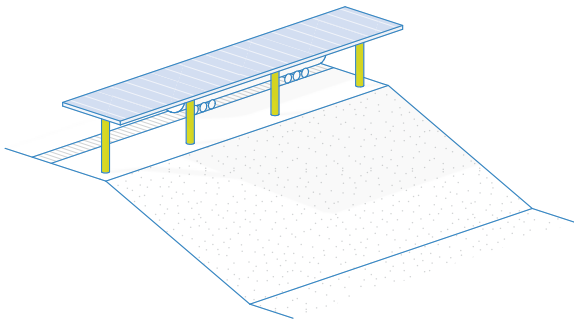

Four main path types are being considered for the LA River Path: elevated, top-of-bank, incised, and bottom-of-channel. These four main path types were presented to the community in January and February 2019 (see Chapter 9 for a summary of community input on path types). All of the path types include a range of trade-offs and potential for amenities, which are described in the following pages.

Elevated Path Types

ELEVATED TOP-OF-BANK

An elevated top-of-bank path type has a path supported by piers and foundations that anchor on the top-of-bank. This path type is valuable for ramping and crossing over roadways, rail, and other at-grade obstacles. It is located above the high water surface elevation allowing the path to be open year-round.

ELEVATED IN-CHANNEL

An elevated in-channel path type has a path supported by piers that anchor in the channel wall or bottom of the channel. This path type is valuable for ramping and crossing over existing bridges, passing underneath existing bridges, and navigating other at-grade obstacles, particularly in locations where an elevated top-of-bank path type is not feasible. It is located above the high water surface elevation allowing the path to be open year-round.

Potential for Amenities

Both elevated top-of-bank and elevated-in-channel path types have opportunities for lighting, shade structures, and amenities. Lighting and shade structures can be integrated directly into the structure, while the path deck would need to be widened to provide space for amenities such as seating. Due to cost and structural constraints, landscape cannot be integrated into an elevated path type.

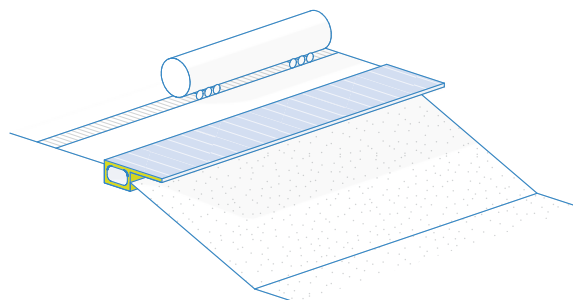
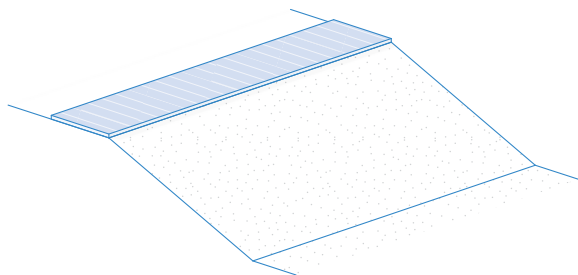

Top-of-Bank Path Types

AT-GRADE

An at-grade path type uses available space at grade for the path. This path type is the simplest and most cost effective construction, but is only feasible in select locations where rail lines and utilities are set back from the channel at a sufficient distance. An at-grade path will be located outside of the channel allowing the path to be open year-round.

Potential for Amenities

An at-grade path type has the greatest opportunity for lighting, shade structures, landscape, and amenities. In select locations with available adjacent space, such as between Soto Street and Downey Road, there could be space for seating and trees as well.

CANTILEVERED

A cantilevered path type uses a structure that hangs over the top of the channel wall but is supported at the top-of-bank. It would have an anchored base at top-of-bank with a path superstructure that hangs over the edge of the river channel. It would be unsupported on the river side. This path type is valuable where there is some available space at top-of-bank, but less than the width needed for a full path. For long stretches of the path where adjacent rail setbacks limit space, the cantilever could be an option to keep the path above the high water surface elevation, allowing the path to be open year-round.

Potential for Amenities

A cantilevered path type has opportunities for lighting, shade structures, and amenities. Lighting and shade structures can be integrated directly into the structure, while the cantilevered structure would need to be extended to provide space for amenities such as seating. In select locations where there is available space between the structure and the rail setback, limited landscape or green screens may be possible.

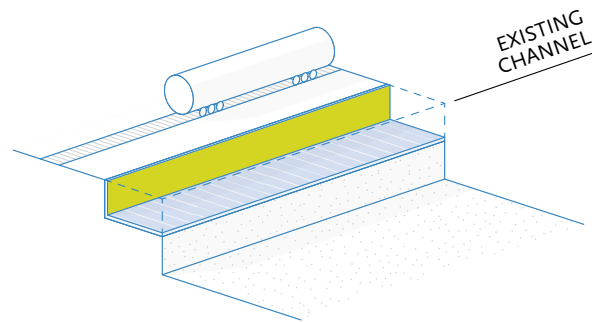
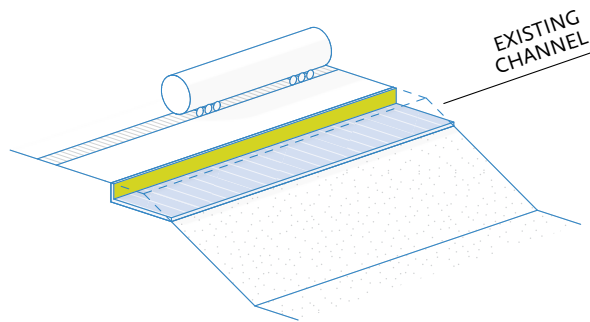

Incised Path Types

INCISED

An incised typology cuts the path into the channel embankment. This typology is feasible even when there is no available space at top-of-bank and can be located at different locations up or down the channel embankment. It is located partially within the channel; therefore, it requires a partial rebuild of the channel embankment. The pathway may fall below the water surface elevation based on channel conditions and could be at risk of seasonal flooding and potential path closures. Incised paths are used extensively along the existing LA River Path at bridge undercrossings.

BENCHED

A benched typology is a specific condition of incised path, where the path cuts into a rectangular or vertical wall channel. This typology is feasible even when there is no available space at top-of-bank. Located partially within the channel, it requires partially or completely rebuilding the channel wall. The pathway may fall below the water surface elevation based on channel conditions and could be at risk of seasonal flooding and potential path closures.

Potential for Amenities

An incised path (including benched) has opportunities for lighting and shade structures, but limited opportunity for other amenities. Lighting would need to be anchored at top-of-bank or from the underside of existing structures. Shade structures and other vertical amenities such as railings would need to be engineered to handle seasonal high water. Terraced seatwalls could be integrated into the structural rebuild of the channel wall. Landscape and most amenities would not be feasible due to potential seasonal flooding.

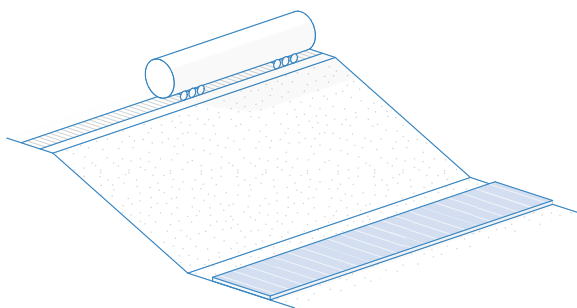

Bottom-of-Channel Path Type

BOTTOM-OF-CHANNEL

A bottom-of-channel typology locates the path on the flat bottom of the channel. It is one of the simplest typologies to build and is not impacted by adjacent top-of-bank conditions. Based on the physical corridor conditions, this path type is feasible in any location where there is not year-round water from channel wall to channel wall. However, a determination of what is feasible from a permitting and constructability standpoint will be subject to further hydrological studies and USACE permitting requirements. It is at high-risk of seasonal flooding and path closure, and requires long ramps to reach access points.

Potential for Amenities

A bottom-of-channel path type has very limited opportunity for lighting. Lighting would need to be anchored at top-of-bank or from the underside of existing structures. Landscape, shade structures, and other amenities would not be feasible due to potential flooding.

TRAVERSING UTILITY TOWERS

A combination of the path types described previously will be used to design a path that can traverse the corridor's complex physical constraints. In many cases, the path will need to navigate utility towers by going under, around, or through them, and existing bridges by going over, under, or through them.

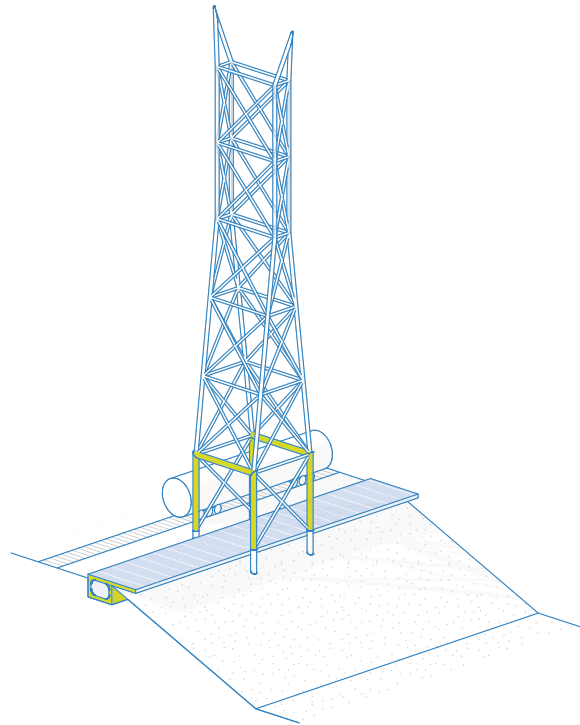

UNDER

In an under utilities typology, an at-grade, cantilevered, or incised path passes underneath an existing utility tower. This typology may require partially rebuilding the lower portion of the tower. This typology could be used where utility towers are large (20 feet wide) and obstruct the route at the top-of-bank.

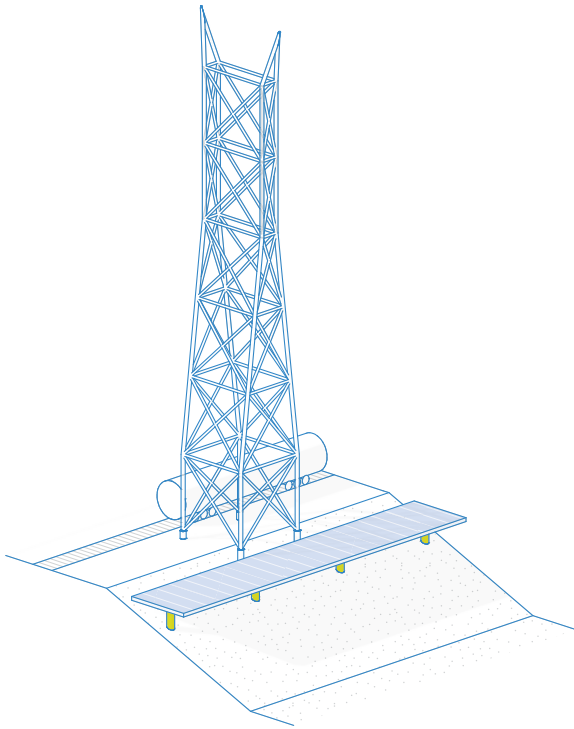

AROUND

Jogs a cantilevered, incised, or elevated path around an existing utility tower. This typology avoids impacting the existing tower but will impact the channel wall. It could be used where utility towers obstruct the route at the top-of-bank and are too small to pass through.

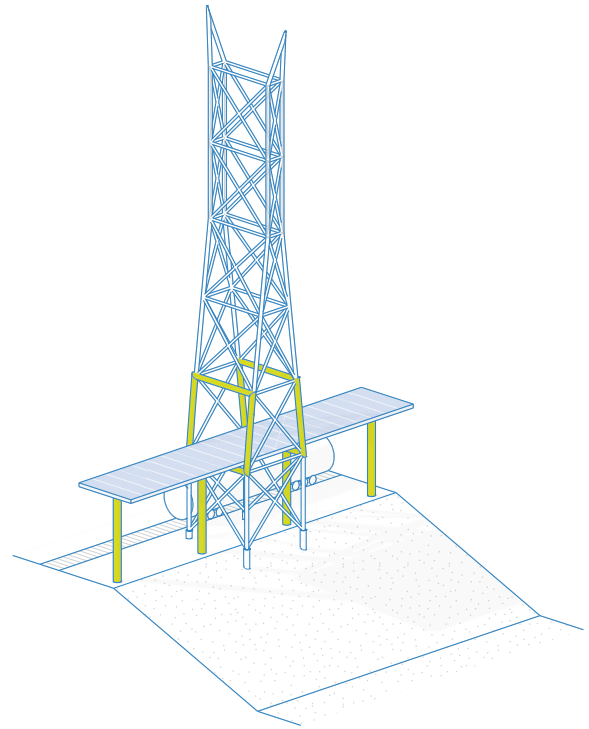

THROUGH

Passes an elevated path through an existing utility tower. This typology may require partially rebuilding the middle and lower portion of the tower. It could be used where utility towers are large (20' wide) and obstruct the top-of-bank route.

TRAVERSING EXISTING BRIDGES

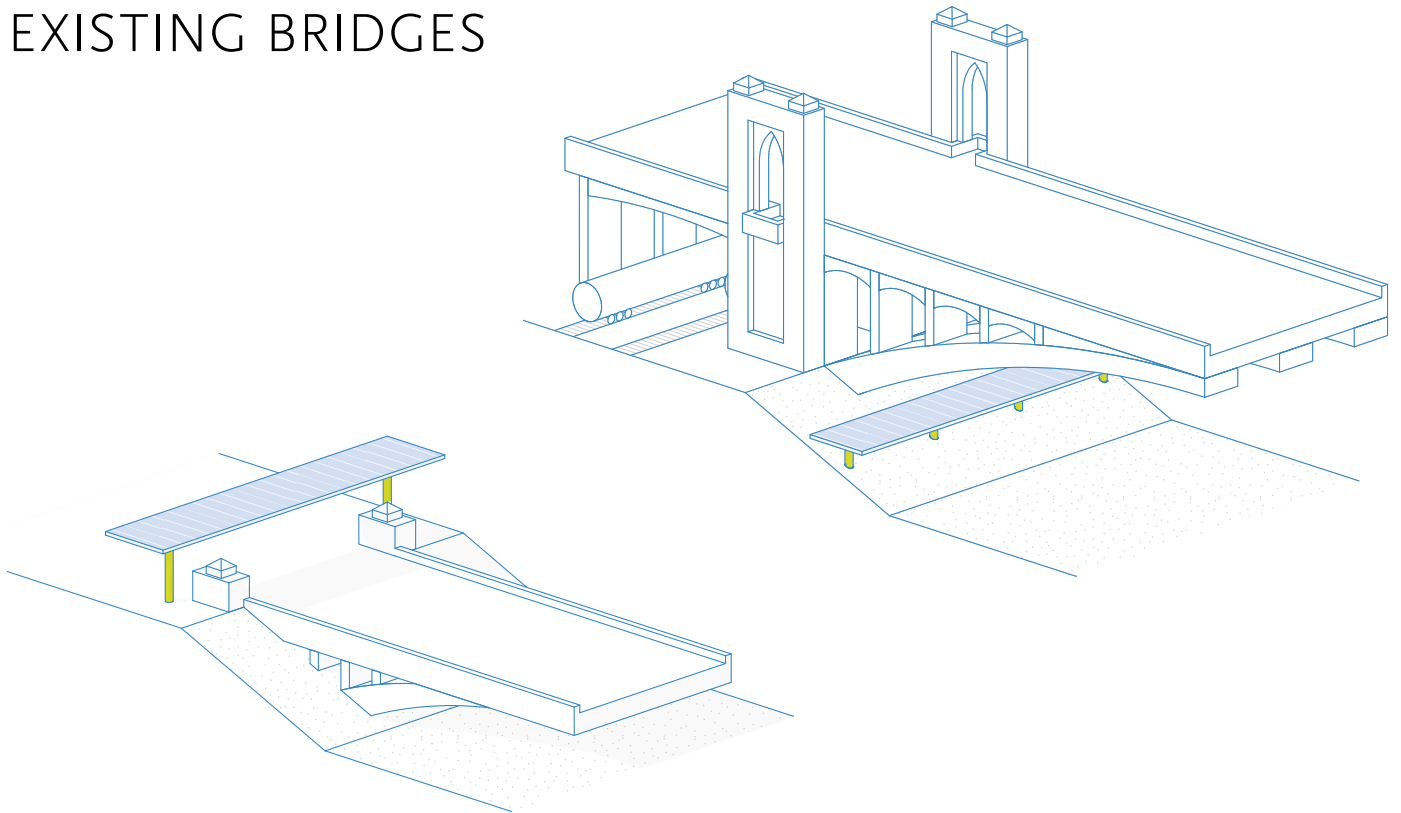

OVER

This typology uses an elevated path to pass over an at-grade bridge. This allows the path to avoid an at-grade crossing with rail or cars. It also allows the path to avoid passing underneath the bridge in locations where it is not feasible.

UNDER (ELEVATED)

This typology uses an elevated path to pass underneath the bridge. This would likely impact the channel wall with columns and the path may be at risk of seasonal flooding and path closures. It is also dependent on an individual bridge's footing and freeboard.

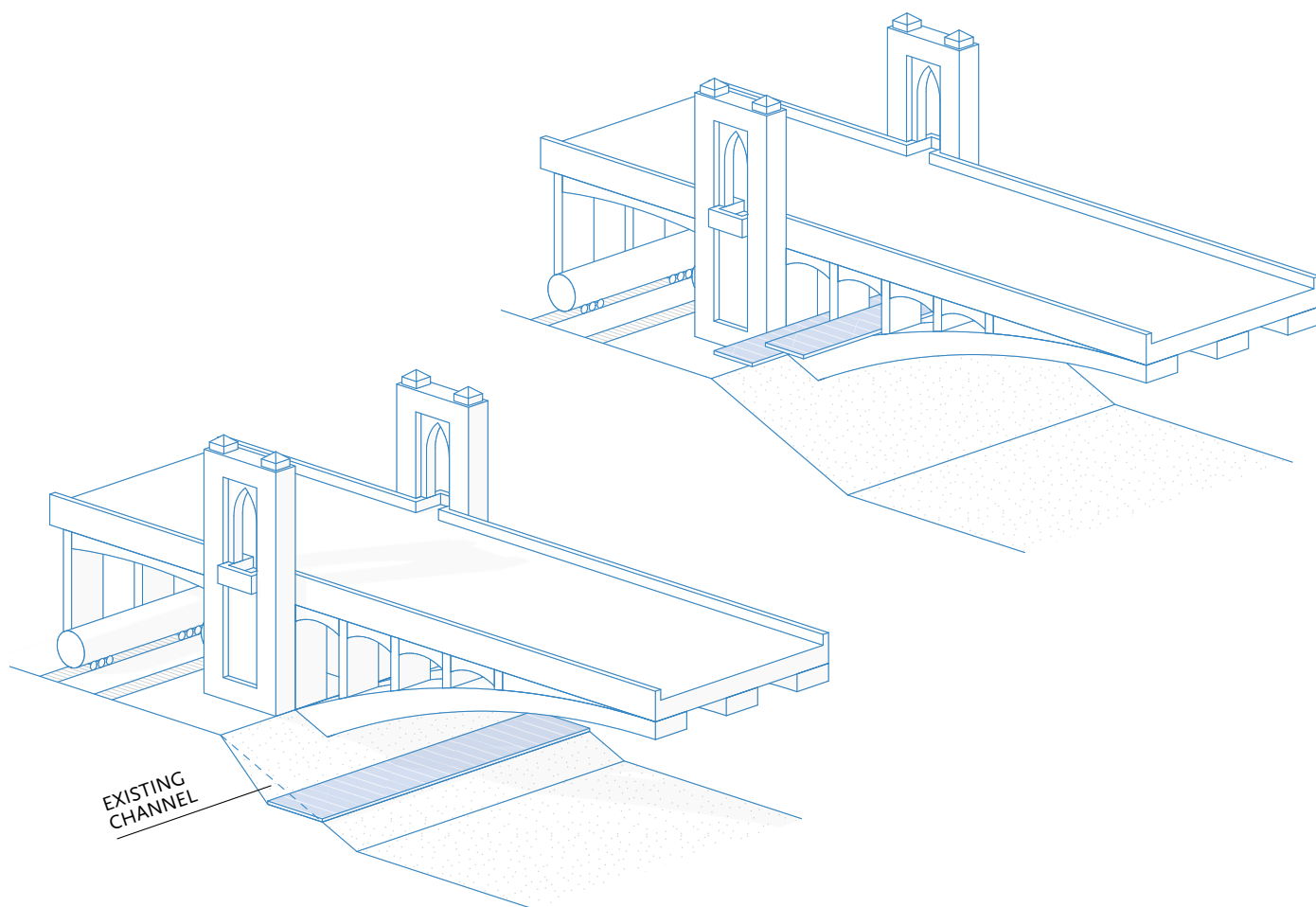

UNDER (INCISED)

An incised typology cuts the path into the channel embankment to pass under the bridge. This typology requires a partial to major reconstruction of the channel embankment and is at risk of seasonal flooding and path closures.

THROUGH

A through typology passes the path through portals in historic bridge architecture. It may require splitting the path through two portals if one portal is not large enough to accommodate the full path width. By not building a new bridge over the historic bridge, this typology is direct, minimizes view impacts of historic elements, and keeps the path above the water surface minimizing path closures. It does not impact the channel wall, but is the most challenging to construct.

STRUCTURES

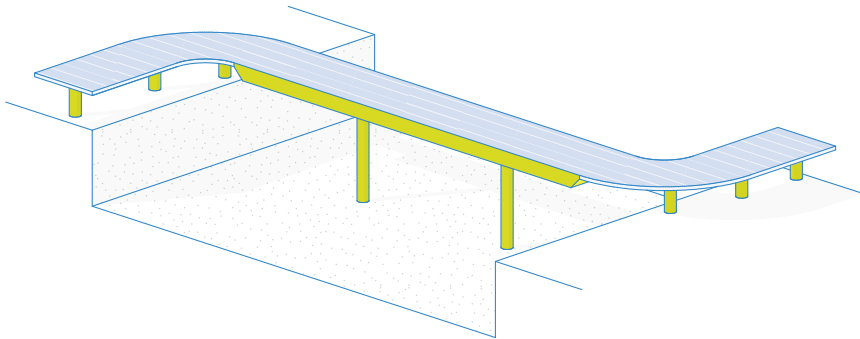

Channel Crossings

The LA River Path is anticipated to have several channel crossings. Channel crossings allow the path to best respond to site conditions and the project goals:

- **Constructibility:** River crossings allow the path to avoid locations that have significant constraints along the top-of-bank, as well as to minimize impacts to the channel hydrology. In many cases, the path's linear alignment may already be using an elevated path type, enabling the elevated structure to continue across the channel.
- **Access and Equity:** River crossings enable access points on both the east and west banks of the river. This allows for direct access to Equity Focus Communities (EFCs) such as Boyle Heights and Lincoln Heights on the east bank as well as direct access to major employment centers on the west bank.
- **Safety & Mobility:** River crossings allow the path to better connect with the existing and planned low-stress bicycle and pedestrian network, and allow users to safely cross the Los Angeles River. Many existing bridges over the Los Angeles River are major arterial roadways that do not have existing bicycle facilities that accommodate all ages and abilities and cannot be easily retrofitted.

There are hydrological and structural challenges to address for crossings. The Los Angeles River channel width ranges from 200' to 500', and most structures will require piers in the channel. Locations with existing hydrological constraints, such as a low freeboard, may prohibit adding piers to the channel and require a long-span bridge or custom design to mitigate. In general, the longer the crossing spans (distance between columns), the larger the footings and more costly the structure is to build.

Additionally, structure design needs to consider proximity to historic resources, available space for top-of-bank for footings, and transitions between the crossing and the continuation of the path.

Aesthetics and constructability will also play a part in determining the recommended structures. The outreach process will provide an opportunity for community input on the design of potential structures during the environmental phase.

Conventional Structures

Conventional structures include bridges with span lengths less than 300 feet, typically supported by reinforced concrete or steel beams. Conventional structures do not include arch bridges, complex trusses, or cable supported structures. In most situations, conventional structures provide direct routes while minimizing impacts to the existing river channel.

These structure types may involve utilizing reinforced concrete or fiber reinforced polymer bridge decks supported on steel or concrete beams (examples shown in photos 76 and 77). These beams would be supported by piers or sub-surface anchors that may consist of reinforced concrete columns.



PRECEDENT/INSPIRATION

75. Stevens Creek Pedestrian Bridge, Mountain View, CA

76. SR-28 Shared Use Path, Lake Tahoe, NV

77. Anacostia West Pedestrian Bridge, Washington DC

Custom Structures

Custom structures are structural solutions for unique and challenging existing conditions. As opposed to conventional structures which may have broad applications across the corridor, custom structures are relevant in a few key situations.

Custom structures can be used in areas that require long spans over the river channel and over rail and vehicular bridges. Truss structures offer flexible design, allowing opportunities for a curved path and long spans, while providing a unified design approach that responds to the LA River Path corridor constraints. For these reasons, custom truss structures were used to explore the constrained conditions along the project corridor.

As part of the conceptual design phase of this project, three custom structures were developed that respond to three unique sets of alignment constraints. Throughout the development of these custom structures, several structure types in addition to truss structures were considered, including conventional, arch, and cable stay bridges. The alignments and structure types shown are meant to represent possible design solutions to constrained conditions, as alignments and structure type are not finalized at this time.

A tubular truss could be reconfigured in several ways to create a consistent character of place, as seen in Figures 38–40. Cable stays, conventional truss, and arches can also be done in a similar fashion to create consistency and increase the user experience.

OVER/UNDER

The over/under scenario is relevant in situations where an at-grade and elevated bridge are in close proximity to each other, forcing the path to pass over one bridge and then under the other bridge. One example (Figure 39) is just south of Riverside Drive where a long-span bridge would have to pass 24 feet over at-grade rail line and remain elevated to pass underneath an adjacent elevated vehicular bridge, providing a minimum vertical clearance of eight feet above the path.

OVER/OVER

The over/over scenario is relevant in locations where the path connects key access points on opposite sides of the river that are both separated from the channel by existing rail. An example of this custom structure (Figure 40) is north of Broadway bridge where a singlespan truss structure spans across the river without impacting the middle of the channel. The structure maintains elevation to pass over rail on either side to provide access to both east and west access points. The structure also provides a ramp down to allow the LA River Path to continue at top-of-bank.

CLUSTERED BRIDGE CROSSING

This scenario is relevant in locations with limited areas for structure piers and multiple rail lines to cross that prevent a straight bridge from being used. An example is at Redondo Junction (Figure 41) where a singlespan truss structure could curve around and over multiple bridges while crossing the river without impacting the channel.

Potential Scenarios for Custom Structures

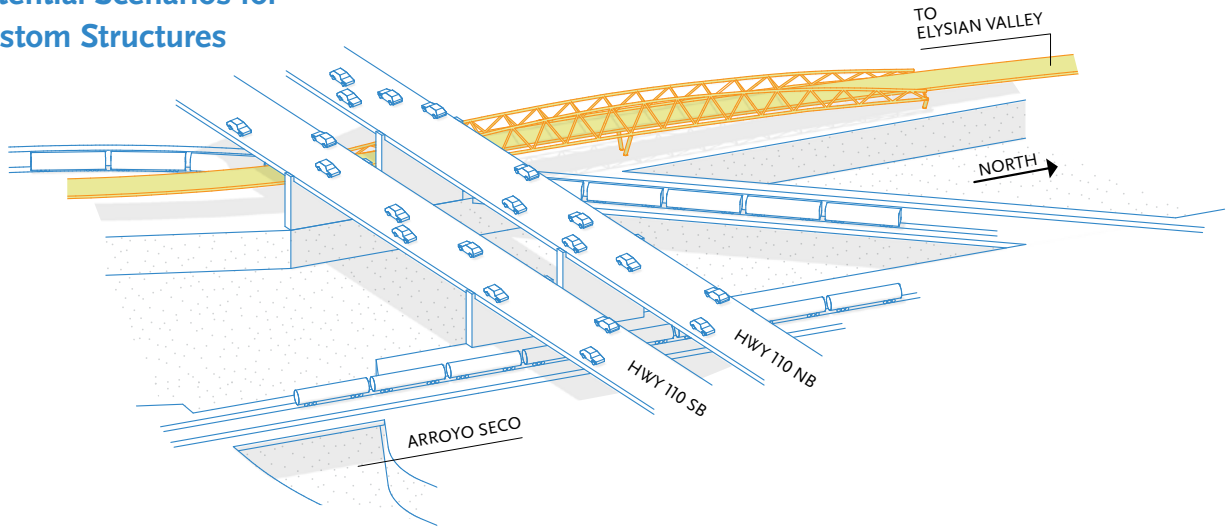

Figure 39. Over/Under Example at Highway 110*

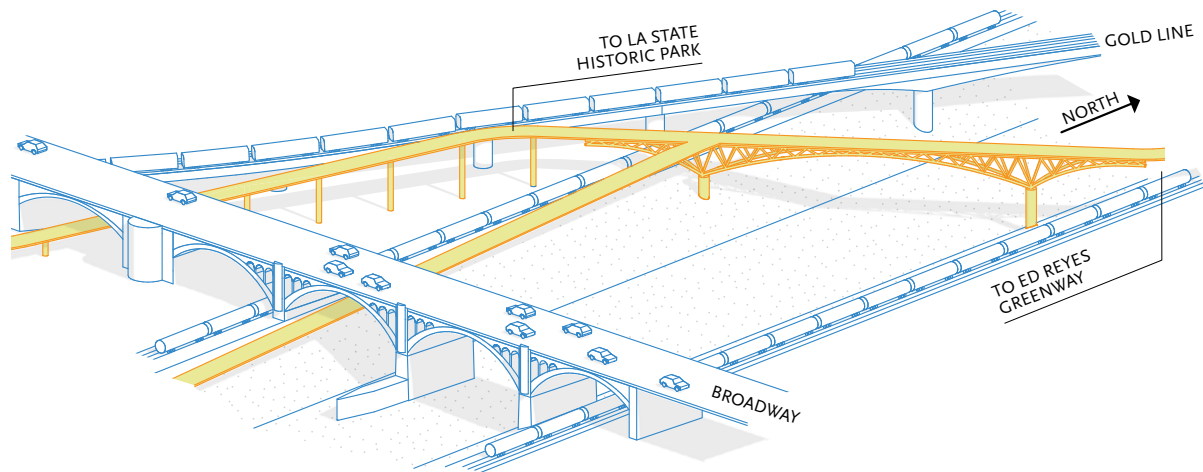

Figure 40. Over/Over Example North of Broadway Bridge*

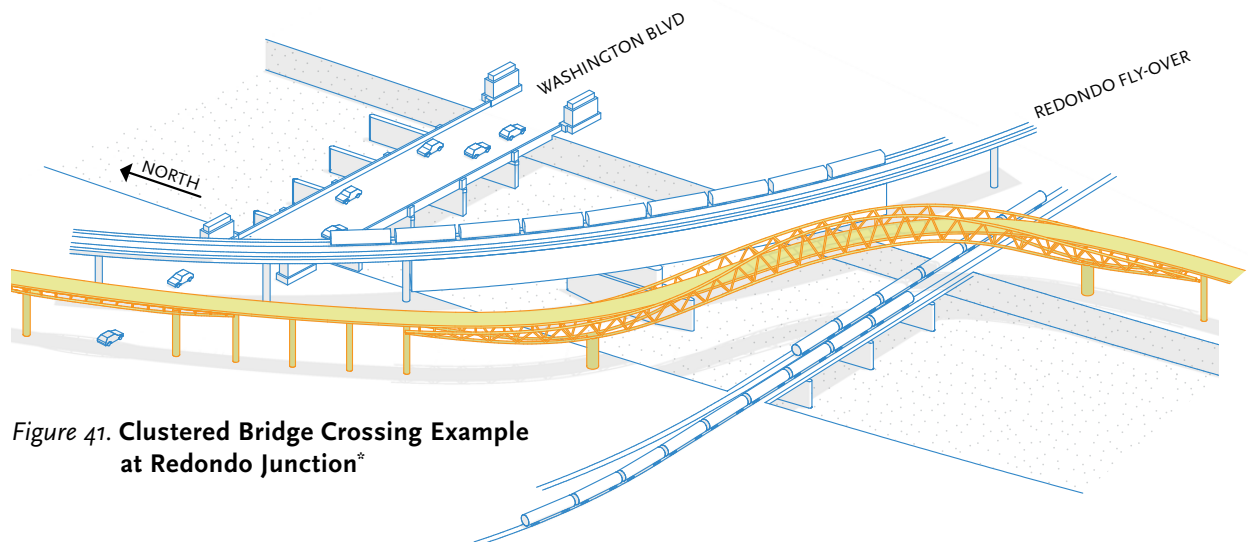

Figure 41. Clustered Bridge Crossing Example at Redondo Junction*

*Illustrative example of one structure option under consideration.

The precedents shown at right provide examples of custom bridges that have solved similar constraints seen along the LA River Path corridor. These include traversing railways, roads, and rivers, and interacting with historic structures.

The North Bank Pedestrian Bridge in Boston, MA (see photo 78) weaves over a railway, under a highway bridge, and over Miller's River. The tubular steel truss bridge features fiber reinforced polymer decking.

Metro's Universal City Pedestrian Bridge, in Los Angeles County, CA (see photo 79) is an L-shaped tubular steel truss bridge that connects Metro's Red Line Universal City Station with Universal Studios over two legs of a busy intersection.

The Nigtevecht Bridge (see photos 80 and 81) is a bicycle bridge over the Amsterdam Rhine Canal in the Netherlands which features gradual, user-friendly ramps in a constrained area. Staircases are also provided for pedestrians to bypass the ramps.

Finally, the Harlech Castle Footbridge in Wales (see photo 82) provides an example of contemporary architectural design that connects to a historical structure.

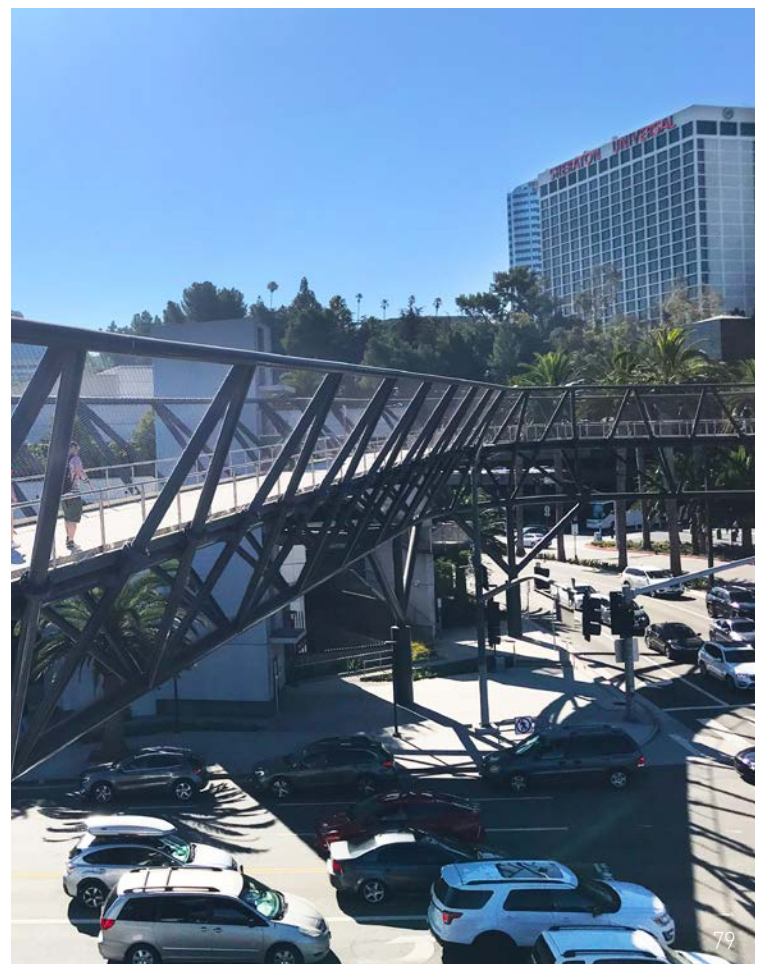
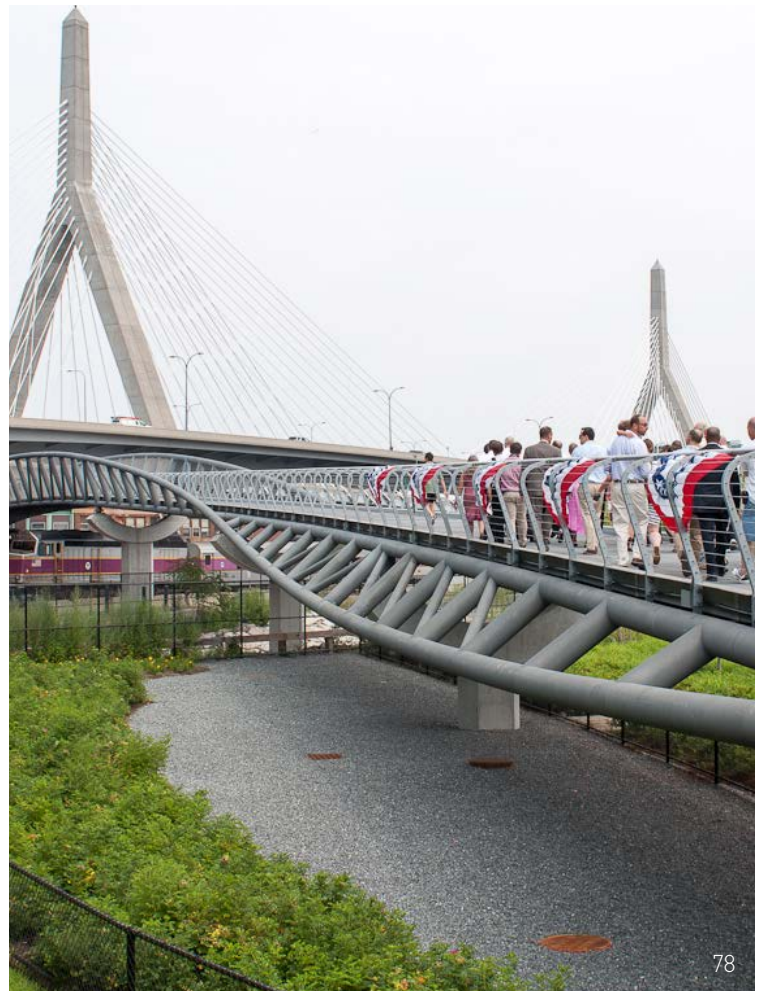



80



81





82

PRECEDENT/ INSPIRATION

- 78. North Bank Bridge, Boston MA
- 79. Universal City Station Pedestrian Bridge, Los Angeles, CA
- 80. Nigtevecht Bridge, Amsterdam, Netherlands
- 81. Aerial view of the Nigtevecht Bridge, Amsterdam, Netherlands
- 82. Harlech Castle Footbridge, Harlech Castle, Wales

Table 5. Structure Types

Table 5 provides a comparison of the various conventional and custom structure types. Each structure type has different benefits and challenges to consider. As the project moves forward, structure types in consideration for the LA River Path will be evaluated based on specific site constraints and needs.

Conventional Structures			
	SHORT SPAN CONVENTIONAL BRIDGE	MEDIUM SPAN CONVENTIONAL BRIDGE	MEDIUM SPAN PREFABRICATED STEEL TRUSS
			
SPAN RANGE	30–100 feet	100–250 feet	75–250 feet
DESCRIPTION	Concrete or fiber reinforced polymer decks supported on steel or concrete beams spanning between columns.	Concrete or fiber reinforced polymer decks supported on steel or concrete beams spanning between columns.	Trusses on each side of the path support the structure between support locations.
RELATIVE COST	\$ \$	\$ \$	\$ \$
COST RANGE <i>\$/square foot</i>	\$200–\$500	\$200–\$500	\$200–\$500
BENEFITS	Shorter spans are easier to transport and require smaller equipment to erect. Shorter spans weigh less and require smaller foundations to support vertical and lateral loads.	Longer spans require fewer foundations, reducing foundation cost.	Can be fabricated off site. Relatively light for shipping and assembly on-site. Can be shipped in shorter segments and bolted together at the project site.
CHALLENGES	Requires more foundations. Aesthetics of relatively closely spaced columns may give a congested feel. Shorter spans lend themselves to shallower support beams between columns.	Requires fewer foundations, creating a more open feel. Longer spans weigh more, resulting in foundations that are larger in order to support higher loads. The depth of support beams between columns increases with span length.	Can only be used on tangent alignments. Curves in the path alignment must be handled with chords between support locations. Relatively heavy and industrial aesthetic. Difficult to use with very wide paths.

Custom Structures

CUSTOM STEEL TRUSS

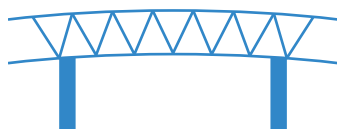

100–300 feet

Truss members can be fabricated in different configurations to support the path from either below or above the path.

\$\$\$\$

\$500–\$2000

Allows for longer spans with fewer supports. Opportunity to customize visual aesthetics. Provides opportunity to provide landmark along the path. Can accommodate curved alignments.

Design and construction are both more specialized than conventional construction. Higher cost associated with non-standard fit up of truss members.

ARCH

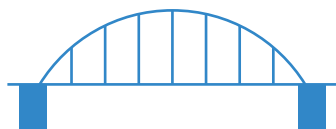

100–450 feet

Cables hanging from arches can be used to support the path, or the path can be supported by an arch constructed below the path.

\$\$\$\$

\$500–\$2000

Allows for very long spans with fewer supports. Opportunity to customize visual aesthetics. Provides opportunity to provide landmark along the path.

Longer span structures require larger foundations to support the structure. Higher cost compared to conventional construction. Difficult to accommodate curved alignment.

CABLE STAY

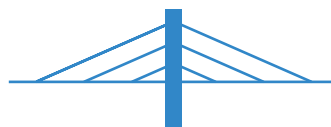

400–1500 feet

Cables suspended from large towers support the path.

\$\$\$\$

\$500–\$2000

Allows for extremely long spans with fewer supports. Opportunity to customize visual aesthetics. Provides opportunity to provide landmark along the path.

Towers require large foundations to support the structure. Higher costs are associated with foundations and specialized labor.

MODULAR DESIGN

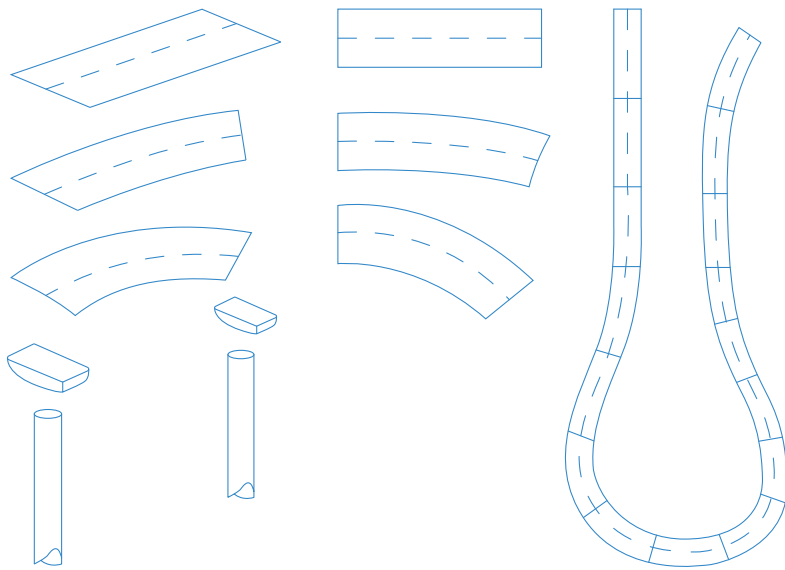

Figure 42. Example of prefabricated bridge deck elements

Modular Design Principles for Bridge Design and Construction

Modular elements may be used to offer flexible, customizable bridge solutions that consist of prefabricated elements that can be constructed off-site, delivered to the project site, and efficiently assembled and placed on-site. In the process of designing the bridges on the LA River Path, modular design elements can be used for bridge decks, superstructure elements (girders), and railings. Columns and pier caps may be able to be used, provided appropriate seismic connections are incorporated into the design. Modular designs combine both aesthetic and functional design, relating to production, transportation, assembly, and maintenance.

Modular Bridge Design Elements:

- Prefabricated bridge deck elements, such as concrete or fiber reinforced polymer
- Super structure elements, such as precast concrete girders, steel girders, steel trusses
- Railings
- Pier caps
- Columns

Benefits and Considerations

BENEFITS

Speed Up Construction Process

Perhaps the biggest benefit of using prefabricated bridge elements is the potential to reduce construction time when compared to traditional on-site construction. By using prefabricated bridge elements, time for falsework construction, form and rebar placement, and concrete curing is eliminated. As project durations increase, so do construction costs. Using prefabricated bridge elements to reduce construction time will reduce construction costs.

For Los Angeles, By Los Angeles

Local production can have multiple benefits, as taxpayer money is invested into the local economy, not only funding the LA River Path, but also stimulating the economy and creating jobs. For instance, modular steel bridge sections could be manufactured by a local steel company. At minimum, the biggest benefit to the community would likely be employment of construction workers on site.

Flood Risk Mitigation

In addition to reducing construction schedule and cost, another benefit of using prefabricated bridge elements is reduced environmental impacts and risks. As the project is in a flood-prone area, the ability to mitigate flood risks during construction is an important one. Prefabricated bridge elements are produced off-site, reducing the need for long-term construction sites along the river. As an example, falsework to support the superstructure will not need to be constructed in the river, minimizing the contractor's risk to damage of their temporary works during a flood event. In addition, this approach prevents the need for evacuation and quick removal of the construction site during a flood event.

Innovating Efficient Use of Materials and Energy

Modular bridge components offer the opportunity to include innovations and techniques that focus on reducing material use, and waste, an efficient production process, and overall minimization of the carbon footprint of the components.

Adaptable to Future Needs

Assembling a bridge with modular elements can create a flexible system that could be modified to accommodate future needs.

CONSIDERATIONS

Custom Design Using Standardized Components

A modular design for a bridge will offer a customized solution for the bridge and its unique context. Developing the bridge modules using as much standardized materials and components as possible can help to manage cost and availability of building materials.

Integrated Process of Designing and Building

Developing a modular design involves extra effort to coordinate between designer, engineer, and fabricator. Production techniques needed to fabricate the design need to be identified early on in the design process. Specialized software (BIM) can be used to improve and speed up collaboration with designers, engineers and other specialists.

Modular Bridge Element Size

A key consideration is the type, capacity, and availability of production facilities that would be needed to produce these modules. Defining a somewhat standard size can be beneficial, so that most production facilities will be able to manufacture that specific part; very large components might have very limited availability of potential manufacturers.

Transporting Bridge Elements

Transport of prefabricated bridge elements will depend on where the bridge modular elements will be produced, the distance of production facilities to the Los Angeles River, and the means of transportation of prefab elements. Large modular element dimensions are generally determined by transportation restrictions on local roads and railways.

This page intentionally left blank



07

CHARACTER OF PLACE

Why is this important?

The term “character of place” includes all of the tangible elements that come together to create an outstanding user experience along the LA River Path. Character of place builds upon existing community assets and expresses a unifying theme that will influence design decision and the resulting articulation of form.



How does it apply to the LA River Path?

Creating a high-quality, world-class active transportation corridor requires going beyond basic path design principals.

Chapter 7 highlights the elements that may be used along the corridor to create an outstanding user experience from public art and lighting to site furnishings and landscape.

DESIGN VISION: FUNCTIONAL ELEGANCE

The LA River Path seeks to utilize a simple and multi-functional design vision. Functional Elegance is driven by Metro's approach to transportation projects and the Vision 2028 goal of delivering an outstanding user experience. Materials such as concrete, glass, and stainless steel, which can be seen in use at Metro rail stations, are durable and can withstand wear and tear, can be maintained to a high standard, and can capture the vision of a functional and elegant path.

In order to create a world class facility, a high quality design vision must be created. The community input received expressed the importance of a high quality user experience. Design themes, along with elements such as art, lighting, and landscape, will work together to create a high quality user experience.

Design Themes

A design theme is a unifying and recurrent idea which is made clear through recognizable elements such as patterns, forms, colors, textures and materials. These elements may be used in different combinations to create an environment that is both familiar throughout and recognizable at each location.

The following four examples provide potential design themes that could be relevant for this project. The design theme for the LA River Path will be developed through community engagement, preferences, and input during future phases of the project.

CONVERGENCE AND CONFLUENCE

Celebrate communities and local traditions that link the path to its surroundings through form, materials, patterning, and creating space for artistic opportunities.

THE RIVER AS ENERGY SOURCE

Investigate ways to harness and highlight the energies that flow through the Los Angeles River corridor, such as solar, water, winds, human kinetic energy, and the surrounding power grid.

LIGHT AND SHADOW

Prioritize access to shade, water, and green space to make the LA River Path an oasis within the city.

MOUNTAINS TO THE OCEAN

Encourage a feeling of connection and continuity with the cities, towns, and landscapes surrounding Los Angeles.

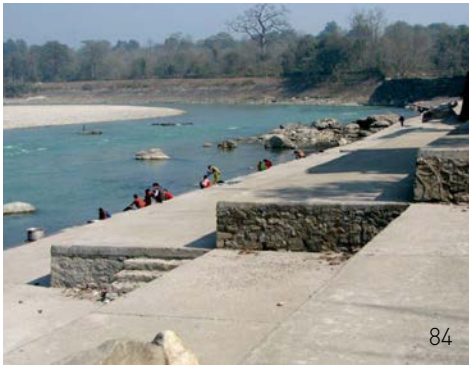

84

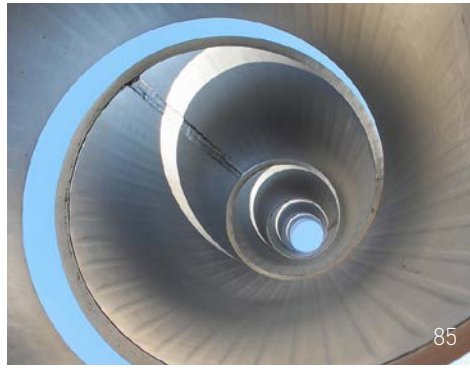

85



86



87



88



89



90



91

PRECEDENT/INSPIRATION

84. River Embankment, Bharatpur, Nepal

85. Steel Sculpture

86. Passerelle Simone de Beauvoir, Paris, France

87. Santa Monica, CA

88. Double Exposure

89. Glacier Skywalk, Alberta, Canada

90. The Xiamen Bicycle Skyway, Xiamen, China

91. The Hovenring, North Brabant, Netherlands

ART

Art Along the River

Site-specific artwork has the ability to deepen connection to place, cultivate a sense of pride and stewardship and improve the LA River Path experience for users. An art program will be integrated into the LA River Path and may be realized in a variety of media to foster a cohesive and distinctive character of place and user experience. Artwork opportunities are maximized when true collaboration across art, engineering, architecture and community engagement progress together within the overall project design. This holistic approach is in line with the overall design concept, is grounded in lessons learned and is exemplified by existing Metro projects. The art program may manifest as artist designed/ influenced infrastructure including bridges, lighting, furnishings, gateways, landmarks, as well as other site-specific sculptural elements and programming opportunities.

The Los Angeles River is home to a multitude of formal and informal, temporary and permanent artworks in every medium, including performance, virtual reality, sculpture, mural and graffiti. Cultural expressions are visible from artist Leo Limon's "famous gatitas" or *RiverCATz* painted on circular storm drains to participatory actions led by artist Rafa Esparza to honor community memories of the river. A significant artwork by artist Lauren Bon and the Metabolic Studio, *Water Wheel*, will be positioned near the site of an original water wheel on the south side of the North Broadway Bridge, that, in the 1860s, brought water back to Los Angeles.

The LA River Path will consider opportunities for large-scale iconic artwork, artist-designed infrastructure and functional elements as well as artwork that links disparate built elements and social dimensions of the 8-mile alignment with a thematic thread. The art program will build on existing cultural assets and encourage meaningful engagement with the LA River Path.

Public art may be integrated into the structures found along the LA River Path, both in the structural elements and design of the bridge structures, as well as along the underside of the bridging decks. The details of public art along the corridor will be determined later in the project design, in conjunction with community members and local artists.

Art at Metro

AN INTEGRATED APPROACH

Metro's approach to public artwork is informed by early engagement with the project team and communities. Art on the LA River Path may be integrated with path infrastructure such as bridges, lighting, furnishing and wayfinding. It may also manifest as a stand alone sculpture, sculptural elements and/or art elements that offer programmable spaces for the public to activate over time.

The first phase of arts-based public outreach will reveal and engage existing cultural

expressions and community visions for what art can do for the LA River Path. Public outreach will highlight arts and culture that already exists and thrives as well as community visions for what arts and design can do for the project.

METRO'S ARTS & DESIGN DEPARTMENT

Metro Arts & Design leads the integration of art along the LA River Path. Taking a holistic view of the path design enhancements early in the process informs artwork opportunities that reinforce a unified character of place and improve the user experience.

MAINTENANCE CONSIDERATIONS

Based on lessons learned, Metro-commissioned permanent artworks utilize durable materials that ensure longevity and ease of maintenance. Public art may require special maintenance considerations and will be integrated into the path O+M Plan. For more information on the development of an O+M Plan, see page 29.

PRECEDENT/INSPIRATION

- 92. Gold Line Bridge, Andrew Leicester, Los Angeles, CA
- 93. Patsaouras Plaza Wind Bridge mockup, Ned Kahn, Artist and Gensler, Architect, Los Angeles, CA
- 94. "Origins" Debra Scacco, Los Angeles, CA



LIGHTING

Light Along the Path

Lighting is more than a safety requirement—it can transform and shape the user experience of place and may be a platform for artwork. Light adds to the path user experience by creating a welcoming environment that allows people to be seen and see others and increases safety, and the perception of safety, a critical consideration for path users.

Light is dynamic and can express a range of unique qualities: color, tone, pattern, and texture. The LA River Path can use lighting design to elevate user experience and reinforce design themes to achieve project goals.

Lighting Typologies

There are three main lighting considerations for the LA River Path:

- **Form:** The physical form of the lighting elements and their associated costs should be considered. Lighting can be integrated into other path elements, such as structures, railing, and site furnishings.
- **Function:** Various power sources may be more or less appropriate from a budgetary, operations, and maintenance standpoint.
- **Experience:** Lighting conditions could be manipulated to create a unique path experience and reinforce design themes.

PATH-INTEGRATED

Lighting can be incorporated into other elements of the path, such as furniture, railings, retaining walls, wayfinding elements, and the path material itself. Lighting incorporated into site furniture is typically done using LED strip lights protected by a channel.

POLE-MOUNTED

Standalone lights may also be used along the path. Cost for solar or wired pole-mounted lights is approximately the same. These fixtures can be integrated into art and wayfinding opportunities to reinforce design themes.

FLOOD LIGHTS

The walls of the river channel, bridges, and utility towers are all vast canvasses that can be activated and transformed by light.

PROGRAMMABLE DATA INTERPRETATION AND PATTERNING

Data from any type of environmental sensor, patterns, or images can be programmed to be interpreted as light. Each such installation will require connection to a climate-controlled server. Opportunities to co-locate these elements with other infrastructure that will require similar systems, such as elevators, may minimize cost.

MAINTENANCE CONSIDERATIONS

Lighting products that are durable and feasible to maintain to a high standard will be implemented, based on input from other path operators. Theft of lighting materials, such as copper wiring, has occurred along the existing path. Therefore, alternatives to hard-wired lighting and appropriate operations and maintenance procedures will be considered to reduce risk.



95



96



97

PRECEDENT/INSPIRATION

95. The Cycle Snake (Cykelslangen), Copenhagen, Denmark

96. Dolder Bridge, Steenwijk, the Netherlands

97. "Under LA" by Refik Anadol + Peggy Weil, commissioned by Los Angeles Department of Current Affairs, Los Angeles, CA

98. Van Gogh-Roosegaarde Bike Path, Eindhoven, Netherlands



98

WAYFINDING

Wayfinding Along the Path

The LA River Path wayfinding system will provide navigational assistance to people moving through the complex urban environment by increasing the legibility along the path. Wayfinding also increases safety by informing path users of their location in case of an emergency.

A comprehensive approach to wayfinding uses architectural elements, materials, and the landscape in conjunction with signage and environmental graphic displays (SEGD) to create an intuitive experience. Wayfinding can create a deeper connection to a place and improve the user experience, cultivate a sense of pride by reflecting community values and identity, and support local economic development by encouraging residents and visitors to access businesses and services.

Signage and Environmental Display

DIRECTIONAL SIGNAGE

SEGD often includes signage elements that are used to guide people through the path and to local landmarks and destinations nearby. These elements are designed at a human scale and may include directional signs, information kiosks, and map panels.

As this LA River Path project sits within the greater Los Angeles River corridor, coordination with project partners is important to create a clear and consistent wayfinding system. This will involve coordination with Metro's SEG D Department, the County of Los Angeles, and surrounding cities.

INTERPRETIVE SIGNAGE

There may be opportunities for the path to include information that provides the user with environmental context and helps them interpret their surroundings. Interpretive or educational information may include cultural topics such as native tribes and early settlers to the area, as well as historic milestones and events.

There may also be an opportunity for project partners to include interpretive signage relating to the ecology and revitalization of the Los Angeles River, and the culture and history of adjacent neighborhoods.

MAINTENANCE CONSIDERATIONS

Wayfinding elements should be constructed of high quality materials that are durable for the projected life-span of the project. Where vandalism is a threat, modular components may be considered, as they are more flexible and allow for smaller pieces to be replaced as needed (rather than replacing an entire unit). As applicable, protective graffiti resistant coatings may also be applied.

PRECEDENT/INSPIRATION

Photos, opposite:

99. CV Link, Coachella Valley, CA

100. Zoom in of Kiosk at CV Link, Coachella Valley, CA

101. Abalone Cove Reserve, Rancho Palos Verde, CA

102. Razorback Greenway, Bentonville, AK

103. Waterfront Promenade Kelowna BC Canada



SITE FURNISHINGS

Furnishings Along the Path

Site furniture facilitates comfort along the path, providing places for people to pause and rest, exercise, play and interact with fellow users.

Furnishing Typologies

The LA River Path may include furnishings to satisfy basic comfort and safety along the path. Examples of possible site furnishings include shade structures, seating and water fountains, trash and recycling, bicycle amenities, and shared mobility resources.

SHADE STRUCTURES

The majority of the river corridor is unprotected from the sun. Integrating shade structures into the path will improve comfort and the user experience.

SEATING AND WATER FOUNTAINS

The path may include seating elements immediately adjacent to the path. Water fountains may also be provided for users.

TRASH AND RECYCLING

Providing places to dispose of trash and recycling may help to encourage stewardship both of the path and the river itself.

BICYCLE TOOLS AND LOCKERS

Providing clearly delineated and secure places to lock bicycles and scooters may improve the user experience. Bicycle fix-it stations typically provide tools for minor repairs.

SHARED MOBILITY RESOURCES

Shared mobility resources may include space for equipment, information on instructions for use and registration, or charging stations.

MAINTENANCE CONSIDERATIONS

Site furnishings should be well maintained to ensure a safe and outstanding user experience. Durable materials, such as concrete, glass, and stainless steel, may be implemented to withstand normal wear and tear and vandalism.

PRECEDENT/INSPIRATION

Photos, opposite:

- 104. Vistula Boulevards, Warsaw, Poland
- 105. Kalvebod Waves, Copenhagen Harbour, Denmark
- 106. Upper West Side Benches, Manhattan, NY
- 107. Vistula Boulevards, Warsaw, Poland
- 108. Vistula Boulevards, Warsaw, Poland
- 109. Metro Bike Share, Los Angeles, CA



104

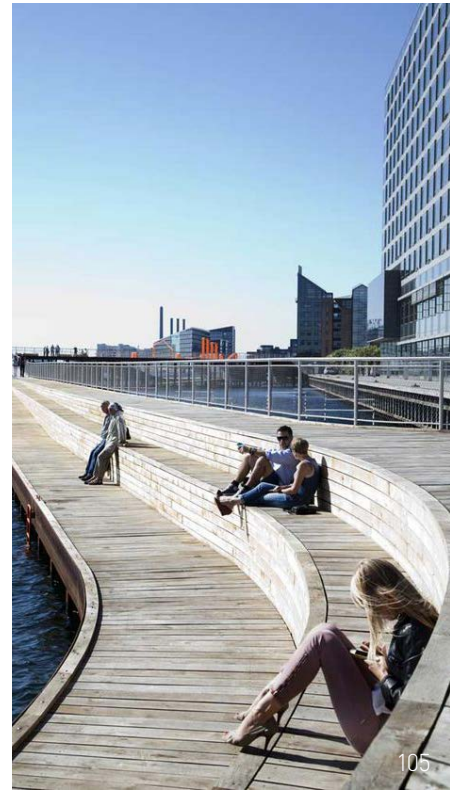

105

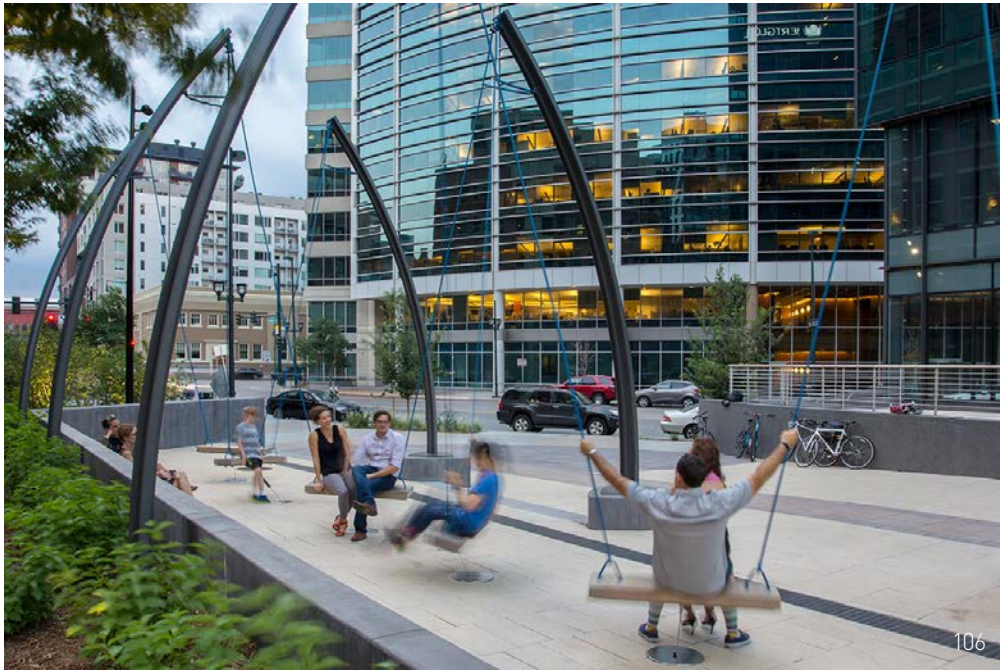

106

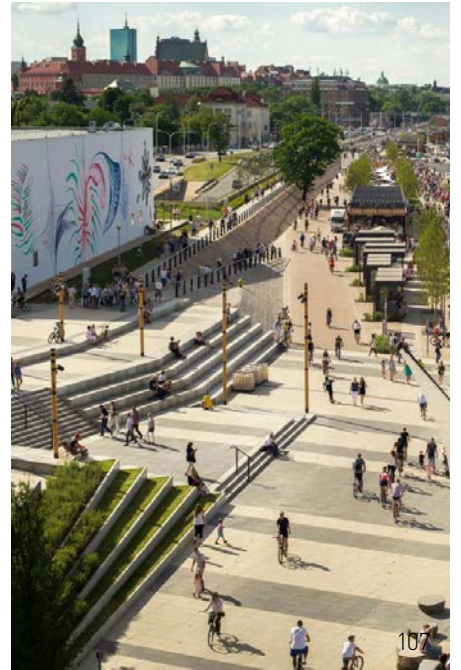

107



108



109

LANDSCAPE

Landscape Along the Path

Landscape can transform an urban space into a comfortable and calming environment, enhance sense of place and community identity, and deepen connections to the cultural and environmental history of a region.

The LA River Path project will primarily focus on providing landscaping at access points. While there are many ongoing efforts to add landscape to the Los Angeles River, these efforts are considered part of the larger Los Angeles River revitalization and are being implemented as part of ongoing efforts by county and city agencies.

Landscape at Access Points

Landscape design can be used at access points to highlight gateways to different neighborhoods along the LA River Path, and to create a sense of place and provide amenities for nearby communities. Landscape areas will complement and help frame access points with clusters of plant species that highlight the path and amenities.

Based on the scale and context of the access point, the landscape component may range from minimal accent and buffer plantings to larger plantings with sizable canopy trees. The landscape may be used to provide shade, reduce urban heat island effect, and enhance aesthetics.

Where access points are directly adjacent to the Los Angeles River channel, USACE and LARMP setbacks and guidelines will be observed.

PLANT PALETTES

Suggested plant palettes have been developed to serve three goals: to link the LA River Path to the larger Los Angeles River and Southern California ecosystem, to create a strong sense of place for the eight miles of the LA River Path, and to respond to the character and culture of the unique communities the path passes through.¹

LANDSCAPE DESIGN

The design of the landscape blends the functional elegance of the LA River Path with the natural character of the Los Angeles River. Native species that historically flanked the banks of the river may be used to bring color and life to access points. Only species that are drought tolerant and low-maintenance will be considered, such as native trees that provide shade, abundant grasses and sedges, and native shrubs.

Swaths of different colors and textures of plants can be used to create depth and interest, while high-branching trees can visually break up the landscape and hardscape to create shade while maintaining views and sightlines.

¹ Metro. 2019. *LA River Path Project Landscape Assessment*. Los Angeles, CA.



110

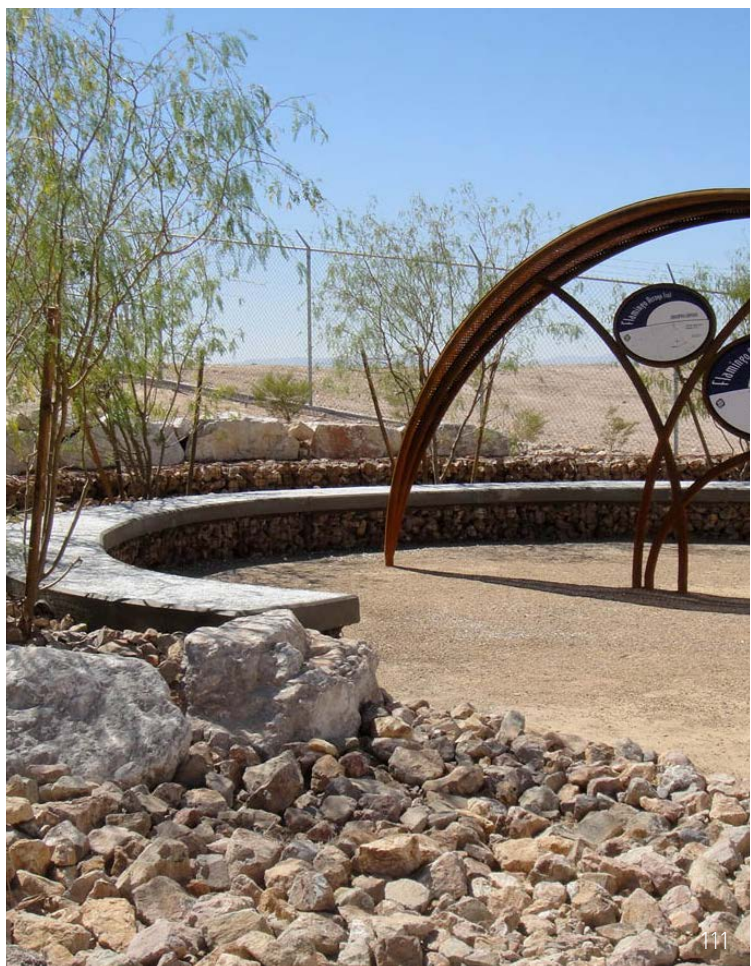

111



112

PRECEDENT/INSPIRATION

110. Sunnylands Center & Gardens, Rancho Mirage, CA

111. Flamingo Arroyo Trailhead, Las Vegas, NV

112. University of Texas, El Paso, TX



08

GETTING TO THE PATH

Why is this important?

Accessing the path should be intuitive, convenient, and comfortable for users of all ages and abilities. Path access points can be located and designed in such a way that they reinforce the project mission of creating a world-class user experience for the communities that live near the Los Angeles River today.



113 Chapter 9

113

How does it apply to the LA River Path?

Access points and connections to other mobility options, such as on-street bicycle and pedestrian facilities and public transit, will ensure the path is a functional and enjoyable part of the transportation network of Los Angeles. Chapter 8 outlines access point opportunities, associated elements and amenities, and opportunities for community connections.

ACCESS OPPORTUNITIES

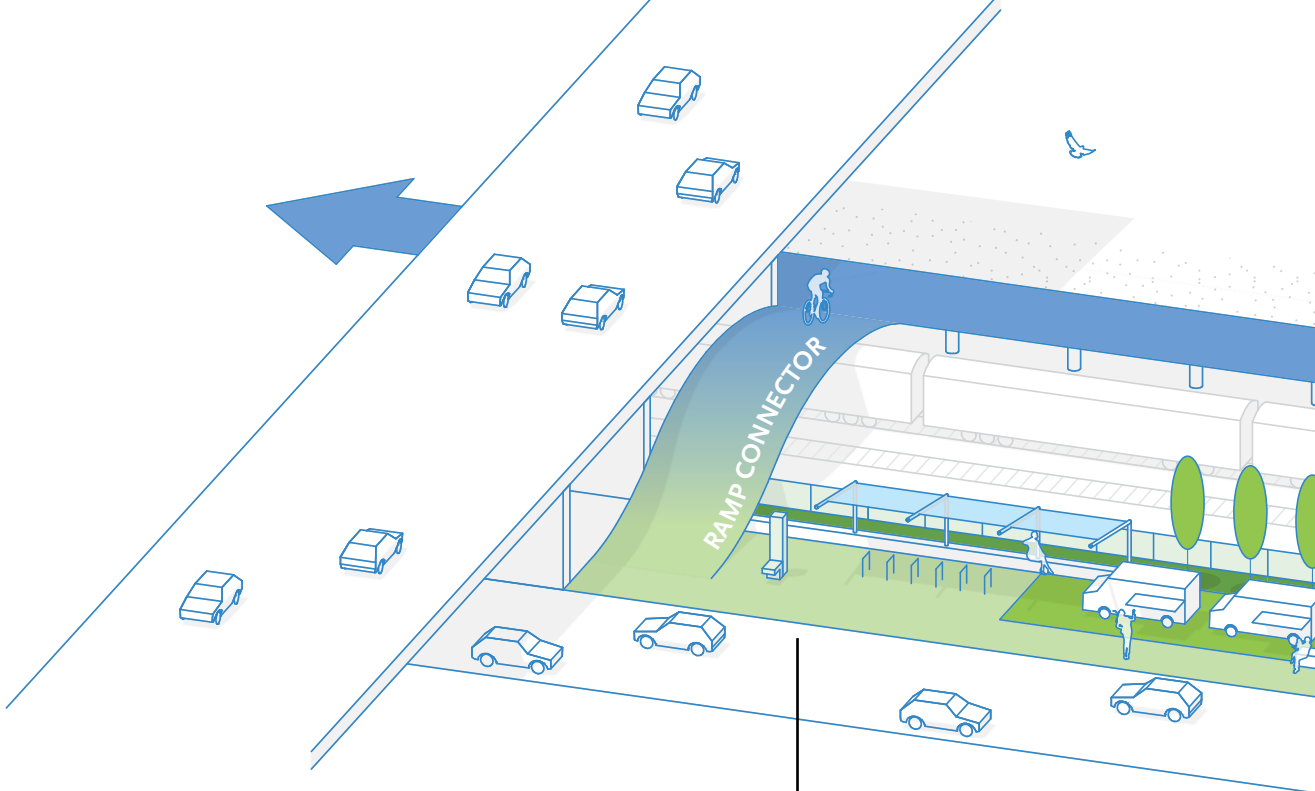

What Are Access Opportunities?

Access opportunities serve as the transition between the LA River Path and the communities surrounding it. Some may just provide access to the path, while others may be destinations themselves. While the size and features of access point areas may vary based on community needs, path user demand, available space, and the surrounding context, these spaces allow for placemaking opportunities along the path. Each design will feature a unique set of elements in order to provide functional, dynamic, and safe spaces (see Figure 43). Access point development may require partnerships with other agencies, nonprofit groups, or private entities, and may fall outside the scope of this project.

SMALL SITE (<500 SF) GET TO THE PATH

Metro would likely develop as part of LA River Path Project.

Access areas of 500 square feet or smaller may provide only access and basic elements for path users. Potential elements of these locations may include seating, shade structures, and water.

Figure 43. Conceptual Access Area Diagram

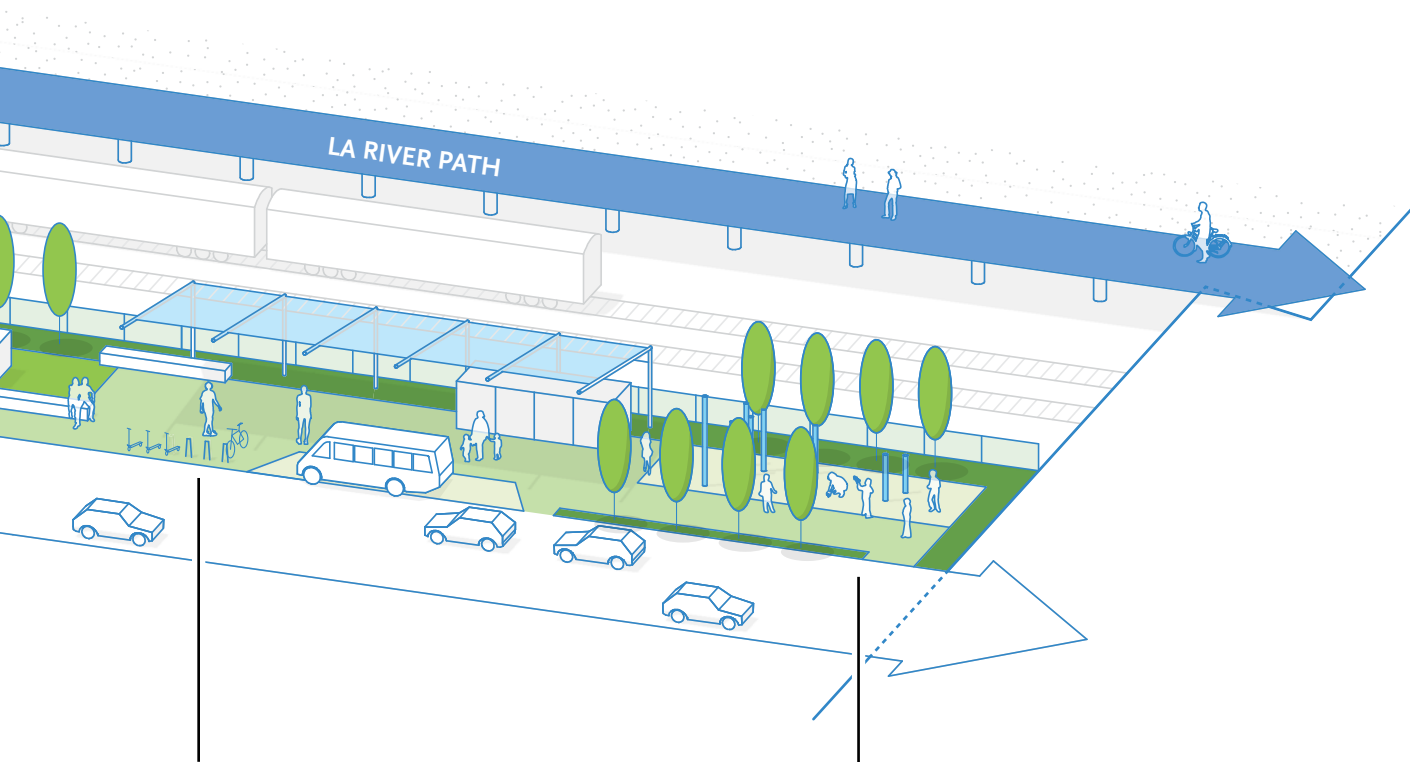

**MEDIUM SITE (500–3000 SF)
GATHER AT THE PATH**

Agency partners would help support site development and programming.

Access areas of 500 to 3,000 square feet may resemble mid-sized plazas. Small scale programming could be accommodated including seating areas, shade structures, small lawns or plazas, fitness equipment, bicycle amenities, and small landscaped areas.

**LARGE SITE (>3000 SF)
GO SOMEPLACE FUN**

Agency partners and joint development could support development and programming.

Access areas of 3,000 square feet or larger may create opportunities to add public space to communities. Large-scale active and passive programming could be accommodated in a single location, including restrooms, small play fields, large picnic shelters, event space, playgrounds, and community gardens.

Access Assessment

Access was repeatedly reported to be a key priority for community members. Access point location and design are opportunities to integrate the themes that emerged from the early engagement events:

- **Create a great user experience**
- **Make the path safe**
- **A desire to use the path for recreation and commuting**
- **Provide access to transit, jobs, and key destinations**

To determine where access opportunities exist along the project corridor, the project team developed a list of criteria, based on existing conditions and technical understanding of the corridor, to assess the feasibility of various locations. Over 40 potential feasible access points were identified across the project corridor (Map 22). Opportunities are located along both the east and west banks of the project corridor. The preliminary locations were reviewed to ensure they met one or more of the following criteria to determine their feasibility:

- Located at an arterial bridge
- Located at a low-volume roadway or street end
- Provide key connections to residential areas
- Provide key connections to major destinations
- Adjacent to current or future redevelopments
- Adjacent to existing/proposed parks and open spaces
- Availability of underutilized parcels

Design of these areas should serve the following objectives:

Access: provide direct and legible access to the LA River Path.

Design & Aesthetics: create a visually engaging design that responds to the aesthetics of both the LA River Path and community vision.

Maintenance & Emergency Access: provide ease of maintenance as well as maintenance and emergency vehicle access to the LA River Path, as needed.

In addition to these primary objectives, the design of access point areas will also seek to accommodate a range of programming opportunities to respond to community needs.

The feasible access points listed in Map 22 were presented to the community in January and February 2019, both at in-person events and through an online webtool. Community members were given the opportunity to rank their preferred access points. These preferences were taken into account during the alternative evaluation process described in Chapter 9, and were incorporated into the three recommended path alternatives described in Chapter 10.

The final path access points will be determined by the iterative alternative selection process during the environmental review phase of this project, and informed by ongoing community and stakeholder input.¹

¹ Metro. 2019. *LA River Path Project Access and Accessibility Assessment*. Los Angeles, CA.

Map 22. Potential Access

○ Access Opportunity

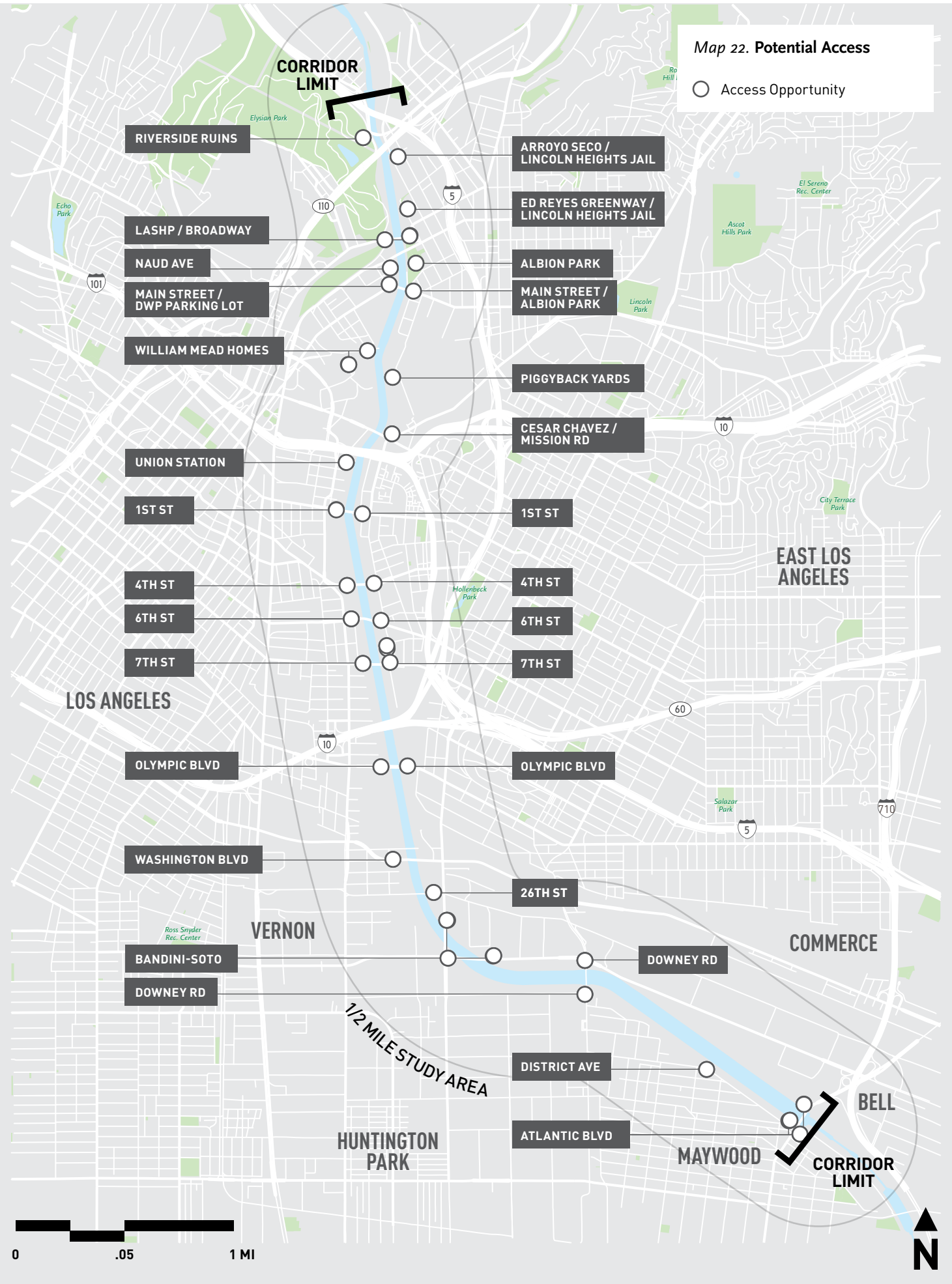

Access Elements

Each scale of access opportunity offers a unique set of possible amenities and potential programming. Each access point may be programmed according to the site-specific opportunities and constraints, with input from nearby communities. Table 6 provides an initial range of potential opportunities that could be considered at each scale. This list is not exhaustive but serves as a starting point for programming for each site. During the early engagement activities focused on mission and goals (see Chapter 3), 58% of the input received was related to user experience. This included a desire for elements that could be integrated into access points, such as shade, seating areas, water fountains, restrooms, and landscaping. Potential amenities included at access points will be informed by additional community input, available budget, and other factors.

Table 6. Amenities and Landscape

		SMALL <500SF	MEDIUM 500–3000 SF	LARGE >3000 SF
POTENTIAL AMENITIES	ELEMENT			
	Emergency Call Box	●	●	●
	Interpretive Signage	●	●	●
	Bicycle tool stand/pump	●	●	●
	Trash Receptacles	●	●	●
	Drinking Fountains	●	●	●
	Benches	●	●	●
	Shade Structure	●	●	●
	Lighting	●	●	●
	Mobility Hub		●	●
	Movable Seating		●	●
	Terraced Seating		●	●
	Fitness Equipment		●	●
	Picnic Shelter/Grills		●	●
	Viewing Platform		●	●
	Splashpad		●	●
	Game Tables		●	●
	Picnic Tables		●	●
	Habitat/Ecological Area		●	●
	Community Garden		●	●
	Bicycle Racks		●	●
	Wayfinding Kiosk		●	●
	Live Tracker		●	●
	Playground		●	●
	Basketball Court			●
	Food Trucks/Hand Carts			●
	Outdoor Education			●
	Coffee Kiosk/Commerce			●
	Amphitheater/Movie Wall			●
	Water Feature			●
	Bathrooms			●
	Transit Kiosk/Ticketing Kiosk			●
Tennis/Handball Wall			●	
Pavilion			●	
Development			●	
Parking			●	
Skate/BMX Park			●	
Small Soccer Field			●	
POTENTIAL LANDSCAPE	Shade Trees		●	●
	Ornamental Trees	●	●	●
	Shrubs and Ground Cover	●	●	●
	Vines/Green Screen	●	●	●
	Bioretention Swale		●	●

Mobility Hubs

Mobility hubs are a collection of transportation-oriented elements that make it easier to access the shared and active mobility network. The key elements can be mixed and matched to create a mobility hub that is customized for each access point. Mobility hubs are places where different modes, such as walking, bicycling, transit, and shared and micro mobility services, come together to provide a suite of transportation options for people. Bicycle share, scooter share, car share, public transit, wayfinding, and green infrastructure may all be included in mobility hubs. Some access points may provide an appropriate location for mobility hubs as places where the LA River Path provides a connection to community needs. Providing additional mobility services at strategic access points will increase the connectivity and mobility options of path users, who may combine transit, active modes, and micro mobility options found at the mobility hubs to create seamless transportation connections throughout the city.

The City of Los Angeles' Mobility Hubs program states "Supporting first–last mile solutions by providing multimodal transportation services and activities around transit stations to maximize connectivity and access for transit riders is the main goal of Mobility Hubs." The Mobility Hubs program is an extension of the Mobility Plan 2035 and is a coordinated effort with the City of Los Angeles, LADOT, and Metro.

Along the LA River Path, there are strategic locations where mobility hubs would provide important connections to the surrounding network and destinations. By providing a robust set of transportation options at mobility hubs, the unique and complex mobility needs of path users can be met, increasing the connectivity of the system and the destinations that can be reached by non single occupancy vehicles.

Amenities that may be found at a mobility hub include, but are not limited to:

- Adequate bus stop and layover zones
- Transit shelters with real-time arrival information
- Bicycle share stations
- Scooter-share or other micromobility options
- Car share facilities
- Taxi or ride hailing waiting/call areas
- Wi-Fi service
- Bicycle storage & repair facilities
- Retail
- Open space

By providing a robust array of options at mobility hubs, a variety of different needs can be accommodated, greatly increasing the number of destinations reachable by transit.

COMMUNITY CONNECTION OPPORTUNITIES

Network Connections

The LA River Path will connect to the bicycle and pedestrian on-street networks via access points. While the bicycle and pedestrian networks connect to a variety of transit facilities and community destinations, there are currently gaps between the future LA River Path and the existing on-street networks.

To assist in the planning process, the project team has highlighted pedestrian and bicycle improvements that provide key community connections to the LA River Path (see Map 23). The corridors highlighted include road crossings as well as local streets parallel to the river. Some of these projects have been previously identified in existing planning documents, including the Los Angeles Mobility Plan 2035, the Metro Active Transportation Strategic Plan (2016), the Vernon Bicycle Master Plan (2017), and the Blue Line First/Last Mile Plan (2018).

Ongoing coordination between the governing jurisdictions and the LA River Path project development team will inform the development of path alignments and access points throughout the design process. Additionally, ongoing engagement with community based organizations, to gather information on local needs, will help further prioritize this list of improvements (see Table 7).

The Experience for People Walking and Bicycling

As a facility that is easy to use and physically separated from automobile traffic, the LA River Path aims to accommodate and welcome users of all ages and abilities. Similarly, the corridors highlighted as opportunities for community connections should provide mobility and a low-stress experience for a wide range of users. For people walking, this may include a sidewalk that feels comfortable with lighting and shade. For bicyclists, this may include some form of physical separation from automobiles, or corridors with low traffic speeds and volumes where street space is shared.

Safety was highlighted as one of the public's top priorities for this project, with 28% of respondents saying safety was their top concern. Safe walking and bicycling connections from adjacent neighborhoods to the path are an important aspect of the overall user experience of the LA River Path.

Map 23. Community Connection Opportunities

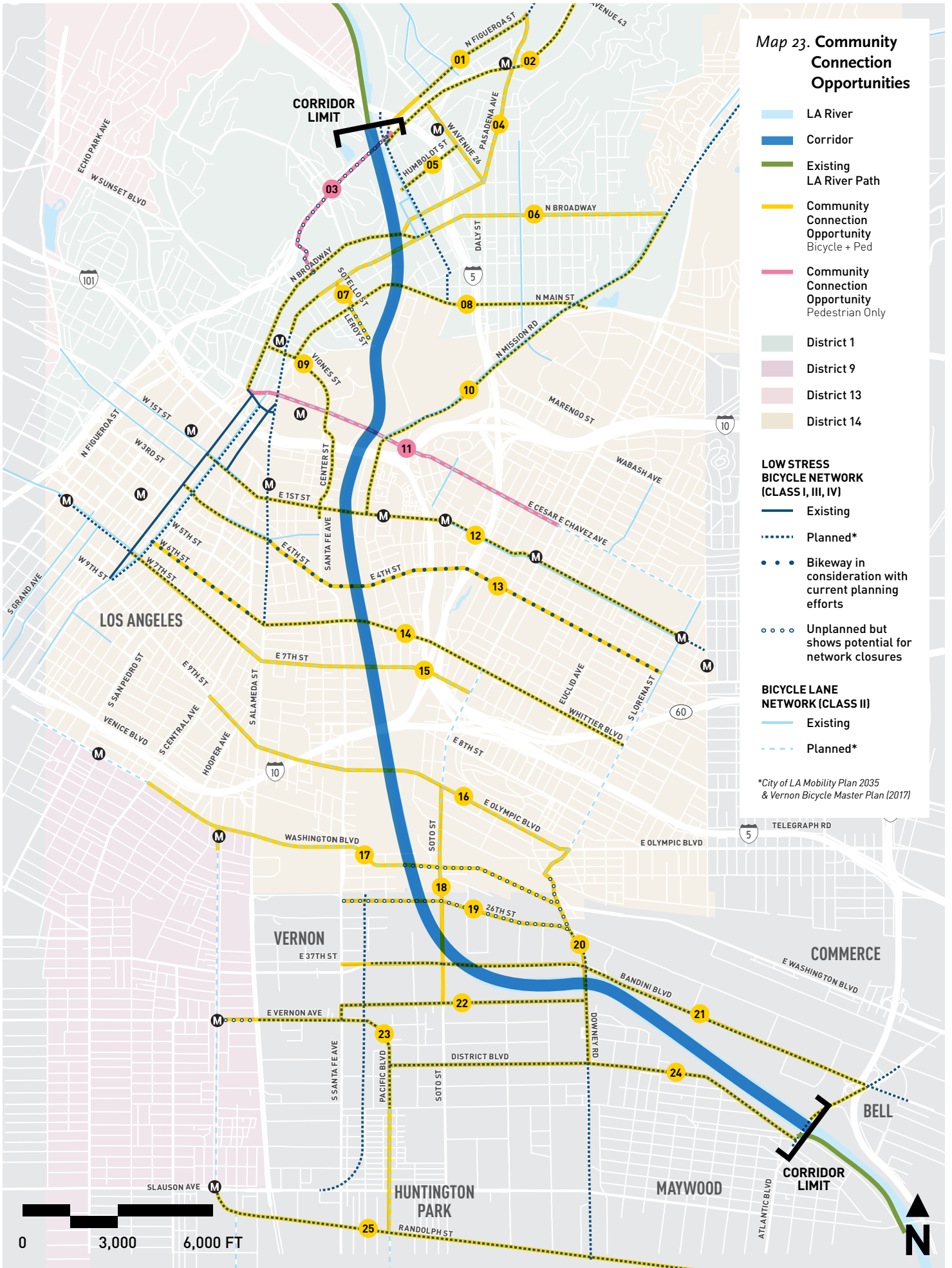

Table 7. Community Connection Opportunities

LEGEND

Community Connection Opportunity

- Bicycle and Pedestrian
- Pedestrian Only

Bicycle Network Connectivity Rating

This rating counts how many instances the proposed connection crosses or overlaps with existing and planned bicycle facilities (from the Mobility Pan, Metro Active Transportation Strategic Plan, Los Angeles County Bike Plan, and the Vernon Bicycle Master Plan).

Low Medium High

Pedestrian Network Connectivity Rating

Low / Medium / High

This rating counts how many instances the proposed connection crosses or overlaps with either the “Neighborhood Enhanced Network” or the “Pedestrian Arterial Network” from the Mobility Plan 2035.

Low Medium High

Transit Connectivity Rating























Low / Medium / High





















This rating counts how many rail or bus lines the corridor potentially gives access to.





















Low Medium High

Improvements included in this table include those planned, considered, and those not yet studied.

	NAME	KEY DESTINATIONS SERVED	BIKE NETWORK CONNECTIONS	PED NETWORK CONNECTIONS	TRANSIT ACCESS
01	NORTH FIGUEROA STREET	Confluence Park, Florence Nightingale Middle School, Kingdom Hall of Jehovah’s Witnesses, Greayer’s Oak Park			
02	PROPOSED ARROYO SECO BICYCLE PATH	Northeast Los Angeles Communities (Mt Washington, Highland Park, Montecito Heights), Heritage Square Museum, Lumis Home			
03	ARROYO SECO PATHWAY	Dodger Stadium, Elysian Park, Solano Canyon, Solano Elementary School			
04	N BROADWAY/PASADENA AVENUE	Chinatown Business District, Cathedral High School, St. Peter’s Italian Catholic Church, State Historic Park Residential Commercial Development, Elysian Park/ Radio Hill Gardens, Solano Canyon, Dodger Stadium, YoungNak Presbyterian Church, Downey Recreation Center			

	NAME	KEY DESTINATIONS SERVED	BIKE NETWORK CONNECTIONS	PED NETWORK CONNECTIONS	TRANSIT ACCESS
05	HUMBOLT STREET/ AVENUE 26	Chinatown Gold Line Station, Los Angeles State Historic Park, THMC - Church, Metabolic Studio/LADWP Recycled Water Project, Downey Recreation Center,	 	 	  
06	N SPRING STREET/N BROADWAY	Chinatown Gold Line Station, Los Angeles State Historic Park, THMC–Church, Metabolic Studio/LADWP Recycled Water Project, Downey Recreation Center	 	 	  
07	SOTELLO/ LEROY STREET	Los Angeles State Historic Park	  	 	
08	N MAIN STREET	The California Endowment, Cathay LA Inc, Excel Charter Academy, The Brewery Lofts, Our Lady Help of Christians School, Droplabs Coworking Space	  	  	  
09	SANTA FE/ CENTER STREET/ VIGNES STREET	Homeboy Industries, Metro ESOC Building, Citizens Warehouse/Pickle Works Building, LINK Union Station, Metro Headquarters	  		  
10	N MISSION ROAD	Mission Village, Rescare Northeast Work Source, Lincoln Park Senior Citizens Center, Amistad Preschool, Academy of Environmental & Social Policy High School, East Los Angeles Skills Center, Lincoln Park Skatepark, Lincoln Park DMV, Plaza De La Raza, USC Keck Hospital, Los Angeles County Public Work, Los Angeles County Hospital, Harbor UCLA Medical Center, Piggyback Yards, Aliso Village Apartments	  		  
11	CESAR CHAVEZ AVENUE	Cesar Chavez Business District, Los Angeles Fire Station, White Memorial Church, Church of San Antonio de Padua, Aliso Triangle, San Antonio de Padua Academy Preschool, LAPD Hooper, Metro HQ, Union Station, US Post Office, Ramón C. Cortines School of Visual and Performing Arts	  	  	  

	NAME	KEY DESTINATIONS SERVED	BIKE NETWORK CONNECTIONS	PED NETWORK CONNECTIONS	TRANSIT ACCESS
12	E 1ST STREET	Soto/Aliso/Mariachi Plaza Gold Line Stations, Lani Vest Pocket Park, LAPD Station, Hollenbeck Youth Center, Iglesia Evangelica De Jesucristo, Libros Schmibros Lending Library, Utah Street Elementary School, Los Palomas Apartments, Nishi Hongwanji Child Development Center, Nishi Hongwanji Buddhist Temple, Japanese American National Museum, Koyasan Buddhist Temple, Japanese Village Plaza, Caltrans District 7, LADOT HQ, City Hall, Parker Center, LAPD HQ			
13	E 4TH STREET	Aliso Pico Recreation Center, Hollenbeck Park			
14	E 6TH STREET/ WHITTIER BOULEVARD	Metro Div 20 MOW Development, 670 Mesquit Development, 6th Street Bridge and PARC			
15	E 7TH STREET	Bishop Mora Salesian High School			
16	OLYMPIC BOULEVARD	Sears Building Redevelopment, Lou Costello Youth Center, Wyvernwood Garden Apartments, Christopher Dena Elementary School			
17	WASHINGTON BOULEVARD	<i>Note: Class II Bicycle Lane is only proposed west of the river. There aren't key destinations or existing bus stops, but it does come into contact with Metro's Rail to River bicycle path.</i>			
18	SOTO STREET	Proposed Vernon Triangle Park, LDS Employment Resource Services <i>Note: Heavy industrial site</i>			

	NAME	KEY DESTINATIONS SERVED	BIKE NETWORK CONNECTIONS	PED NETWORK CONNECTIONS	TRANSIT ACCESS
19	26TH STREET	<i>Note: Industrial and isolated location but has many bicycle network connections to Class I bicycle lanes.</i>			
20	DOWNEY ROAD	<i>Note: Heavy industrial site</i>			
21	BANDINI BOULEVARD	Proposed Vernon Triangle Park <i>Note: Heavy industrial site. Community connector ends near the 710 Freeway. Metro has approved expanding the 710 Freeway</i>			
22	E VERNON AVENUE	Vernon City School, Vernon Police Department			
23	PACIFIC BOULEVARD	Aspire Pacific Academy School, Pacific Boulevard School, Community Hospital of Huntington Park, Commercial Plaza			
24	DISTRICT BOULEVARD	<i>Note: Heavy industrial site</i>			
25	RAIL TO RIVER CORRIDOR	Lillian Street Elementary School, Raul R. Perez Memorial Park, Pacific Boulevard Commercial Boulevard, San Antonio Continuation School, The Church of Jesus Christ of Latter-day Saints, United Methodist Church			



09

ALTERNATIVE EVALUATION PROCESS

Why is this important?

The LA River Path project corridor is complex and multifaceted, and could feature a variety of routes and access points, collectively known as alternatives.



How does it apply to the LA River Path?

It is important to understand and evaluate the alternative options in order to arrive at a design solution that meets the mission statement of the project and benefits the community and future path users.

Chapter 9 outlines the process used for identifying and analyzing path alternatives.

ALTERNATIVE EVALUATION PROCESS

Overview of the Evaluation Process

There are dozens of unique alignment options that could be considered for the LA River Path, each with different combinations of access points, river crossings, and path types. While in some locations there may only be a few options due to existing constraints, most areas of the corridor have numerous permutations.

An evaluation process was developed and informed by feedback from the community. It was used to create, filter, and revise alignment options and to inform the selection of three path alternatives to be studied during the environmental design and clearance phase of the project (Figure 44).

The project team used the information developed during the existing conditions assessments to determine a range of feasible alignment options, including potential access point opportunities and path types for linear alignments.

To ensure the project would best address community needs and desires, the potential alternatives were screened against specific evaluation criteria; these evaluation criteria were developed based on community input to the six project goals received during Fall 2018 engagement activities. These screenings helped identify five potential alternatives that responded best to the project goals.

The project team presented feasible access points and path types to the community in January and February 2019. The feedback received was used to analyze how well each option responded to community preferences.

The five potential alternatives were further refined based on community input and underwent a final evaluation criteria screening, as detailed at the end of this chapter. Each step of the evaluation process is further detailed in this chapter (9).

Following the final evaluation criteria screening, the three path alternatives that responded best to both the evaluation criteria and community input were ultimately presented to the community for their feedback in May 2019. Based on the positive response received, these three path alternatives are recommended to move forward to environmental review. They are detailed in Chapter 10.

Figure 44. Alternative Evaluation Process

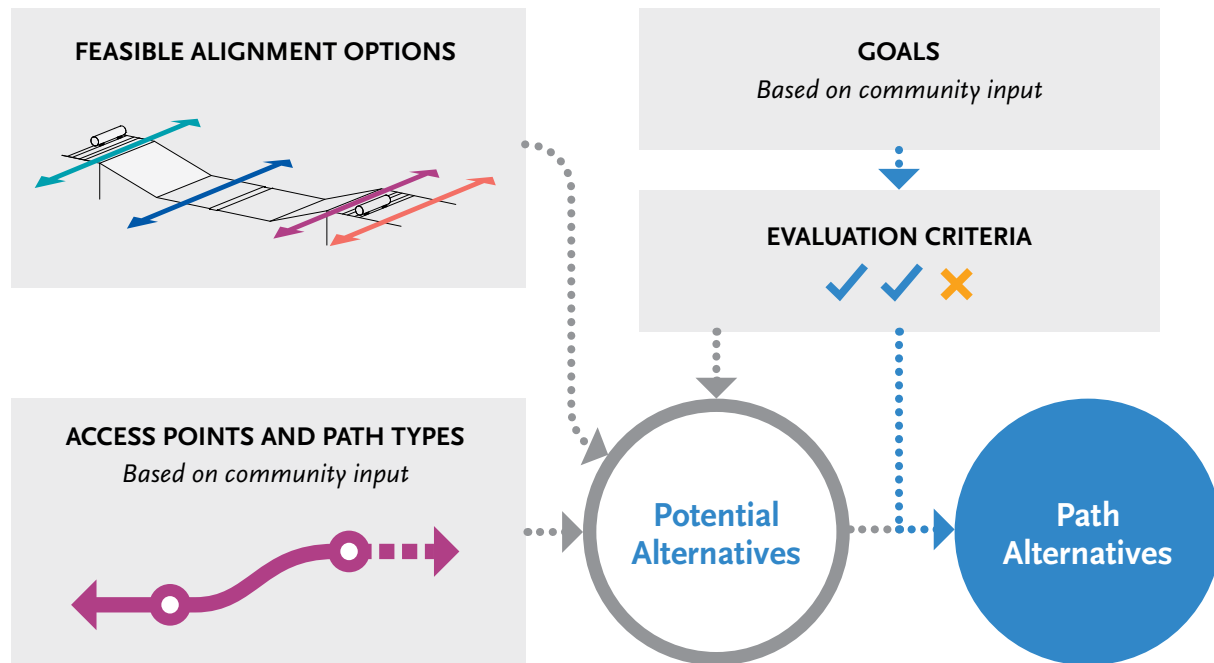

FEASIBLE ALIGNMENT OPTIONS

Feasible Alignment Options

A series of steps was undertaken as part of the analysis process. The objective of the first step was to develop preliminary yet feasible alignment options.* In subsequent steps, these feasible alignment options were refined and screened against the evaluation criteria to identify five potential alternatives and ultimately three path alternatives.

The project team began by studying the corridor and brainstorming a wide range of possible ways for the path to close the existing corridor gap. The team identified functional conceptual options for the horizontal configuration, path types, and access points for the project. The intent of this step was to thoroughly explore the many different ways a path could weave through the corridor.

All feasible alignment options were required to fulfill the project mission statement, as identified in Chapter 1. To ensure this, the project team screened the wide range of design variations against a set of fatal flaw criteria, baseline requirements without which the path cannot be successfully designed or constructed. The purpose of these criteria were to remove design options from consideration if it was apparent from a technical perspective that the options would not fulfill the mission statement of the project. There were five fatal flaw criteria used for the analysis:

ACCESSIBLE, CONSISTENT, AND SAFE:

The path is accessible, consistent, and safe for path users of all ages and abilities.

FLOOD PROTECTION:

The path must not impede the existing hydrological function of the Los Angeles River corridor.

HISTORIC RESOURCE IMPACTS:

The path avoids significant impacts to historic resources.

PERMITTING AND CONSTRUCTABILITY:

The path can be permitted and constructed without major delay or complexity.

COST:

The path can be constructed on budget based on preliminary cost estimate ranges.

*These alignment options were only considered feasible in response to existing corridor conditions and a preliminary understanding of permitting and constructability requirements. A determination of what is constructable is subject to additional design, review, and approval that will take place in a later phase of the project.

ACCESSIBLE, CONSISTENT, AND SAFE

The path needs to be accessible. The constraints of the Los Angeles River corridor require the path to periodically ramp over and under bridges and rail lines. Across the eight miles, the alignment options feature grades that meet ADA standards or exceeds them where feasible to maximize user experience for all ages and abilities. See Chapter 6 Path Design for additional information on path design elements including slopes and grade.

The path needs to be consistent and predictable. Changes in grade and direction are minimized in order to maintain sense of orientation and continuity of experience. Access points are spaced along the alignments to ensure a consistent ability to get both on and off the path as needed.

The path needs to be safe and make path users feel secure. Alignment options with path locations that are isolated from view for extended distances and bridges that elevate exceedingly high above the ground were not considered because they create conditions that are unsafe or are perceived as unsafe. The alignments provide options that separate path users from all rail and vehicular traffic. Where possible, access points are located to connect to the existing or planned on-street bicycle network and low-volume roadways.

FLOOD PROTECTION

The path must not impede the existing hydrological function of the Los Angeles River corridor. It is important to maintain flood protection for public safety, to protect the neighborhoods surrounding the Los Angeles River from flooding, and to protect the public from flood waters.

The alignment options were designed to minimize impacts to the existing channel. Specific attention was given to avoiding impacts in freeboard deficient areas.

Where possible, preference was given to alignment options that utilized the top-of-bank areas without impacting the existing channel wall. Paths in locations that are consistently underwater during low flow periods were not considered. An example would be a bottom-of-channel path at Redondo Junction, where the rectangular channel has wall-to-wall flow year-round. Consideration was given to avoiding impacts to existing drainage outlets into the river.

Crossings were carefully located to minimize impacts as well. Long-span crossings that would require numerous piers were generally avoided and locations that allowed for short-spans were preferred. Consideration was given to crossing locations that required no piers in the channel or that could place piers in the shadow of existing bridge piers.

HISTORIC RESOURCE IMPACTS

The path avoids significant impacts to historic resources.

The Los Angeles River features numerous existing bridges that are considered historic resources. A “historic resource” is a property that has been listed in or found eligible for listing in a national or state historic register, designated as a local landmark, either individually or as a contributor to a historic district, or has been identified in a historic resources survey.

All alignment options were designed to minimize visual impacts to historic bridges. Preference was given to river crossings that are not adjacent to a historic bridge. The alignment options generally pass underneath elevated historic bridges as close to top-of-bank as possible, and avoid passing over the middle of at-grade historic bridges. The alignment options considered views between bridges, views from the bridges to the river channel, and views from adjacent public spaces towards the bridges.

Where possible, access points avoid directly landing on historic bridges, opting for adjacent low-volume roadways or open spaces. For access points where historic bridge impacts may be required, consideration was given to landing locations that complement the historic architecture.

Not all historic visual impacts are considered negative. Thought was given to locations where the path and potential structures can be used to complement, frame, provide new view points, or uplift historic bridge architecture.

PERMITTING AND CONSTRUCTABILITY

The path can be permitted and constructed without major delay or complexity.

The path needs to be approved by and coordinated with a variety of different agencies as identified in Table 3 “Major Permitting” on page 28.

The alignment options consider the regulations of public and private rail owners, and account for setbacks from and clearances over rail lines. Setbacks from utilities influence both path location and path type. At grade and cantilever path types were only considered in locations with enough top of bank space to both construct the path and meet setback requirements. Access ramps over rail were only considered in locations where it is feasible to ramp over vertical clearances.

The alignment options consider the regulations of overhead utility operators. All alignments account for setbacks from utility wires, and avoid utility towers where possible.

The alignment options consider the regulations of USACE, and minimize impacts to the existing channel. Long span crossings and piers in the channel are minimized, and piers are located in locations that have low impacts to hydrology.

The alignment options minimize impacts to private and rail properties. Preference was given to access points that are located on public property and that minimize the number of rail lines that the path would need to ramp over.

COST

The alignment options were guided by preliminary cost estimates and cost trade-offs.

Preliminary cost estimates included hard costs (material, equipment, labor, property acquisition, contingency), soft costs (consultant contracts, project administration, construction management), and escalation (increase in the cost of a project over time).

Each alignment option balances cost trade-offs for three design variables: linear alignment, river crossings, and access points.

The linear alignment, or path type costs are driven by the extent of more costly structural options compared to less costly at-grade options. Structural options typically provide more flexibility in design and have fewer impacts to the existing channel.

River crossing costs are driven by the quantity of crossings and the complexity of individual crossings. Long spans that require custom designs are a magnitude more expensive than short spans that cross the river perpendicularly.

Access point costs are driven by the quantity and combination of access points. The least costly access points can be accessed at-grade directly from the path while the most costly access points require ramping up and over adjacent rail lines.

The cost ranges for the three top-performing alternatives can be found in Chapter 10.

Feasible Alignment Outcomes

The process of identifying feasible alignment options that met the fatal flaw criteria enabled the project team to identify and simplify options into general alignment locations throughout the corridor. For the purposes of this preliminary analysis, “feasible” referred only to what was considered possible given the existing corridor conditions and preliminary understanding of constructability, permitting, and costs. A determination of what is feasible from a permitting and constructability standpoint will be subject to additional detailed design, reviews, and approvals in a later phase of the project.

Four general alignment location options were identified through this process as shown in Figure 45: west bank, bottom-of-channel, east bank, and east side (not directly adjacent to the river channel). A west side alignment (not directly adjacent to the river channel) was not considered due to existing constraints on the west side of the river.

Figure 45. Alignment Locations

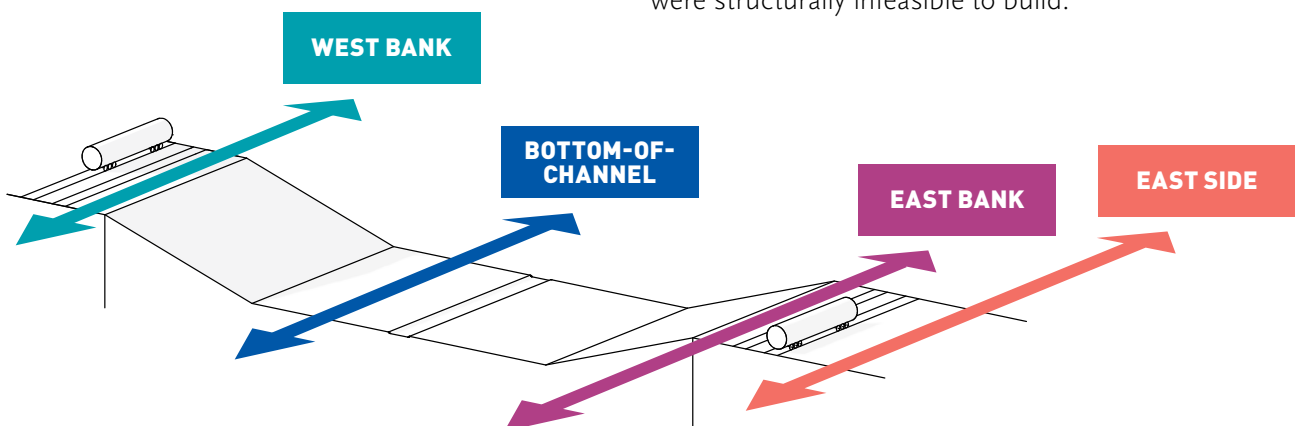







For most of the river corridor, the physical conditions would allow for a west bank, east bank, and bottom-of-channel option.

Map 24 shows the possible alignment locations and access opportunities. Bottom-of-channel was not an option for portions of the Los Angeles River with a rectangular channel, year-round standing water, and freeboard deficiencies, which includes the areas north of Main Street and between Redondo Junction and Bandini Boulevard.

The area north of Albion Park has an east side alignment available. The east side alignment, as opposed to the east bank alignment, is separated from the channel by active rail and includes both on-street and at-grade back-of-rail options. Meanwhile, at Redondo Junction, physical and hydrological constraints only allow for a west bank option.

A broad range of access opportunities are feasible (see Access Assessment, Chapter 8 for further information). Most access point locations that were not considered had no suitable roadway connections or were structurally infeasible to build.

Map 24. Alignment and Access Opportunities

-  Existing Path
-  Potential Access Point
-  West Bank Alignment
-  Bottom-of-Channel Alignment
-  East Bank Alignment
-  East Side Alignment



Representative Photographs of Corridor Conditions

The following photographs provide visual examples of some of the corridor complexities that influenced the development of feasible alignments.

Photo 115 highlights the east bank conditions (looking upstream) between the Metro Gold Line and Broadway, with opportunities for a back-of-rail and adjacent to channel path.

Photo 116 shows the top-of-bank constraints between 1st and 4th Streets along the west bank (looking downstream), with utility towers, narrow rail setbacks, and bridge abutments.

West bank conditions south of Redondo Junction (looking downstream) are seen in photo 117, with industrial businesses and structures extending up to the edge of the channel wall.

Photo 118 highlights the east bank conditions between Atlantic Boulevard and Downey Road (looking upstream), with existing maintenance road and rail setback.



115. Gold Line and Broadway

116. 1st Street and 4th Street

117. South of Redondo Junction

118. Atlantic Boulevard and Downey Road





COMMUNITY FEEDBACK ON PATH TYPES AND ACCESS POINTS

Following the community input on mission and goals discussed in Chapter 3, the feasible access points and path types were brought to the community in January and February 2019. Community members provided feedback on path types and access points using an online webtool and in-person at community meetings. Community open house meetings were held in Cypress Park, Boyle Heights, the Arts District, and at a “Coffee with the Principal” meeting in the City of Maywood. Overall, 1,912 online survey responses and nearly 1,000 in-person comments were received.

Access points and path type preferences identified by the community were used to develop, evaluate, and refine the potential alternative options. Ultimately, the community preferences for specific access points and path types were weighed against cost trade-offs and the project goals.

PREFERRED ACCESS POINTS

Community members were asked to select their preferred access points across three reaches of the river (north, central, south) and identify the reasons why these access points were selected. Figure 46 shows the combined feedback from the online webtool and in-person meetings.

Los Angeles State Historic Park/Main Street was consistently ranked as the top preferred access point in the north reach based on the webtool and in-person meeting feedback. Arroyo Seco was the second most highly ranked access point in the north reach, indicating that connections to parks and open space are a key priority for community members.

Preferences for access point locations varied more in the central reach. At the community meetings, Union Station was considered a priority access point, selected either first or second by participants. Attendees of the Boyle Heights and Arts District community meetings prioritized access points closest to their neighborhood. In addition to Union Station, at the Boyle Heights meeting, Mission Road/Cesar Chavez Avenue, 1st Street East, and 4th Street East were the top selected access points. At the Arts District meeting, 6th Street Tunnel, 7th Street West, and 1st Street West were the top selected access points. The most commonly selected access points for participants from the webtool were 1st Street West, Union Station, and 7th Street West.

In the south reach, Washington Boulevard was the most highly selected access point for participants from the webtool, Boyle Heights, Arts District, and Cypress Park meetings, but received no interest from attendees of the Maywood Elementary Coffee with the Principal meeting—those who live in the closest vicinity of the access point. The attendees at the Maywood elementary meeting prioritized access at Atlantic Boulevard and District Avenue, closest to their homes.

REASONS BEHIND ACCESS POINT PREFERENCES

Community members also provided comments for why they chose their preferred access points. On the webtool, people could select from a multiple choice list (to exercise or for recreation; to commute to work/school; to run errands or

visit family/friends; or write in comments). For all access points, the majority of respondents selected “to exercise or for recreation” as the top reason for their selection. The Union Station access point had the greatest number of respondents stating they would use the access point “to commute to work/school.”

The write in comments provided additional feedback on why various access points were important to people. Some examples include:

Los Angeles State Historic Park/Main Street:

“Connection with local parks/ rec areas is crucial”

Union Station:

“Access to regional transit hub enables access for all”

Mission Rd/Cesar Chavez:

“All uses served: cultural, work, and pleasure. This is also the gateway to the ‘east side.’”

6th Street Tunnel:

“It will be nice to have good connections to the new viaduct and parks in the area, as well as the heart of the Arts District.”

Downey Road:

“Nice to have an entrance without having to go through all the industrial parks and railroad crossings further down”

Figure 46. Preferred Access Points by Segment

NORTH

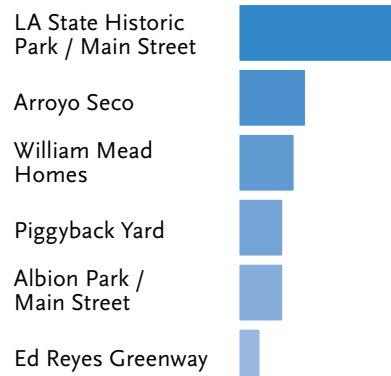

CENTRAL

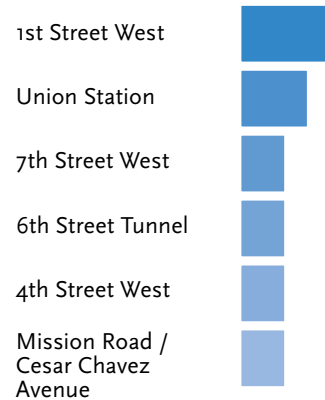

SOUTH

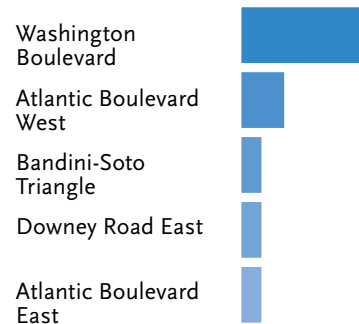



Figure 47. **Elevated**

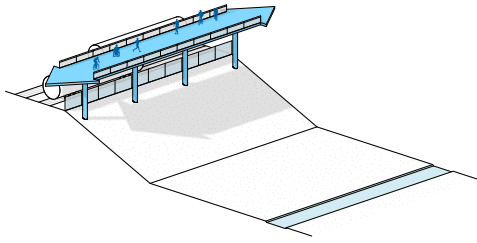

Figure 48. **Top-of-Bank**

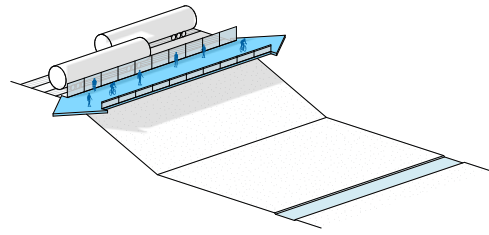

Figure 49. **Incised**

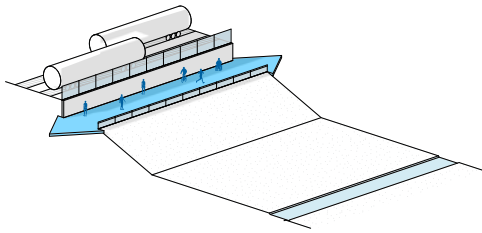
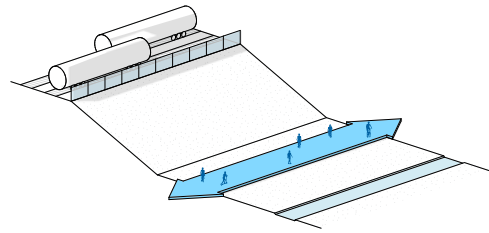

Figure 50. **Bottom-of-Channel**



PATH TYPES

A number of path types will be necessary to allow the LA River Path to navigate the various corridor constraints (see Chapter 6, Path Design for additional descriptions of path types). Although each alternative is made up of several path types, it is important to understand the community's preferences because each path type has trade-offs.

Community members were asked to select their preferred path types and identify the reasons why by assigning points to the trade-offs they value most. There were five trade-offs:

1. Path reliability (degree to which the path would potentially be closed or open year-round)
2. Street access (long ramp to street or direct access to street)
3. The potential for adding shade, landscape, and lighting or not
4. The degree of enclosure/exposure
5. The potential for opportunities for peace and quiet

Figure 51. Community Preferences for Path Types from Community Meetings and Webtool, January and February 2019

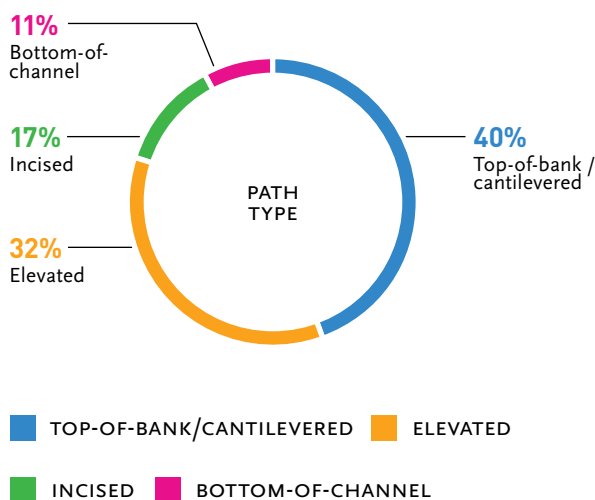
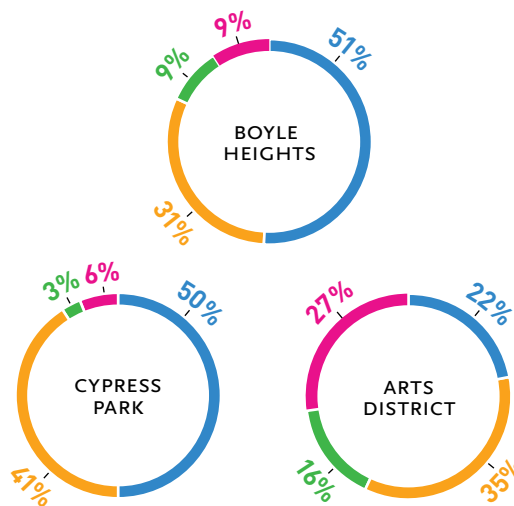

Figure 52. Community Preference for Path Types by Individual Community Meetings, January and February 2019



Seventy-two percent of respondents selected a path type (top-of-bank or elevated) that was open year-round (see Figure 51). Reliability of the path was the most important reason behind respondents' path type selection, followed by providing a more direct connection to adjacent streets, and having the potential for amenities such as shade and lighting.

Twenty-eight percent of respondents selected an incised or bottom-of-channel path type. The respondents who selected the bottom-of-channel path type largely did so for peace and quiet from the surrounding roadways, rail lines, and industry. The reasons behind community members'

selection for the incised path typology were more evenly split, with respondents choosing peace and quiet and reliability.

Feedback from the community meetings generally mirrored the webtool results, with the highest percentages of responses for top-of-bank and elevated paths. The exception was at the Arts District community meeting, where bottom-of-channel was the second most popular path type, receiving 27% of the total interest. This path type was largely chosen because of its ability to provide peace and quiet and because of the perception that it would be the lowest cost option (see Figure 52).

GOAL-BASED EVALUATION CRITERIA







To understand the benefits, challenges, and relative strengths of alternatives, the project team developed a process to measure alternatives against each of the project goals. The six goals (safety, access, efficient and sustainable mobility, equity, user experience, and health) were developed early in the process by translating community and stakeholder priorities for the future path into a guiding framework for the project. Community input on goals can be found in Chapter 3.

Criteria were developed based on best practices and available data to help assess how well the alternatives fulfill the project goals. Performance metrics were developed for each criterion to indicate how the evaluation was performed. Some criteria provide performance metrics related to access points. For example, the Access goal has four criteria that measure how well an access point provides connections to employment, points of interest, services, and aligns with planned projects. Other criteria, such as reliability and travel time, related to the Efficient and Sustainable Mobility goal, are measurements of the linear alignment based on path types (see Table 8).

Most of the performance metrics are quantitative, and were assessed using a data-driven approach using available GIS and other data. An example of quantitative measures include counts, such as how many destinations are within one mile of an access point. Some performance metrics are qualitative, assessed using the professional judgment of the project team, based on their understanding of the site context, path design practices, and opportunities.

The project team conducted an initial screening of alternative options, to assess performance with respect to the criteria. The screening provided data with which to understand the alternatives and weigh trade-offs in order to develop alternatives to be evaluated further.

Table 8. Goal-Based Evaluation Criteria

GOAL	CRITERIA	RELATED TO ACCESS POINTS	RELATED TO LINEAR ALIGNMENT	QUANTITATIVE APPROACH	
	Safety	Traffic Safety	●	●	●
		Recovery and Rescue	●		●
	Access	Access to Employment	●		●
		Access to Points of Interest	●		●
		Access to Services	●		●
		Aligns with Planned Projects	●	●	
	Efficient and Sustainable Mobility	Reliability		●	●
		Safe Network Connections	●		●
		Transit Connections	●		●
		Travel Time		●	●
	Equity	Serves Disadvantaged Communities	●		●
		Access to Desired Destinations	●		●
		Serves Park-Deficient Areas	●		●
	User Experience	Perceived Safety	●	●	
		Level of Comfort		●	●
		Sound and Smell	●	●	
		Visual Experience		●	
	Health	Physical Activity	●		●
		Community Gathering Places	●		●

Approach

The following pages describe how each criterion was measured through performance metrics. Each criterion on the following pages is organized by the goal it is associated with and includes the objective of the criterion, identifies what it measures through a quantitative or qualitative metric, and provides a description of the performance metric from higher performing to lower performing. These metrics allowed the project team to evaluate alternatives that performed higher or lower against the project goals.

GOAL:**SAFETY**

Create a path that improves safety from existing conditions.

**Traffic Safety**

The path should keep users separated from traffic by providing a facility suitable for all ages and abilities.

Quantitative Metric:

Score for traffic safety based on classification of the connecting street for each access point.

HIGHER PERFORMING

Alignment is separated from vehicular traffic; access points can be reached by traveling on a low-traffic street.

Alignment is separated from vehicular traffic; some access points require traveling on a collector street.

LOWER PERFORMING

Alignment includes on-street sections; access points require travel on a primary arterial street.

Recovery and Rescue

The path should allow users to escape from flood waters, and allow emergency vehicles to reach them in the event of flood, accident, or crime.

Quantitative Metric:

Average distance between access points.

HIGHER PERFORMING

Alignment is easily accessible by frequent access points, which allow for access to and from the path (ingress and egress).

Alignment is mostly accessible, with some stretches of the path being difficult to access due to infrequent access points.

LOWER PERFORMING

Alignment is not easily accessible due to infrequent access points.

GOAL:

ACCESS

Create a path that increases access from local neighborhoods to employment centers, regional destinations, resources, and amenities, including healthcare services.



Access to Employment

The path should connect users to employment centers.

Quantitative Metric:

Quantity of jobs within a 1-mile radius of each access point.

HIGHER PERFORMING →

Alignment provides access to a high number of jobs for people walking and bicycling; access points provide convenient and easy connections to employment centers.

Alignment provides some access to jobs for people walking and bicycling but not direct routes; access points are not located near employment centers.

→ **LOWER PERFORMING**

Alignment does not provide access to jobs for people walking and bicycling; access points are not located near employment centers.

Access to Points of Interest

The path should connect users to landmarks and regionally and locally significant destinations such as schools, parks, and commercial centers.

Quantitative Metric:

Quantity of points of interest within a 1-mile radius of each access point. Points of interest identified by Los Angeles County including education and parks.

HIGHER PERFORMING →

Alignment provides easy, comfortable, and convenient access to key destinations for people walking and bicycling; access points provide direct access to destinations.

Alignment provides access to key destinations, but it is not easy or convenient; access points could be located more conveniently.

→ **LOWER PERFORMING**

Alignment does not provide easy access to key destinations for people walking and bicycling; access points are not located near key destinations.



Access to Services

The path should connect users to healthcare, healthy food or other supportive services that contribute to higher quality of life.

Quantitative Metric:

Quantity of healthcare and social services within a 1-mile radius of each access point.

HIGHER PERFORMING

Alignment is located near important services and access points provide easy and direct access to those services.

Alignment is located near important services, but they are not easily accessed using the access points.

LOWER PERFORMING

Alignment is not located near important services, making those services difficult or impossible to access from the path.

Aligns with Planned Projects

The path should coordinate with other planning, transportation, construction, and restoration projects.

Qualitative Metric:

Relative score based on proximity to planned projects and potential for synergy and coordination. Planned projects were identified by the Steering Committee, PDT and project stakeholder group.

HIGHER PERFORMING

Alignment is well coordinated and integrated with other ongoing and future projects along the corridor, helping to create a more cohesive active transportation network; access points are planned in coordination with other projects.

Alignment is somewhat coordinated with other projects; there has been some integration with other ongoing or future projects; access points have considered other projects but are not well coordinated.

LOWER PERFORMING

Alignment is not coordinated with other projects; it is unclear how this alignment will integrate with other ongoing or future projects; access points do not consider other projects.

GOAL:

EFFICIENT AND SUSTAINABLE MOBILITY

Create a path that reduces vehicle miles traveled by allowing people to walk and bicycle in a low-stress environment through and within Los Angeles County, reducing trip lengths, and expanding travel choices.



Reliability

The path should be reliably open for use, with limited occasions when path closure would be required due to high water events.

Quantitative Metric:

Score based on the extent of path and maximum depth below high water mark, as based on elevation profile of path types.

HIGHER PERFORMING →

Alignment is above the high water mark, and path closure due to high water events would be rare.

Alignment is mostly above the high water mark, but the path would occasionally need to be closed due to high water events.

→ **LOWER PERFORMING**

Alignment is located below the high water mark, and path closure due to high water events would be common.

Safe Network Connections

The path should be part of a safe and effective walking, bicycling, and rolling network.

Quantitative Metric:

Quantity of access points with an existing or planned low-stress bikeway network or priority pedestrian corridor within a 500ft radius.

HIGHER PERFORMING →

Alignment and access points are connected to low-stress bikeways and pedestrian corridors, limiting the exposure of path users to unsafe facilities.

Alignment and access points are somewhat connected to low-stress bikeways and pedestrian facilities, but path users would experience some stress when accessing the path.

→ **LOWER PERFORMING**

Alignment and access points are not connected to low-stress facilities and path users would need to travel on unsafe facilities to access the path.



Transit Connections

The path should connect people to high frequency transit.

Quantitative Metric:

Weighted score based on connections to a Metro Rail station within 1/4 mile, or BRT Line or Transit Enhanced Network within 500ft of each access point. Score is weighted to prioritize Metro Rail and BRT connections.

HIGHER PERFORMING

Access points connect the alignment to multiple high frequency transit stations, including Metro Rail; transit is very easy to access from the path.

Access points connect the alignment to transit, but it is not high frequency or rail transit and transit is difficult to access from the path.

LOWER PERFORMING

Access points do not connect the alignment to transit or transit is difficult and not close to access from the path.

Travel Time

The path should minimize travel time and be competitive with other modes of travel through the corridor.

Quantitative Metric:

Length of alignment, as measured as a direct route from north to south terminus.

HIGHER PERFORMING

Alignment is time efficient and provides the shortest segment distance for travel on the corridor.

Alignment is somewhat time efficient, although there is some out of direction travel or indirect routes.

LOWER PERFORMING

Alignment is not time efficient; path users must travel out of direction or along an indirect route.

GOAL:

EQUITY

Create a path that improves access to opportunity for historically underinvested communities, especially in low-income communities of color.



Serves Disadvantaged Communities

The path should serve and positively impact historically disadvantaged areas and low-income communities of color.

Quantitative Metric:

Presence of disadvantaged communities within a 1-mile radius of each access point.

HIGHER PERFORMING

Access points serve the highest number of disadvantaged communities; provides the greatest opportunity to positively impact communities.

Access points serve some disadvantaged communities; provides opportunity to positively impact communities.

LOWER PERFORMING

Access points do not serve disadvantaged communities; does not provide opportunities to positively impact communities.

Access to Desired Destinations

The path should connect to places that matter in people’s lives like jobs, culturally important landmarks, and destinations.

Quantitative Metric:

Quantity of desired destinations within a 1-mile radius of each access point. Desired destinations were identified by the community during community outreach events and web surveys.

HIGHER PERFORMING

Access point is near and connects to a variety of important destinations prioritized by the community.

Access point is near and connects to some important destinations that have been prioritized by the community.

LOWER PERFORMING

Access point is not near and does not connect to important destinations that have been prioritized by the community.



Serves Park-Deficient Areas

The path should provide connection to open space and parks in areas that are park-deficient.

Quantitative Metric:

Score based on level of park need at each access point. Level of park need assessed by the 2016 Los Angeles County Parks and Recreation Needs Assessment for Los Angeles and by employment density for Vernon.

HIGHER PERFORMING

Access point connects to high quality parks and/or open space, particularly in a park-deficient area.

Access point connects to parks and/or open space but the area is not park-deficient.

LOWER PERFORMING

Access point does not connect to parks and/or open space; area is not considered park-deficient.

GOAL:

USER EXPERIENCE

Create a path that feels safe, comfortable, and is activated by the people who are drawn to it, because it is a world-class transportation corridor.



Perceived Safety

Takes advantage of visibility and “eyes on the path” to convey a sense of welcome and promote user comfort.

Qualitative Metric:

Relative score based on assessment of path types, adjacent land uses, and visibility along the path and at each access point.

HIGHER PERFORMING →

Alignment is visible from multiple angles and path users would feel seen on the path; access points reinforce path perceived safety.

Alignment is somewhat visible; path users can be seen sometimes along the path; access points provide some sense of perceived safety.

→ **LOWER PERFORMING**

Alignment is not visible and path users do not perceive that this alignment provides “eyes on the path”; access points do not increase the feeling of perceived safety for path users.

Level of Comfort

Path creates an enjoyable and comfortable user experience by limiting hills and slopes along the corridor.

Quantitative Metric:

Total elevation change along path segment. Elevation change determined by path types.

HIGHER PERFORMING →

Alignment is mostly flat and has very gentle slopes that feel very comfortable to someone walking or bicycling.

Alignment is mostly flat but has some grade change that could be uncomfortable for some path users, although most people walking or bicycling would feel comfortable.

→ **LOWER PERFORMING**

Alignment is not flat and the grade change feels uncomfortable for someone walking or bicycling.



Sound and Smell

Path users should be buffered from negative sensory experiences.

Qualitative Metric:

Relative score based on proximity and extent of noise and odor pollution along the path and at each access point.

HIGHER PERFORMING

Alignment and access points are buffered from unpleasant noise and odor pollution.

Alignment and access points are exposed to some unpleasant noise and odor pollution, but it would be mitigated or relatively minor for the path user.

LOWER PERFORMING

Alignment and access points are exposed to unpleasant noise and odor pollution and there is no amount of mitigation that would remove it.

Visual Experience

The path should provide great views by creating a unique visual experience that reflects the character of Los Angeles and Vernon neighborhoods.

Qualitative Metric:

Relative score derived from assessment of path types, adjacent land uses, and viewsheds.

HIGHER PERFORMING

Alignment provides impressive and interesting vistas for path users that are unique to the LA River Path.

Alignment provides some interesting vistas but there are also locations that lack vistas or vistas are not particularly interesting or unique.

LOWER PERFORMING

Alignment does not provide opportunities for high quality vistas.

GOAL:

HEALTH

Create a path that inspires physical activity, and opportunities for healthy choices in everyday life.



Physical Activity

The path will provide a space for walking, biking, and rolling, many activities that increase a person's activity level. This metric considers whether the path provides this space in areas where children have high rates of obesity.

Quantitative Metric:

Score based on childhood obesity rate of census tract at each access point. Based on data from the Plan for a Healthy Los Angeles (2010) and data from the Los Angeles County Department of Public Health.

HIGHER PERFORMING

Access points are located where obesity rates are high and provides convenient access to the path for physical activity.

Access points provide some access to the path for areas with high childhood obesity rates, but the access isn't as direct or convenient.

LOWER PERFORMING

Access points are not located in areas where childhood obesity rates are high, making the path not accessible to those communities.



Community Gathering Places

The path should increase places for community gathering.

Quantitative Metric:

Sum of potential square footage that could be utilized for amenities and community gathering at each access point.

HIGHER PERFORMING

Access points provide space for community gatherings and amenities in an area lacking such space.

Access points may provide gathering space, although it is unclear if that type of space would be utilized or appropriate in this location.

LOWER PERFORMING

Access points would not provide gathering space due to site configurations or space; area does not need additional space.

Goal-Based Evaluation Outcomes

The evaluation criteria screening allowed the project team to compare how well alternative options responded to the project goals. Reoccurring characteristics were found amongst both high-performing and low-performing alternatives.

HIGH PERFORMING CHARACTERISTICS

Connecting Neighborhoods

Alignments that cross the river between Chinatown and Lincoln Heights as well as Arts District and Boyle Heights performed significantly better for both Equity and Access.

On average, access points in Lincoln Heights and Boyle Heights performed highest for Equity, while access points in Arts District and Chinatown performed highest for Access to jobs and points of interest. River crossings between these neighborhoods allow the alignment to maximize residents and destinations on both sides of the river.

Job Centers

Alignments that connect to major job centers performed better for the Access goal.

Major employment centers are clustered between Cesar Chavez Avenue and 6th Street and throughout Vernon. The top job centers were located at Cesar Chavez Avenue, Union Station, 1st Street, 4th Street, 6th Street, and Bandini-Soto Triangle.

Major Parks and Metro Stations

Access points that connect to Metro stations and major parks performed well with the goals of Efficient and Sustainable Mobility and Access.

Access points at Los Angeles State Historic Park and Albion Park provide both parks access and connections to Metro stations (Gold Line). Additional access points that connect to Metro stations include Ed Reyes Greenway (Gold Line), Broadway (Gold Line), Main Street (Gold Line), 1st Street (Gold Line), and Washington Street (Blue Line).

Elevated and Top-of-Bank Path Types

Elevated and top-of-bank path types performed better for the goals of Safety, Efficient Mobility, and User Experience, and were also preferred by community members (see community input on path types, pages 191–194).

Alternatives with elevated/top-of-bank path are less vulnerable to flood risk and path closure. Travel time and path grades tend to be lower, as most access points require elevating in order to ramp over rail or can be accessed directly from top-of-bank. In addition, both path types—particularly elevated—can conveniently pass over at-grade bridges. For elevated paths, there are more dramatic vistas towards downtown Los Angeles and the San Gabriel Mountains. For top-of-bank paths, higher visibility and less frequent isolation provide greater perceived safety.

LOW PERFORMING CHARACTERISTICS

Bottom-of-Channel Path

The bottom-of-channel path does not meet the goals for Safety, Access, and Sustainable and Efficient Mobility. Of the four path types, it scored lowest due to two primary factors: inherent limitations of being in the river channel and difficulty reaching access points.

Compared to the other three path types, a bottom-of-channel path does not allow users to easily escape from flood waters in the bottom of the channel and limits the ability of emergency vehicles to reach users in the event of flood. In addition, there may be greater distances between access points, potentially slowing response time in the event of injury or crime.

The bottom-of-channel path type also impacts access. A bottom-of-channel path requires significantly longer ramps to connect to access points. In locations where access requires elevating over an adjacent rail line such as at Union Station, a bottom-of-channel path would have to elevate up almost 50 feet—approximately 25 feet to go from bottom-of-channel to top-of-bank

and 25 feet to ramp from top-of-bank to the required rail overhead clearance. This would result in ramp lengths ranging from 1,000 feet (at 5% grade) to 2,000 feet (at 2.5% grade). As a result, alternatives with a bottom-of-channel path as the core through path would require approximately one additional mile of ramps as compared to alternatives that use other path types.

In addition, the bottom-of-channel path is less reliable than other path types due to risk of flood events. During rainy seasons, the path may have extended periods of closure.

Lastly, user experience would be impacted due to low visibility both in and out of the channel, which impacts perceived safety. Furthermore, the public has expressed the importance of lighting and amenities such as shade, seating, and landscaping along the path. In most instances, it is not feasible to place these types of elements in the channel due to USACE regulations and maintenance considerations. These regulations will also impact the potential amenities of incised paths as well, but will be significantly more limiting for a bottom-of-channel path.

All-West Alternative

The all-west alternative performed low with the goals of Access and Equity.

By following the west bank, the all-west alternative has limited and indirect access to Equity Focus Communities in Lincoln Heights and Boyle Heights. The alternative also limits connections to key services and points of interest on the east side, including the USC Keck Medical Complex, Albion Park, and local commercial destinations.

In order to avoid impacts to existing infrastructure along the top-of-bank, to achieve acceptable path grades, and to take advantage of public right-of-way opportunities further south, the all-west alternative is not feasible through Redondo Junction.

Mostly-East Alternative

The mostly-east alternative performed poorly with the goal of Access.

The mostly-east alternative connects to the existing paths on the west bank. It also uses the west bank through Redondo Junction, but otherwise follows the east bank of the river. This alternative provides minimal access on the west side in the Arts District and Chinatown, which impacts access to jobs and points of interest.

Screening

Using the evaluation criteria, a series of preliminary screenings were conducted for the feasible path options and access points to help identify five potential alternatives. These potential alternatives provide a range of desirable design options that respond well to the project goals and the public input regarding access points and path types.

The five potential alternatives were refined once more based on community input regarding access points, and then underwent a final evaluation criteria screening.

Table 9 is a comparison matrix of the five potential alternatives and provides a summary of how each alternative performed for each goal. The table uses the harvey ball scoring method, showing a range from the criteria meeting the goal (half circle) to exceeding the goal (full circle).

The five potential alternatives were also evaluated for how well they incorporated top-ranked access points and path types, based on the community feedback described on pages 191–194 in this chapter.

Alignment D performed the lowest in response to community feedback as it had the fewest number of high prioritized access points and the most incised path type.

The top five potential alternatives have a number of key similarities. They have similar lengths (7.93 to 8.12 miles), number of crossings (5 to 7), and access points (10 to 12). All alternatives connect to key access points such as Los Angeles State Historic Park/Main Street, Mission Road/Cesar Chavez Avenue, Union Station, and Washington Boulevard. These key access points performed well with the goals, responded to the public input, and had no suitable alternatives.

The five screened alternatives feature a number of subtle but key differences. Each performs well with the goals, but in different ways and to different degrees. Each alternative has a unique combination of path types, crossings, and access points. Crossings occur in different locations in order to provide access to a unique combination of access points. Variation in access points occur in locations where several suitable alternatives exist, such as between 1st Street West and 1st Street East.

Each potential alternative also features future opportunities for path alignments and access points. Future opportunities go beyond the current budget of the project and provide design alternatives that could be added over time.

Linear alignments, path types, access points, and key benefits of the five alternatives are shown in Maps 25–29.

Table 9. Alternative Comparison Matrix

Alternative	A	B	C	D	E
Path Length	7.93 miles	8.02 miles	8.12 miles	7.96 miles	7.95 miles
Crossings	6	7	7	5	6
Access Points	10	12	11	10	10
Safety	●	●	●	●	●
Access	◐	●	◐	◑	◐
Mobility	◐	◐	●	◑	◐
Equity	●	◐	●	●	◑
User Experience	◐	●	◐	◑	◐
Health	●	●	●	◑	◑
Community Feedback	●	●	●	◑	●
Summary	●	●	●	◑	◐



Following the final screenings of the five potential alternatives, the three path alternatives that responded best to both the evaluation criteria and the community feedback on access points and path types were ultimately presented to the community for their feedback in May 2019. Based on the mostly positive response received, these three path alternatives were selected to move forward to environmental review.

The top three path alternatives — alternatives A, B, and C — provide the greatest community benefits, respond best to community preferences, and best meet the project goals. Chapter 10 dives deeper into each of the three top alternatives and explains the next steps for the project.

Map 25. Alignment A

Benefits of Alignment A

- **Equity:** path links communities with connections between Lincoln Heights, Boyle Heights, and Arts District.
- **Health:** potential for community gathering areas.

PATH LENGTH (MILES)	7.93
CROSSINGS	6
ACCESS POINTS	10
SAFETY	●
ACCESS	◐
MOBILITY	◐
EQUITY	●
USER EXPERIENCE	◐
HEALTH	●
COMMUNITY FEEDBACK	●



Legend

- West Bank Elevated
- West Bank Top-of-Bank
- West Bank Incised
- East Bank Elevated
- East Bank Top-of-Bank
- East Bank Incised
- Crossing
- Existing Path
- West Access Point
- East Access Point
- Existing Access Point

Future Opportunity

- Channel Bottom
- Access Point

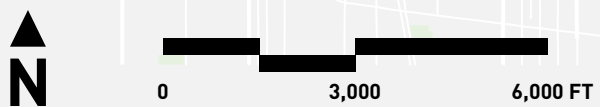

Map 26. Alignment B

Benefits of Alignment B

- **Access:** direct connections to services and job centers in Downtown Los Angeles, Little Tokyo, and Vernon.
- **User experience:** minimal grade change and unique vistas from elevated and top-of-bank paths.

PATH LENGTH (MILES)	8.02
CROSSINGS	7
ACCESS POINTS	12
SAFETY	●
ACCESS	●
MOBILITY	◐
EQUITY	◐
USER EXPERIENCE	●
HEALTH	●
COMMUNITY FEEDBACK	●



Legend

- West Bank Elevated
- West Bank Top-of-Bank
- West Bank Incised
- East Bank Elevated
- East Bank Top-of-Bank
- East Bank Incised
- Crossing
- Existing Path
- West Access Point
- East Access Point
- Existing Access Point
- Future Opportunity**
- Channel Bottom
- Access Point

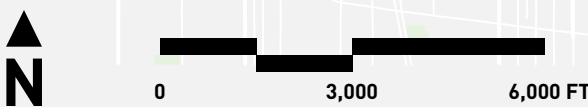

Map 27. Alignment C

Benefits of Alignment C

- **Equity:** path links communities with connections between Lincoln Heights, Boyle Heights, and Arts District.
- **Efficient and sustainable mobility:** Likely to remain open during flood events.

PATH LENGTH (MILES)	8.12
CROSSINGS	7
ACCESS POINTS	11
SAFETY	●
ACCESS	◐
MOBILITY	●
EQUITY	●
USER EXPERIENCE	◐
HEALTH	●
COMMUNITY FEEDBACK	●

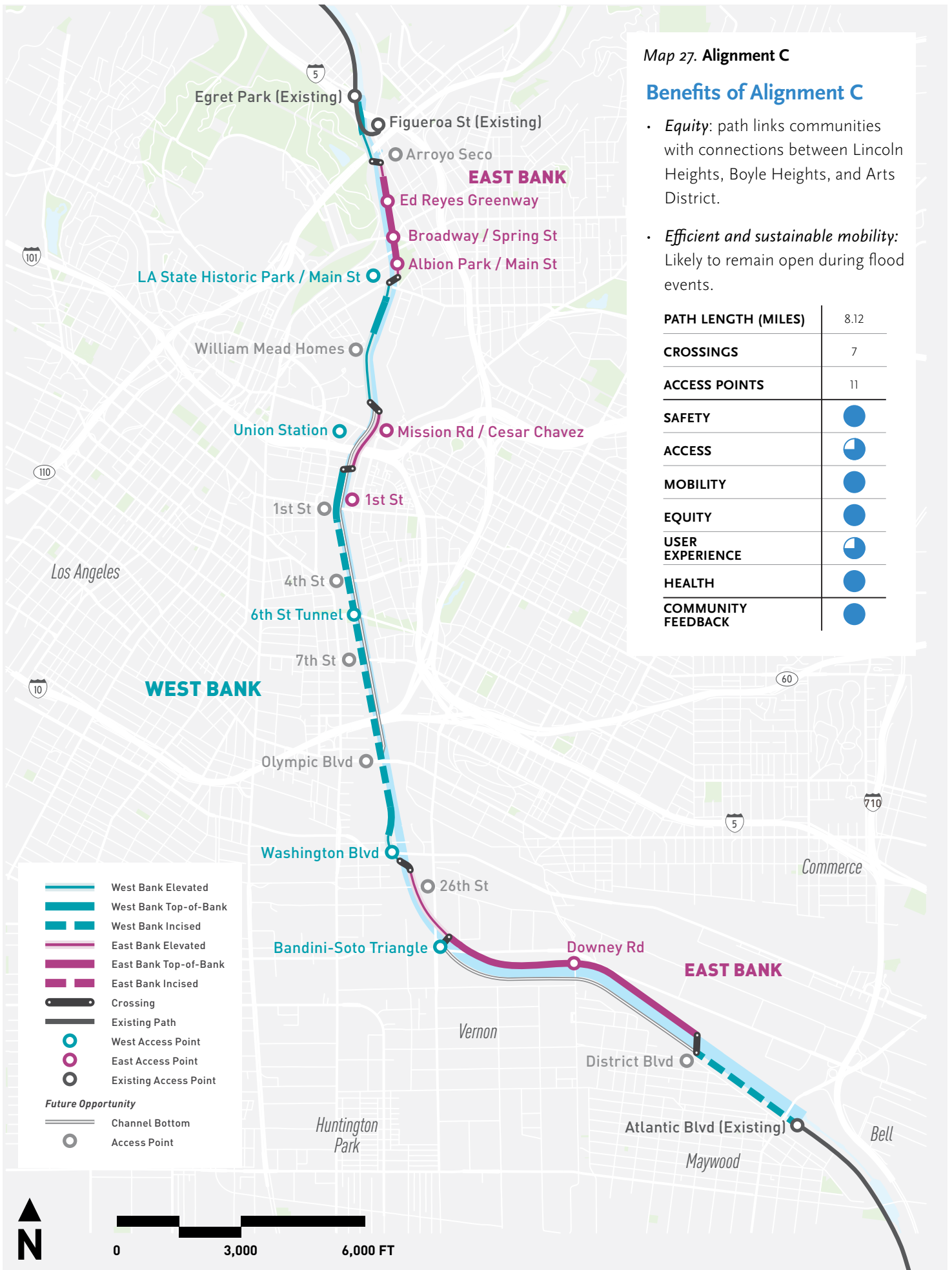

— West Bank Elevated
— West Bank Top-of-Bank
- - West Bank Incised
— East Bank Elevated
- - East Bank Top-of-Bank
- - East Bank Incised
— Crossing
— Existing Path
○ West Access Point
○ East Access Point
○ Existing Access Point
Future Opportunity
— Channel Bottom
○ Access Point

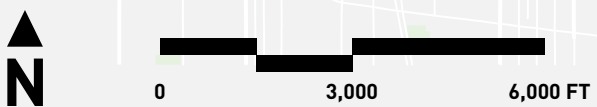

Map 28. Alignment D

Benefits of Alignment D

- **Equity:** several access points to Boyle Heights and William Mead Homes.
- **Efficient and sustainable mobility:** direct connections to the active transportation network and transit.

PATH LENGTH (MILES)	7.96
CROSSINGS	5
ACCESS POINTS	10
SAFETY	●
ACCESS	◐
MOBILITY	◐
EQUITY	●
USER EXPERIENCE	◐
HEALTH	◐
COMMUNITY FEEDBACK	◐



Legend

- West Bank Elevated
- West Bank Top-of-Bank
- West Bank Incised
- East Bank Elevated
- East Bank Top-of-Bank
- East Bank Incised
- Crossing
- Existing Path
- West Access Point
- East Access Point
- Existing Access Point

Future Opportunity

- Channel Bottom
- Access Point

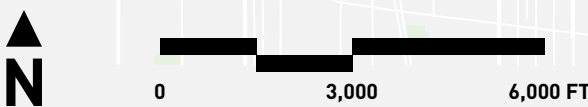

Map 29. Alignment E

Benefits of Alignment E

- *Access:* direct connections between east side neighborhoods and west side jobs and destinations.
- *Efficient and sustainable mobility:* direct connections to the active transportation network and transit.

PATH LENGTH (MILES)	7.95
CROSSINGS	6
ACCESS POINTS	10
SAFETY	●
ACCESS	◐
MOBILITY	◐
EQUITY	◐
USER EXPERIENCE	◐
HEALTH	◐
COMMUNITY FEEDBACK	●



— West Bank Elevated
- - - West Bank Top-of-Bank
· · · West Bank Incised
— East Bank Elevated
- - - East Bank Top-of-Bank
· · · East Bank Incised
 Crossing
 Existing Path
○ West Access Point
○ East Access Point
○ Existing Access Point
Future Opportunity
 Channel Bottom
○ Access Point

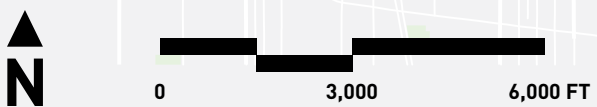

This page intentionally left blank



10

PATH ALTERNATIVES

Why is this important?

The alternative evaluation process resulted in three top performing alternatives that best meet the project goals and community needs.



How does it apply to the LA River Path?

Chapter 10 describes the similarities and differences between alternatives A, B and C, summarizes community feedback on the three alternatives, and explains the next steps for the project.

PATH ALTERNATIVES

Alternatives A, B, and C are recommended to be studied through the environmental review process over the next several years, to ultimately define a Locally Preferred Alternative (LPA) for final design. All three alternatives meet the project goals and within 3 miles will serve 933,574 residents and provide access to 629,215 jobs.

Alternatives Similarities

The three alternatives feature a number of design similarities. First, they all start and end on the west bank to connect to the existing paths along the Los Angeles River.

Second, the alternatives use a combination of three path types (elevated, top-of-bank/cantilevered, and incised) and cross the river to utilize both sides of the river bank.

They also feature the opportunity for a future bottom-of-channel loop between Union Station and Olympic Boulevard and in Vernon. In one highly constrained area, Redondo Junction, all alternatives begin on the west bank and transition to the east bank to avoid impacts to existing infrastructure, to achieve acceptable path grades, and to take advantage of public right-of-way opportunities.

Finally, Alternatives A, B, and C feature several shared access points as illustrated in Table 10, including access to destinations that were rated highly by the community as listed below:

- **Los Angeles State Historic Park/Main Street Access:** Provides access to regional parks and serves as the gateway to Chinatown.

Community Benefits

933,000+ residents served 
access to **629,000+** jobs 

Based on a three mile radius of proposed access points. These are representative numbers for all three path alternatives.

- **Albion Park/Main Street Access:** Provides access to a local recreation center and serves as the gateway to Lincoln Heights.
- **Mission Road/Cesar Chavez Avenue Access:** Serves major employment connections, both Lincoln Heights and Boyle Heights, and has potential for a community gathering space.
- **Union Station Access:** Provides the most access to employment and transit connections of any access point.
- **Washington Boulevard Access:** Breaks up a long stretch of the path without access and serves connections to the Blue Line.
- **Bandini-Soto Triangle Access:** Connects to a key commercial hub and serves major employers in Vernon.
- **Downey Road East Access:** Breaks up a long stretch of the path without access and serves major employers in Vernon.
- **Olympic Boulevard East:** All three alternatives feature a future access point at Olympic Boulevard, which was added in response to community feedback received during the May 2019 community open houses to provide more future east side connections to the river.

Table 10. Proposed and Future Access Points for Each Alternative and the Neighborhoods They Serve

ACCESS POINT	ALTERNATIVE			NEIGHBORHOOD									
	A	B	C	Elysian Valley	Cypress Park	Lincoln Heights	Chinatown	Civic Center	Arts District	Boyle Heights	Vernon	Maywood	
Egret Park Existing	●	●	●										
Figueroa Street Existing	●	●	●										
Arroyo Seco	●	●	●										
Ed Reyes Greenway	●	●	●										
Broadway / Spring Street	●		●										
Los Angeles State Historic Park / Main Street	●	●	●										
Albion Park / Main Street	●	●	●										
William Mead Homes			●										
Piggyback Yard	●	●	●										
Mission Road / Cesar Chavez Avenue	●	●	●										
Union Station	●	●	●										
1st Street West		●	●										
1st Street East	●		●										
4th Street West	●	●	●										
6th Street Tunnel	●	●	●										
7th Street West	●		●										
7th Street East		●											
Olympic Boulevard West	●	●	●										
Washington Boulevard	●	●	●										
26th Street	●	●	●										
Bandini-Soto Triangle	●	●	●										
Downey Road East	●	●	●										
District Boulevard			●										
Atlantic Boulevard East	●	●											
Atlantic Boulevard Existing	●	●	●										

Unique Characteristics

The three alternatives vary in their combination of path types and access points. The path types seen in the alternatives respond to site conditions in different ways. For example, Main Street is an at-grade bridge. Two alternatives (B and C) cross over Main Street while one alternative (A) passes under Main Street. In addition, the way in which alternatives connect to key destinations results in different user experiences. An example is connecting to 1st Street. Two alternatives connect to 1st Street on the east bank (A and C) and one alternative (B) connects on the west bank.

Cost Estimates

The following pages describe key features, differentiators, path type details, and cost estimates for the three alternatives.

An upper-bound cost and lower-bound cost was calculated for each alignment.

- Upper Bound: Accounts for “world-class” features and amenities that require custom designs, non-standard features, and specialized construction methods. Width varies from 14 feet to 20 feet along the path based on bicycle and pedestrian demand projections.
- Lower Bound: Accounts for standard width and features. Constant 14-foot width.

Hard Costs include material, equipment, labor, and property acquisition.

Soft Costs include consultant contracts, project administration, and construction management. All costs are shown in 2019 dollars.

The majority of the cost for building the LA River Path is in the construction of the linear path alignment, accounting for 70% to 74% of the overall cost. For the three alternatives, the linear path alignment varies from 14 to 20-feet wide and consists of a combination of top-of-bank, elevated and incised path types.

The second largest cost is construction related to accessing the path from the surrounding neighborhoods and streets. Between 13% and 22% of the overall cost is associated with access points, overcrossings, and ramps that connect the street network to the path within the channel corridor.

Finally, river crossings account for 8% to 13% of the overall project cost. Crossings are used to navigate around existing infrastructure and hydraulic constraints, best utilize existing right-of-way, and connect to community-prioritized access points.

ALTERNATIVE A

Key Features

Alternative A has the most consistent path type of the three alternatives, with the fewest river crossings and fewest transitions between path types. Key features include:

- **Future Loop:** Future opportunity to expand access with a northern loop between Figueroa Street and Albion Park.
- **1st Street East:** Path provides direct access to Mission Road and 1st Street near Mendez High School.
- **Downtown Crossing:** Path crosses the river near 4th Street, providing future access opportunities on both sides of the river.
- **7th Street Access:** Top-of-bank path between 4th Street and Olympic Boulevard enables Arts District access at 7th Street.
- **Future Bottom-of-Channel Path:** Future opportunities between Union Station and Olympic Boulevard and between Bandini-Soto and Atlantic Boulevard.

RESPONSE TO PUBLIC INPUT

- Alternative A is 48% top-of-bank path, the most desired path type.
- 7th Street was the most desired access point between 4th Street and Olympic Boulevard.
- Future access opportunities at 4th Street bridge, Arroyo Seco, and 6th Street Tunnel, all top rated access points.

Path Statistics

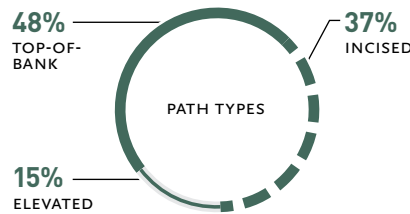

7.93
MILES
6
CROSSINGS
10
ACCESS POINTS
5 EAST BANK
5 WEST BANK

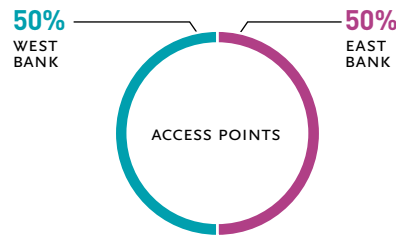

Transit Access

Which Metro Stations are served?

- Union Station ●●●●
- Chinatown ●
- Pico / Aliso ●
- Washington Bl ●

Cost Estimate

What is the estimated cost for this alignment and how is it distributed?

Hard costs	\$216M - \$305M
Soft costs	\$83M - \$98M
Project Contingency	\$30M - \$40M
Total Cost	\$329M - \$443M

*based on 2019 values.

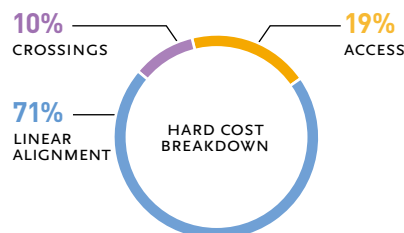

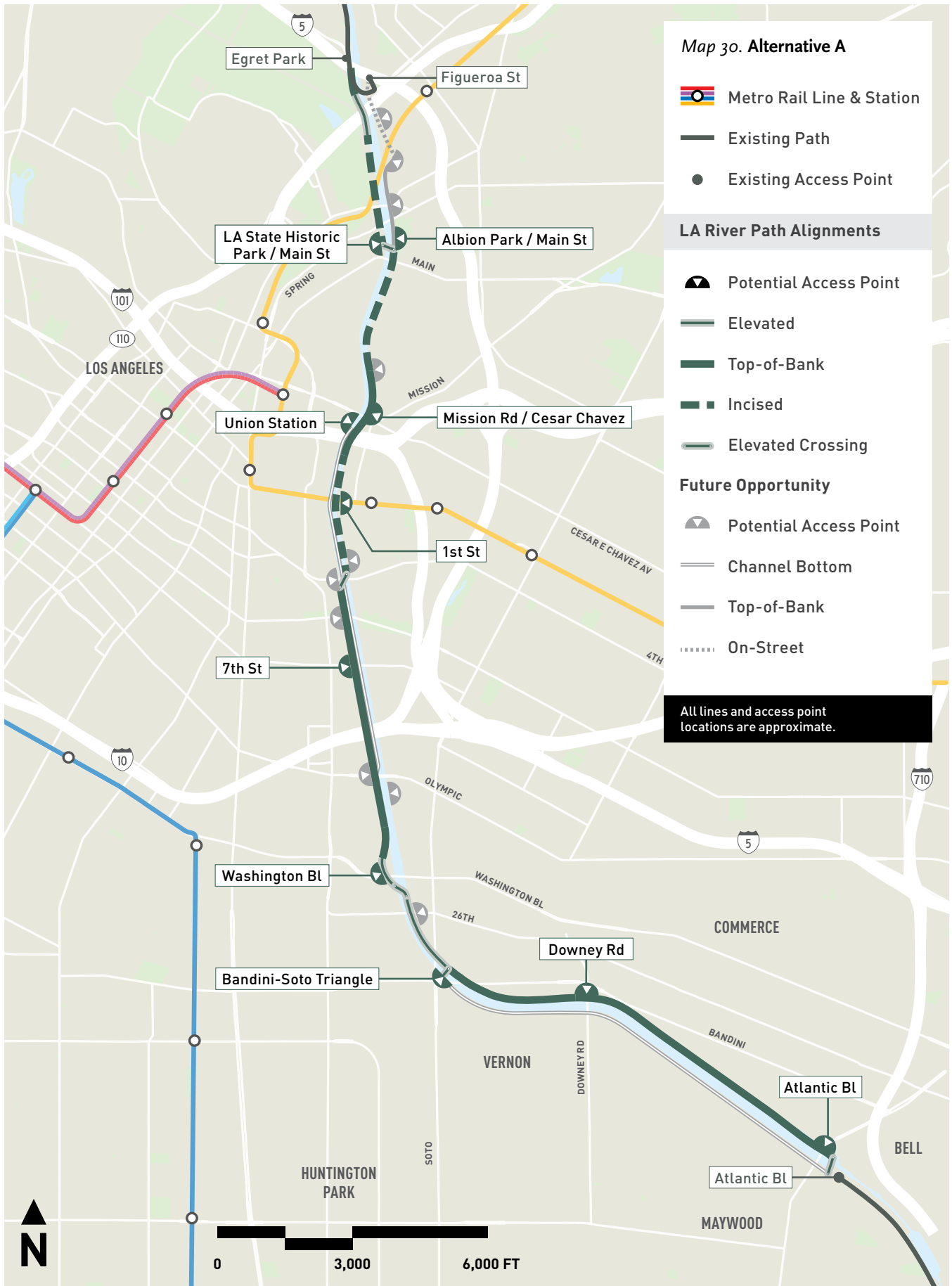

ALTERNATIVE B

Key Features

Alternative B has the most access points of the three alternatives, with the most connections to parks and to downtown Los Angeles. Key features include:

- **Parks Confluence:** Path provides access to Albion Park, Los Angeles State Historic Park, and Ed Reyes Greenway.
- **Union Station:** Path provides a direct connection between Cesar Chavez Avenue and Union Station.
- **1st Street West:** Path provides Little Tokyo access at 1st Street bridge.
- **7th Street/6th Street Park:** Path provides a crossing and access point at 7th Street / 6th Street Park.
- **Future Bottom-of-Channel Path:** Future opportunities between Union Station and Olympic Boulevard and between Bandini-Soto and Atlantic Boulevard.

RESPONSE TO PUBLIC INPUT

- From the northern terminus through 1st Street Alternative B is elevated and top-of-bank, the top two desired path types.
- Mission Road/Cesar Chavez Avenue and Union Station were the top rated access points for people who want to commute.
- Future access opportunities at 4th Street bridge and Arroyo Seco, both top rated access points.

Path Statistics

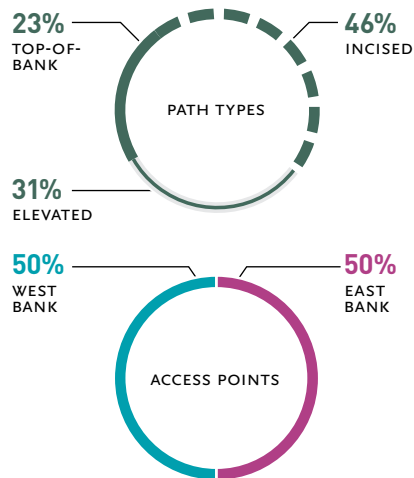

8.02 MILES
7 CROSSINGS
12 ACCESS POINTS
6 EAST BANK
6 WEST BANK

Transit Access

Which Metro Stations are served?

- **Union Station** ●●●●
- **Chinatown** ●
- **Lincoln / Cypress** ●
- **Little Tokyo / Arts District** ●
- **Washington Bl** ●

Cost Estimate

What is the estimated cost for this alignment and how is it distributed?

Hard costs	\$265M - \$366M
Soft costs	\$92M - \$109M
Project Contingency	\$36M - \$48M
Total Cost	\$393M - \$523M

*based on 2019 values.

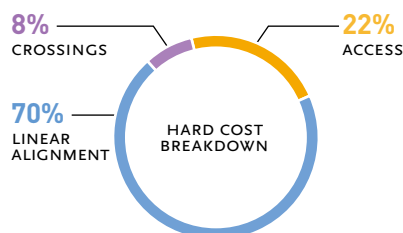

Map 31. Alternative B

 Metro Rail Line & Station

 Existing Path

 Existing Access Point

LA River Path Alignments

 Potential Access Point

 Elevated

 Top-of-Bank

 Incised

 Elevated Crossing

Future Opportunity

 Potential Access Point

 Channel Bottom

 Top-of-Bank

 On-Street

All lines and access point locations are approximate.

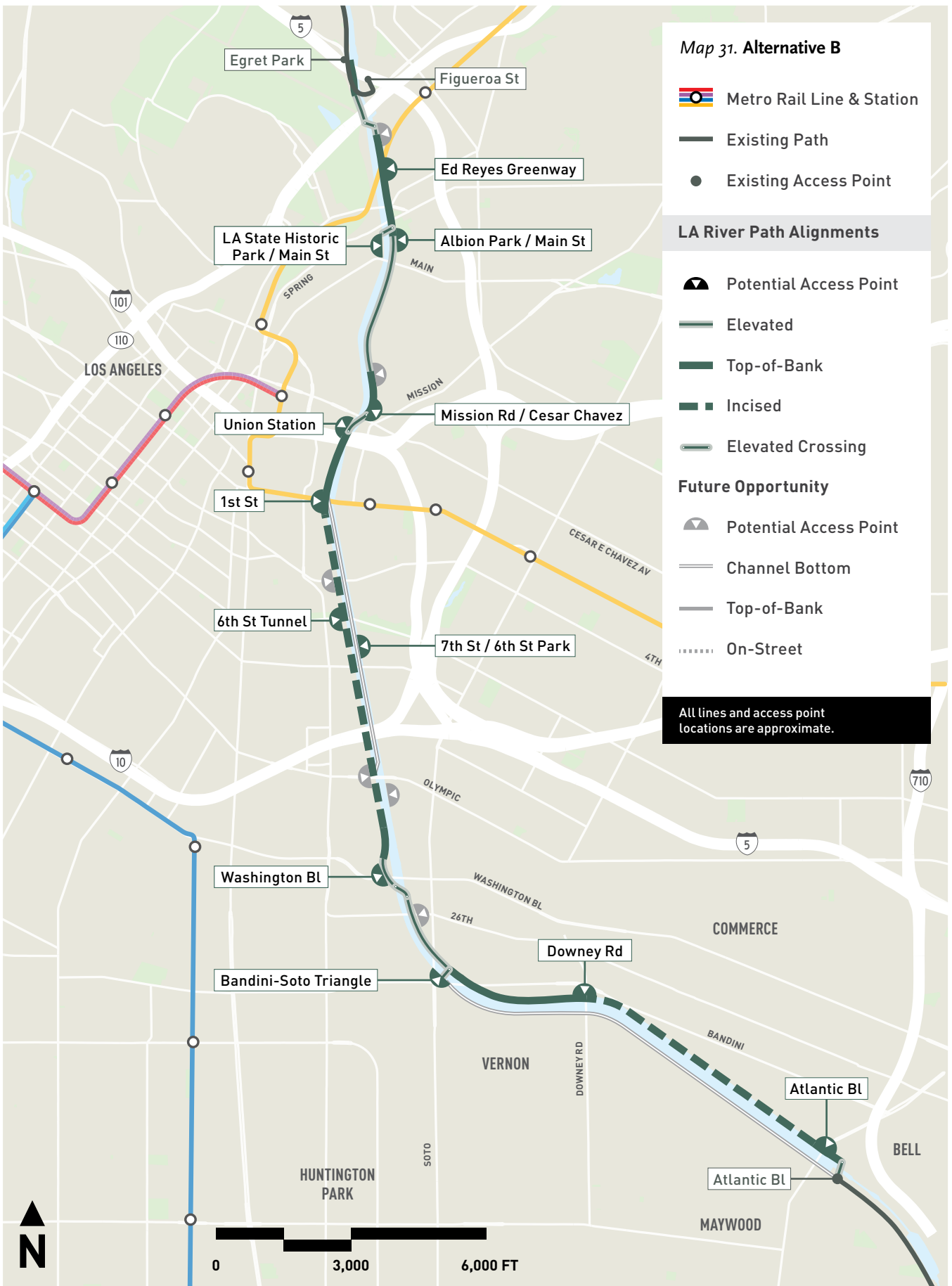

ALTERNATIVE C

Key Features

Alternative C has the most direct connections between access points and between the east and west side of the river. Key features include:

- **Lincoln Heights Connections:** Path passes through Lincoln Heights providing access to Ed Reyes Greenway, Broadway / Spring Street, and Albion Park.
- **Union Station Confluence:** Elevated path provides direct connections between 1st Street East, Union Station, and Mission Road / Cesar Chavez Avenue.
- **6th Street Tunnel:** Path provides Arts District access at the 6th Street Tunnel.
- **District Crossing:** Path crosses the river between Downey Road and Atlantic Boulevard to provide a future access opportunity at District Boulevard.
- **Future Bottom-of-Channel Path:** Future opportunities between Union Station and Olympic Boulevard and between Bandini-Soto and Atlantic Boulevard.

RESPONSE TO PUBLIC INPUT

- Alternative C is 59% of combined top-of-bank and elevated path, the top two desired path types.
- 1st Street west was a top rated access point.
- Future access opportunities at Arroyo Seco and William Mead Homes, two top rated access points in the north.

Path Statistics

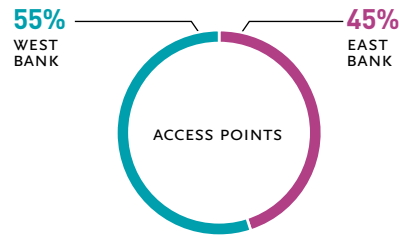
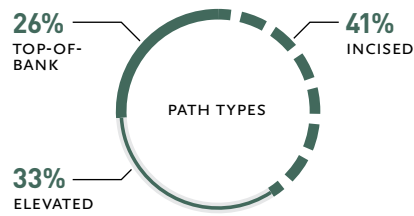

8.12
MILES

7
CROSSINGS

11
ACCESS POINTS
6 EAST BANK
5 WEST BANK

Transit Access

Which Metro Stations are served?

- **Union Station** ●●●●
- **Chinatown** ●
- **Lincoln / Cypress** ●
- **Pico / Aliso** ●
- **Washington Bl** ●

Cost Estimate

What is the estimated cost for this alignment and how is it distributed?

Hard costs	\$218M - \$307M
Soft costs	\$84M - \$99M
Project Contingency	\$30M - \$40M
Total Cost	\$332M - \$446M

*based on 2019 values.

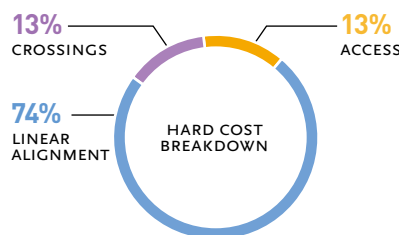

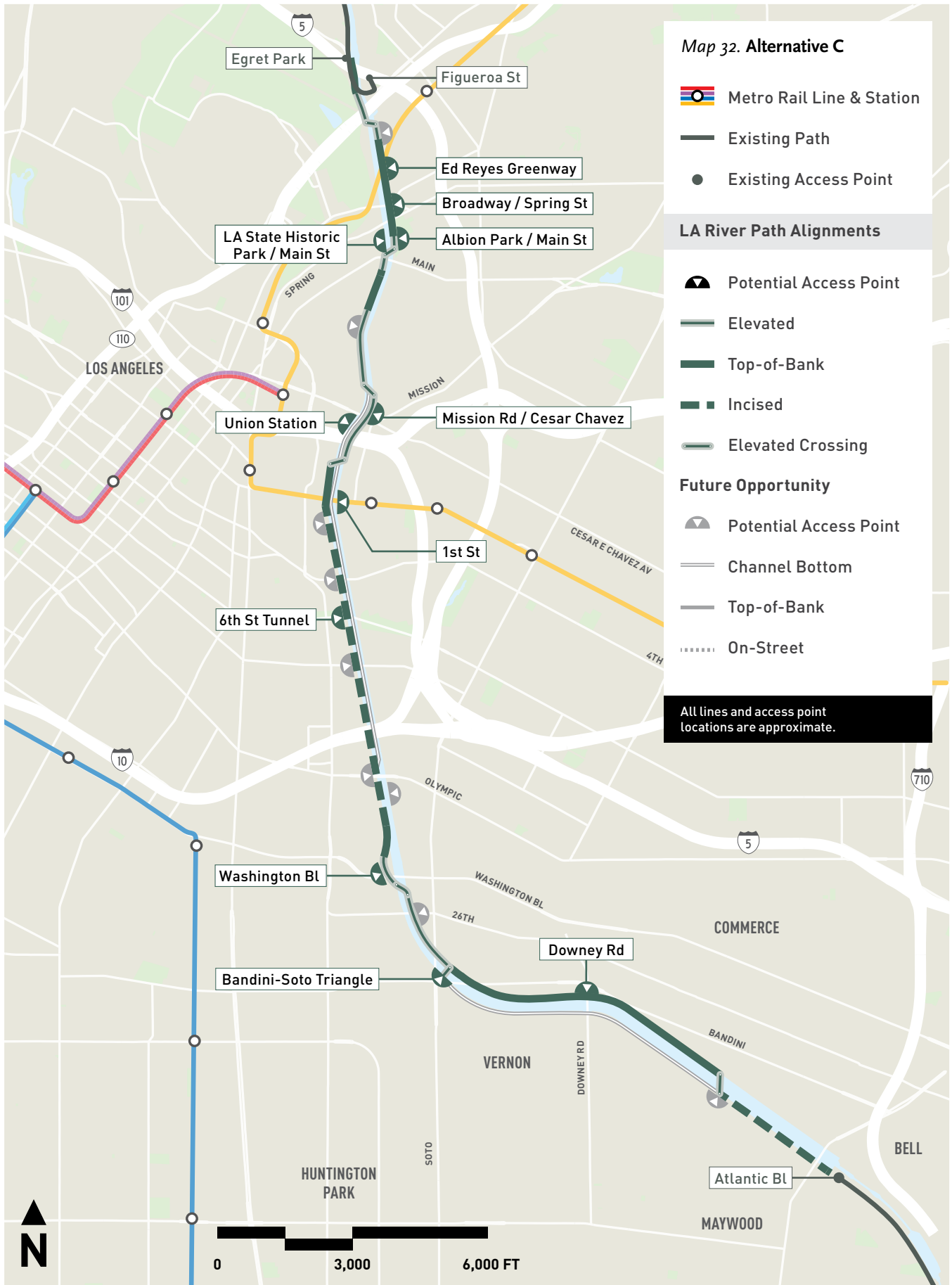



COMMUNITY FEEDBACK ON PATH ALTERNATIVES

During the third round of community engagement events in early May 2019, the project team presented the three top-performing alternatives to the public to ensure previous feedback had been captured and the alternatives were not missing any pertinent features. Community members were asked to provide their comments during one stakeholder roundtable, three community open houses, one “Coffee with the Principal” meeting, and numerous stakeholder briefings. Overall, most community members at the events were supportive of the three alternatives, noting that the alternatives captured the most important access points.

A couple of emerging themes were heard during the outreach events. First, the project team heard from numerous community members that a reliable path that closes the gap and would be open the most days of the year is very important. Second, some on-street connections to access points on the east side of the river can be difficult. As a result of hearing this feedback, the project team added a future access point at Olympic Boulevard to all three alternatives in order to improve future east side connections to the river.

Finally, community members expressed their desire to have user separated facilities when possible, noting that the existing LA River Path is narrow at points and often has user conflicts, such as in Elysian Valley. The project team will continue to take this into consideration when conducting a full LOC analysis during the environmental phase.

In addition to the community meetings, a video was produced for community members who were unable to attend the meetings in-person, allowing them to keep up to date on the project’s goals, priorities, and recommended path alternatives. The video was promoted through Facebook and Metro’s project website, as well as through email to those on Metro’s project distribution list.

The majority of community members were supportive of the three alternatives, however some expressed interest in including bottom-of-channel as a core path alternative, rather than a future loop option. The minority of community members who supported a bottom-of-channel path did so primarily because of the perception that it would be the lowest cost option and remove barriers to accessing the river.

Figure 53. Examples of Community Comments on Proposed Alternatives for Further Study, May 2019

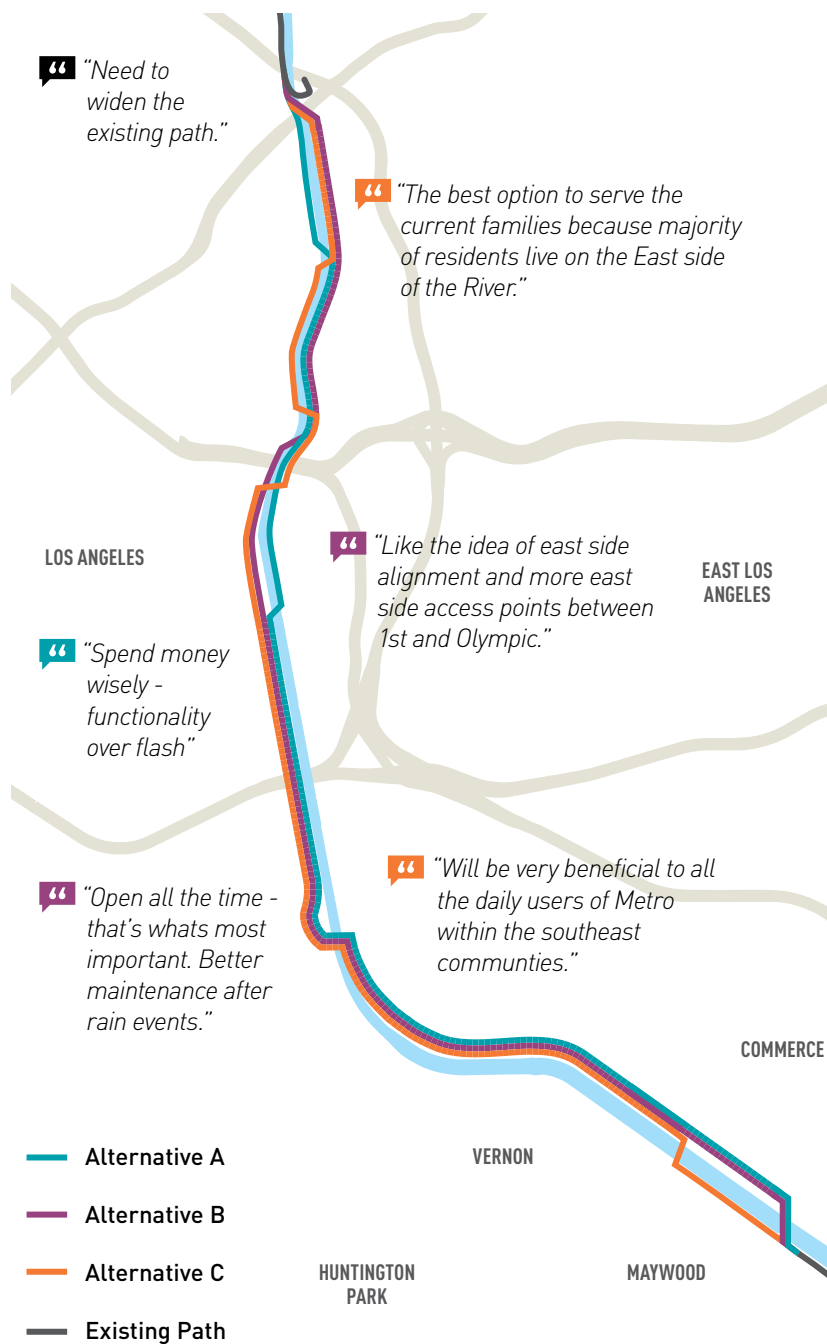

NEXT STEPS

Environmental Review, Conceptual Engineering, and Permitting

This report identifies three alternatives to be studied during the environmental review process. To construct the path, Metro is required to complete a state environmental review (CEQA), which will include evaluation of up to three path alternatives. Federal environmental review (NEPA) will also be required because of potential impacts to the Los Angeles River under the jurisdiction of the USACE, a federal agency.

The environmental review phase has several steps and is planned to occur over the next several years (Figure 54). It is anticipated to begin in fall of 2019 with a public input period called the Scoping Period.

The environmental review will include in-depth study of the three alternatives' potential impacts and benefits on a range of topics, including but not limited to socioeconomics, historic resources, and traffic.

The alternatives for environmental review will be studied and evaluated based on conceptual-level engineering and related technical and environmental information, along with public and stakeholder input (see Table 11). This technical analysis of

each alternative will focus on considering potential impacts, and will involve the public and stakeholders in the evaluation. The purpose of the final screening step is to provide sufficient information needed to identify a locally preferred alternative (LPA).

Following the Final Environmental Impact Report (FEIR), the project will seek a series of approvals from various federal, state, and local agencies as part of the permitting process.

The alternatives and options will continue to be modified and narrowed based on ongoing discussions with project partners, public input, and to ensure that they meet the project's Purpose and Need which will be finalized during the environmental process.

Design of the path including aesthetics and path amenities will continue into the next phase of the project and will be included in ongoing community engagement. Metro will work with stakeholders and community members to ensure artwork opportunities and artwork designs are integrated into the project. With a focus on creating a world-class user experience, design themes and elements will be incorporated during environmental review and further design.

Figure 54. Proposed Environmental Review Process and Timeline

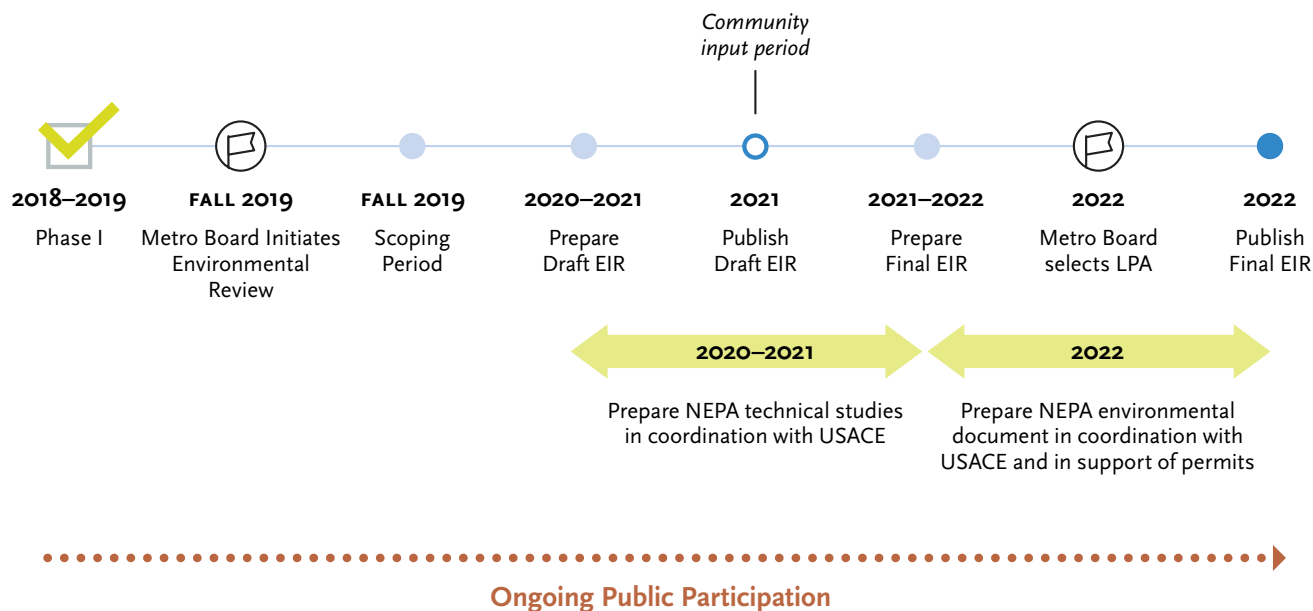

Table 11. Design and Environmental Tasks

DESIGN	ENVIRONMENTAL	OPERATIONAL	CUMULATIVE/CONSTRUCTION
Alignment plan and profile Access point design Landscape Wayfinding Lighting Structural design Right-of-way Utility investigations Geotech investigations Cross sections Construction scenarios	PHYSICAL & SOCIOECONOMIC Land use/planning Population/housing Growth inducing Aesthetics and visuals Public services (safety/security) Environmental justice* Displacement* Economic and fiscal* CULTURAL/COMMUNITY RESOURCES Tribal Parklands Cultural (historic, archaeological, paleological) Section 106/SHPO*	NATURAL RESOURCES Transportation Air quality/GHG Climate change Energy Noise and vibration Water/hydrology Biological resources Wildfire Geotech and soils Hazardous materials	

*NEPA-only environmental tasks

PHOTO CREDITS

#	Page	Source	#	Page	Source
01	EX-2	Alta Planning + Design	36	20	Alta Planning + Design
02	EX-10	CH2M	37	20	Metro
03	EX-10	Alta Planning + Design	38	20	Metro
04	EX-10	Alta Planning + Design	39	25	Alta Planning + Design
05	EX-10	Alta Planning + Design	40	25	Alta Planning + Design
06	EX-16	Metro	41	25	Alta Planning + Design
07	EX-16	Alta Planning + Design	42	25	Alta Planning + Design
08	EX-16	Metro	43	32	Alta Planning + Design
09	EX-16	Metro	44	36	Alta Planning + Design
10	EX-16	Alta Planning + Design	45	37	Alta Planning + Design
11	EX-16	Metro	46	38	Alta Planning + Design
12	EX-16	Alta Planning + Design	47	42	Alta Planning + Design
13	EX-22	Metro	48	43	Alta Planning + Design
14	EX-22	Alta Planning + Design	49	46	Alta Planning + Design
15	EX-22	Metro	50	68	Alta Planning + Design
16	EX-22	Metro	51	73	Alta Planning + Design
17	EX-22	Metro	52	73	Alta Planning + Design
18	EX-33	ArchDaily	53	73	Alta Planning + Design
19	EX-33	Tim Street Porter	54	77	Alta Planning + Design
20	EX-33	Jay Janner / AMERICAN-STATESMAN	55	77	Alta Planning + Design
21	EX-33	Pernille Enoch	56	79	Alta Planning + Design
22	EX-33	RS Architektura Kraj brazu	57	79	Alta Planning + Design
23	EX-33	Ten Eyck Landscape Architects	58	79	Alta Planning + Design
24	EX-33	Refik Anadol + Peggy Weil	59	86	Alta Planning + Design
25	2	Alta Planning + Design	60	86	Alta Planning + Design
26	10	Alta Planning + Design	61	86	Alta Planning + Design
27	10	Alta Planning + Design	62	86	Alta Planning + Design
28	10	Alta Planning + Design	63	86	Alta Planning + Design
29	12	Alta Planning + Design	64	88	Alta Planning + Design
30	14	Alta Planning + Design	65	90	Alta Planning + Design
31	14	California Historical Society	66	92	Alta Planning + Design
32	14	California Historical Society	67	128	Alta Planning + Design
33	14	Los Angeles Public Library	68	128	LAMM Architecture
34	14	US Army Corps of Engineers	69	128	Alta Planning + Design
35	14	Pasadena Museum of History	70	129	Alta Planning + Design
		Los Angeles Public Library	71	129	Alta Planning + Design

#	Page	Source
72	129	Alta Planning + Design
73	129	Alta Planning + Design
74	129	Alta Planning + Design
75	140	Sandis
76	140	Jacobs
77	140	Jacobs
78	144	Tim Toomy
79	144	Alta Planning + Design
80	144	Maurits Lopes Cardozo with ipv Delft
81	144	Maurits Lopes Cardozo with ipv Delft
82	144	CADW 2016
83	152	Alta Planning + Design
84	154	Kathleen McLaughlin
85	154	Uncle Hu Lai Hulai
86	154	David Boureau
87	154	Jack Finnigan
88	154	Maurice Tabard
89	154	Robert Lemermeyer
90	154	Dissing + Weitling
91	154	Chris Keulen/National Geographic
92	156	Metro
93	156	Metro
94	156	Debra Scacco
95	158	Dissing + Weitling
96	158	ipv Delft
97	158	Refik Anadol & Peggy Weil
98	158	Studio Roosegaarde
99	159	Alta Planning + Design
100	159	Alta Planning + Design
101	159	Alta Planning + Design
102	159	Alta Planning + Design
103	159	Alta Planning + Design
104	161	RS AK (RS Architektura Krajobrazu)

105	161	Pernille Enoch
106	161	Jamie Fogle
107	161	UM Warszawa
108	161	RS Architektura Krajobrazu
109	161	LADOT
110	164	Dillon Diers / The Office of James Burnett
111	164	Buster Simpson
112	164	Ten Eyck Landscape Architects
113	166	Alta Planning + Design
114	180	Alta Planning + Design
115	189	Alta Planning + Design
116	189	Alta Planning + Design
117	189	Alta Planning + Design
118	189	Alta Planning + Design
119	222	Alta Planning + Design

